

# DHI Eutrophication Model 1 – Including Sediment and Benthic Vegetation

MIKE ECO Lab Template

Scientific Description



**DHI headquarters**

Agern Allé 5  
DK-2970 Hørsholm  
Denmark

+45 4516 9200 Telephone

[mike@dhigroup.com](mailto:mike@dhigroup.com)

[www.mikepoweredbydhi.com](http://www.mikepoweredbydhi.com)

Company Registration No.: DK36466871

# CONTENTS

## DHI Eutrophication Model 1 – Including Sediment and Benthic Vegetation MIKE ECO Lab Template Scientific Description

<b>1</b>	<b>Introduction</b> .....	<b>1</b>
<b>2</b>	<b>Applications</b> .....	<b>3</b>
<b>3</b>	<b>Mathematical Formulations</b> .....	<b>5</b>
3.1	Phytoplankton Carbon (PC).....	6
3.2	Phytoplankton Nitrogen (PN).....	10
3.3	Phytoplankton Phosphorus (PP).....	10
3.4	Chlorophyll-a (CH) .....	11
3.5	Zooplankton (ZC).....	12
3.6	Detritus .....	14
3.7	Detritus Carbon (DC).....	15
3.8	Detritus Nitrogen (DN).....	16
3.9	Detritus Phosphorus (DP).....	17
3.10	Inorganic Nitrogen (IN).....	18
3.11	Inorganic Phosphorus (IP).....	20
3.12	Oxygen (DO).....	21
3.13	Benthic Vegetation (BC).....	23
<b>4</b>	<b>Extended Description of Macroalgae and Rooted Vegetation</b> .....	<b>25</b>
4.1	Macroalgae .....	25
4.2	Rooted Vegetation .....	25
<b>5</b>	<b>Extended Sediment Description</b> .....	<b>29</b>
5.1	N and P Cycle in the Sediment Module.....	29
5.2	Nitrogen Processes .....	31
5.3	Phosphorus Processes .....	36
5.4	Differential Equations .....	38
5.5	Parameters .....	39
<b>6</b>	<b>Future Developments</b> .....	<b>41</b>
<b>7</b>	<b>Solution Technique</b> .....	<b>43</b>
<b>8</b>	<b>Data Requirements</b> .....	<b>45</b>
<b>9</b>	<b>List of References</b> .....	<b>47</b>



## 1 Introduction

MIKE ECO Lab is a numerical lab for Ecological Modelling. It is a generic and open tool for customising aquatic ecosystem models to describe water quality and eutrophication amongst others. DHI's expertise and knowhow concerning ecological modelling has been collected in predefined ecosystem descriptions (MIKE ECO Lab templates) to be loaded and used in MIKE ECO Lab. So the MIKE ECO Lab templates describe physical, chemical and biological processes related to environmental problems and water pollution. The following is a description of the DHI Eutrophication Model 1 including an extended description of sediment and benthic vegetation.

The template is used in investigations of eutrophication effects and as an instrument in environmental impact assessments. The eutrophication modelling can be applied in environmental impact assessments considering:

- Pollution sources such as domestic and industrial sewage and agricultural run-off
- Cooling water outlets from power plants resulting in excess temperatures
- Physical conditions such as sediment loads and change in bed topography affecting especially the benthic vegetation.

The aim of using eutrophication modelling as an instrument in environmental impact assessment studies is to obtain, most efficiently in relation to economy and technology, the optimal solution with regards to ecology and the human environment.

The Eutrophication Model 1 describes nutrient cycling, phytoplankton and zooplankton growth, growth and distribution of rooted vegetation and macroalgae in addition to simulating oxygen conditions.

The model results describe the concentrations of phytoplankton, chlorophyll-a, zooplankton, organic matter (detritus), organic and inorganic nutrients, oxygen and the area-based biomass of benthic vegetation over time. In addition, a number of derived variables are stored: primary production, total nitrogen and phosphorus concentrations, sediment oxygen demand and secchi disc depth.

The Eutrophication Model 1 is integrated with the advection-dispersion module which describes the physical transport processes at each grid-point covering the area of interest. Other data required are concentrations at model boundaries, flow and concentrations from pollution sources, water temperature and irradiance etc.



## 2 Applications

The DHI Eutrophication Model 1 template can be applied in a range of environmental investigations:

- Studies where the effects of alternative nutrient loading scenarios are compared and/or different waste water treatment strategies are evaluated
- Studies of oxygen depletion
- Studies of the effects of the discharge of cooling water
- Comparisons of the environmental consequences of different construction concepts for harbours, bridges, etc.
- Evaluation of the environmental consequences of developing new urban and industrial areas.





### 3 Mathematical Formulations

The Eutrophication Model 1 is coupled to the advection modules of DHI hydraulic engines in order to simulate the simultaneous processes of transport, dispersion and biological/biochemical processes. The eutrophication model 1 incl. sediment and benthic vegetation results in a system of 25 differential equations describing the variations for 12 standard state variables and the extended description of macroalgae and rooted vegetation includes additional 4 state variables and the extended description of the sediment includes additional 9 state variables. The first 11 state variables are found in the pelagic system and are so-called advective state variables. The additional state variables belong to the benthic system. The benthic vegetation is attached to the sea bed, stones or the like. It is, therefore, not subject to transport by water movements or to dispersion. The sediment state variables are not subject to transport either.

The standard 12 state variables of the Eutrophication Model 1 are:

- Phytoplankton carbon (PC) (gC/m<sup>3</sup>)
- Phytoplankton nitrogen (PN) (gN/m<sup>3</sup>)
- Phytoplankton phosphorus (PP) (gP/m<sup>3</sup>)
- Chlorophyll-a (CH) (g/m<sup>3</sup>)
- Zooplankton (ZC) (gC/m<sup>3</sup>)
- Detritus carbon (DC) (gC/m<sup>3</sup>)
- Detritus nitrogen (DN) (gN/m<sup>3</sup>)
- Detritus phosphorus (DP) (gP/m<sup>3</sup>)
- Inorganic nitrogen (IN) (gN/m<sup>3</sup>)
- Inorganic phosphorus (IP) (gP/m<sup>3</sup>)
- Dissolved oxygen (DO) (g/m<sup>3</sup>)
- Benthic vegetation carbon (BC) (gC/m<sup>2</sup>)

The extended description of the benthic system (macroalgae and rooted vegetation) includes 4 more state variables:

- Benthic vegetation nitrogen (BN) (gN/m<sup>2</sup>)
- Benthic vegetation phosphorus (BP) (gP/m<sup>2</sup>)
- Eelgrass carbon (EC) (gC/m<sup>2</sup>)
- Eelgrass shoot numbers pr m<sup>2</sup> (No/m<sup>2</sup>)

The extended description of the sediment includes the 9 state variables:

- KDOX, depth of NO<sub>3</sub> penetration in sediment (m)
- SIP, Sediment phosphate in pore water (gP/m<sup>3</sup>)
- SPIM, Sediment P, immobile fraction (gP/m<sup>2</sup>)
- FESP, Sediment iron absorbed P (gP/m<sup>2</sup>)
- SOP, Sediment organic P (gP/m<sup>2</sup>)
- SON, Sediment organic NN (gN/m<sup>2</sup>)
- SNH, Sediment ammonia NH<sub>4</sub>-N in pore water (gN/m<sup>3</sup>)
- SNO<sub>3</sub>, NO<sub>3</sub>-N in Surface sediment pore water (gN/m<sup>3</sup>)
- SNIM, Sediment N, immobile fraction (gN/m<sup>2</sup>)

The processes and transfer of carbon, nitrogen and phosphorus in the Eutrophication model system is illustrated in Figure 3.1. Also included in the model is an oxygen balance.

The processes describing the variations of the components in time and space are dependent on external factors such as the salinity, water temperature, the light influx, and the discharges.

The salinity and water temperature can be results of MIKE 21/3 AD simulations or be user specified values. The first possibility is especially relevant for cooling water investigations whereas the latter possibility often is used in areas where only natural variations in temperature are seen.

The mathematical formulations of the biological and chemical processes and transformations for each state variable are described one by one below. The differential equations are 1st order, ordinary and coupled.

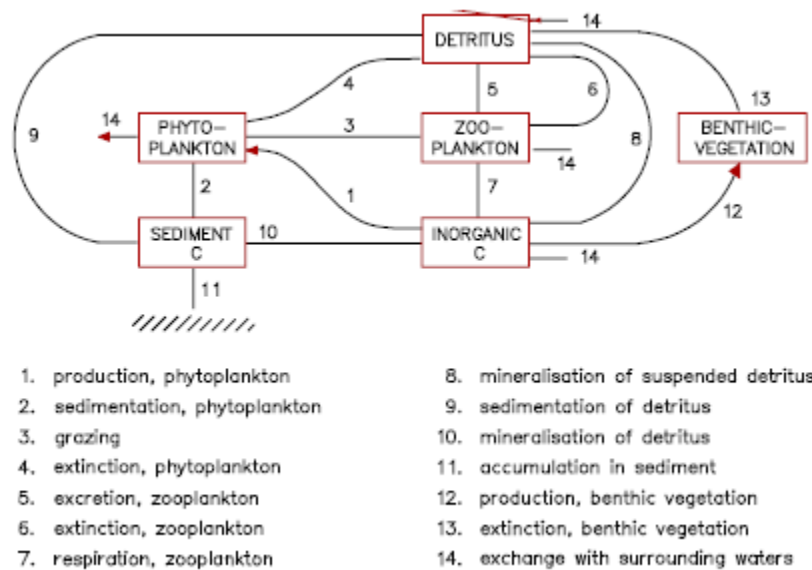

Figure 3.1 The simplified flow diagram of the fluxes of carbon, nitrogen and phosphorus in the eutrophication model

### 3.1 Phytoplankton Carbon (PC)

$$\frac{dPC}{dt} = \text{production} - \text{grazing} - \text{sedimentation} - \text{death} \tag{3.1}$$

$$= PRPC - GRPC - SEPC + SEPC^{n-1} - DEPC$$

Where  
n-1 denotes the input from the above layer (n>1).

NOTE: Only relevant for MIKE 3.

## 2: Factors Affecting Primary Production

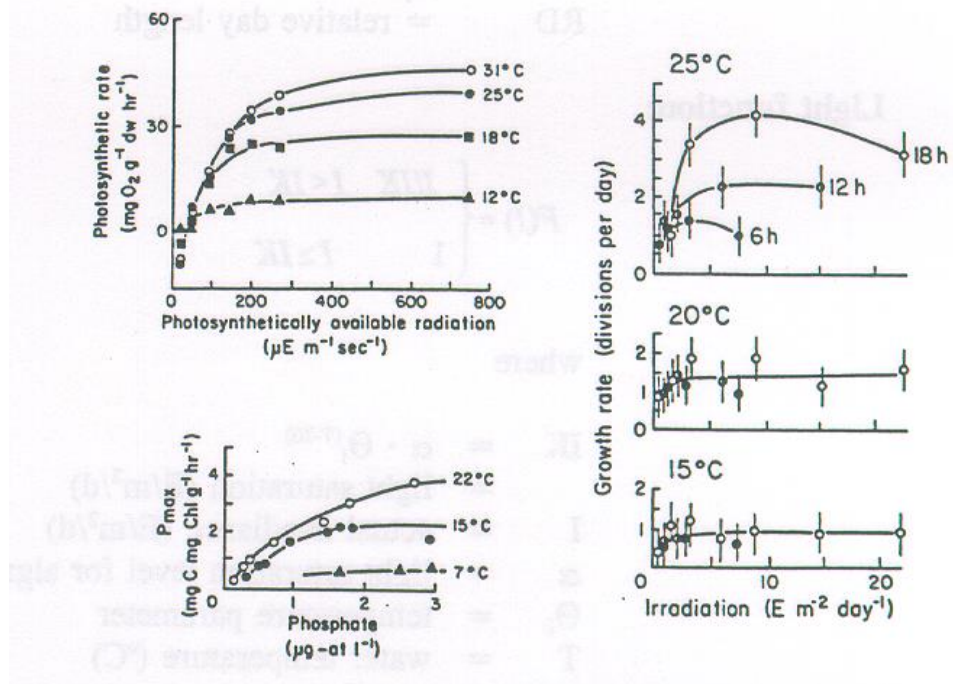

Figure 3.2 Interaction of temperature with light and nutrients. Top left: Photosynthetic rate of *Cladophora albida* under different levels of light intensity and temperatures in estuarine water. Adapted from Gordon et al. (1980). Right: Mean ( $\pm$  standard deviation) division rates during exponential phase of growth in *Talassiosira fluviatilis* at three temperatures and daylengths (18, 21, and 6 hrs). Adapted from Hobson (1974). © Canadian Journal of Aquatic and Fisheries Sciences. Bottom left: Maximum photosynthetic rate ( $P_{max}$ ) of natural phytoplankton of Tokyo Bay under varying phosphate concentrations and temperatures. Adapted from Ichimura (1967). (from: Valiela, 1984)

### Production (PRPC)

The net production of phytoplankton is light, temperature and nutrient dependent.

$$PRPC = \mu \cdot F(I) \cdot F_T(T) \cdot F_N(N,P) \cdot FAC \cdot RD \tag{3.2}$$

Where

- $\mu$  = maximum growth coefficient at 20°C (d<sup>-1</sup>)
- FAC = correction factor for dark reaction
- RD = relative day length

### Light function

$$F(I) = \begin{cases} I / IK & I < IK \\ 1 & I \geq IK \end{cases} \tag{3.3}$$

Where

$$IK = \alpha \cdot \Theta_i^{(T-20)} = \text{light saturation (E/m}^2\text{/d)}$$

$I$	= actual irradiance (E/m <sup>2</sup> /d)
$\alpha$	= light saturation level for algae at 20°C (E/m <sup>2</sup> /d)
$\Theta_i$	= temperature parameter
$T$	= water temperature (°C)

The irradiance at the surface (in E·m<sup>-2</sup>·d<sup>-1</sup>) is integrated analytically over depth until the depth of the actual layer, given the value of  $I$  in the light function. The light function then determines the relative light saturation level. In this model, the light saturation level may be made temperature-dependent, reflecting the observation that phytoplankton groups, such as dinoflagellates, that reach maximum abundance in late summer, have higher light saturation levels (Figure 3.2; cf. Valiela, 1984). In shallow, low-volume systems, where there is only a short lag between irradiance level and water temperature, a temperature dependency may be used to reflect physiological adaptation to ambient light intensity.

### Temperature function

$$F_I(T) = \theta_g^{(T-20)} \quad (3.4)$$

Where

$\Theta_g$  = temperature coefficient for growth

Temperature for phytoplankton plays a major role as a covariate with other factors. Phytoplankton at low temperatures maintain greater concentrations of photosynthetic pigments, enzymes and carbon (Steemann, Nielsen & Jørgensen, 1968), enabling more efficient use of light. There are strong interactions between temperature and  $\mu_{Max}$  at any light intensity, with day length and production, and with nutrient uptake. In general, all rates increase with increasing temperatures and the irradiance level where maximum photosynthesis is reached is shifted to higher values with increasing temperatures.

### Nutrient dependence function

Since phytoplankton growth depends essentially on the size of the internal nutrient pools, the nutrient-dependent growth limitation  $F_I(N,P)$  is calculated from the relative saturation of the internal N and P pools. Droop (1973, 1975) provides a theoretical basis for this approach which also has been incorporated in a theoretical model by Nyholm (1977) and in North Sea models by Mommaerts (1978), Tett et al. (1986) and Lancelot & Rousseau (1987).

$$F_I(N,P) = \frac{2}{\frac{1}{F(N)} + \frac{1}{F(P)}} \quad (3.5)$$

$$F(N) = \frac{PN/PC - PN_{min}}{PN_{max} - PP_{min}}$$

$$F(P) = \frac{(PP/PC - PP_{min}) \cdot (KC + PP_{max} - PP_{min})}{(PP_{max} - PP_{min}) \cdot (KC + PP/PC - PP_{min})}$$

Where

$PN_{min}, PN_{max}$  = minimum and maximum internal nitrogen content in algae (gN/gC), respectively

$PP_{min}, PP_{max}$  = minimum and maximum phosphorus content in algae (gP/gC), respectively

$KC$  = half saturation constant for phosphorus in phytoplankton (gP/gC)

### Death of phytoplankton (DEPC)

Natural mortality of phytoplankton, or autolysis, has been shown to be a significant phenomenon in the marine ecosystem (Jassby & Goldman, 1974) and this decay of blooms is partly mineralised in the water column (Lancelot et al., 1987). In this model, the natural mortality of phytoplankton increases as the internal nutrient pools decrease.

The death rate is assumed to be proportional to the nutritional status of the phytoplankton

$$DEPC = \mu_d \cdot F_2(N, P) \cdot PC \quad (3.6)$$

Where

$\mu_d$  = death rate under optimal nutrient conditions ( $d^{-1}$ )

$F_2(N, P)$  =  $\frac{1}{2} \cdot \{PN_{max}/(PN/PC) + PP_{max}/(PP/PC)\}$

$F_2(N, P)$  is a function with a minimum of 1. and a maximum when PN/PC and PP/PC ratios are at a minimum. The maximum value of  $F_2(N, P)$  depends on the specified  $PN_{min}$  and  $PP_{min}$  coefficients. The maximum value will typically be around 10.

### Sedimentation of phytoplankton (SEPC)

Nutrient-replete phytoplankton is able to adjust its buoyancy and hence, to minimise its sinking rate. Under conditions of nutrient-stress, with the internal nutrient pools at lower levels, sinking rates increase (Smayda, 1970, 1971).

At low water depth ( $h < 2$  m):

$$SEPC = \mu_s \cdot F_2(N, P) \cdot PC \quad (3.7)$$

and at water depth  $h \geq 2$  m:

$$SEPC = U_s / h \cdot F_2(N, P) \cdot PC \quad (3.8)$$

Where

$\mu_s$  = sedimentation rate parameter ( $d^{-1}$ )

$U_s$  = sedimentation velocity (m/d)

$h$  = water depth (m)

The internal pools of phytoplankton nutrients in this model are state variables, because their uptake dynamics are decoupled from the phytoplankton carbon assimilation

dynamics, resulting in time-varying PN/PC and PP/PC ratios. However, the nutrient pools being internal to the carbon-based phytoplankton, their source and sink terms are proportional to the corresponding phytoplankton carbon rates.

### 3.2 Phytoplankton Nitrogen (PN)

The mass balance for phytoplankton nitrogen reads:

$$\begin{aligned} \frac{dPN}{dt} &= \textit{uptake} - \textit{grazing} - \textit{sedimentation} - \textit{death} \\ &= UNPN - GRPN - SEPN + SEPN^{n-1} - DEPN \end{aligned} \quad (3.9)$$

Where

$n-1$  denotes the input from the above layer ( $n>1$ ).

**NOTE:** Only relevant for MIKE 3.

The rates are similar to the ones for phytoplankton carbon.

#### Uptake (UNPN)

A description of the nitrogen uptake from phytoplankton can be found in section about the inorganic nitrogen.

#### Grazing (GRPN)

$$GRPN = GRPC \cdot (PN/PC) \quad (3.10)$$

#### Sedimentation (SEPN)

$$SEPN = SEPC \cdot (PN/PC) \quad (3.11)$$

#### Death (DEPN)

$$DEPN = DEPC \cdot (PN/PC) \quad (3.12)$$

### 3.3 Phytoplankton Phosphorus (PP)

The mass balance for phytoplankton phosphorus reads:

$$\begin{aligned} \frac{dPP}{dt} &= \textit{uptake} - \textit{grazing} - \textit{sedimentation} - \textit{death} \\ &= UPPP - GRPP - SEPP + SEPP^{n-1} - DEPP \end{aligned} \quad (3.13)$$

Where  
 $n-1$  denotes the input from the above layer ( $n>1$ ).

**NOTE:** Only relevant for MIKE 3.

The rates are similar to the ones for phytoplankton carbon.

### Uptake (UPPP)

A description of the phosphorus uptake from phytoplankton can be found in section about the inorganic phosphorus.

### Grazing (GRPP)

$$GRPP = GRPC \bullet (PP/PC) \quad (3.14)$$

### Sedimentation (SEPP)

$$SEPP = SEPC \bullet (PP/PC) \quad (3.15)$$

### Death

$$DEPP = DEPC \bullet (PP/PC) \quad (3.16)$$

## 3.4 Chlorophyll-a (CH)

The mass balance for chlorophyll-a reads:

$$\begin{aligned} \frac{dCH}{dt} &= \text{production} - \text{death} - \text{sedimentation} \\ &= PRCH - DECH - SECH + SECH^{n-1} \end{aligned} \quad (3.17)$$

Where  
 $n-1$  denotes the input from the above layer ( $n>1$ ).

**NOTE:** Only relevant for MIKE 3.

### Production (PRCH)

$$PRCH = (CH_{\min} / IK) \bullet \exp(F_3(N, P)) \bullet PRPC \quad (3.18)$$

Where

$CH_{min}$  = coefficient determining the minimum chlorophyll-a production ( $E/m^2/d$ )<sup>-1</sup>

$F_3(N)$  =  $CH_{max} \cdot \{(PN/PC - PN_{min}) / (PN_{max} - PN_{min})\}$

$CH_{max}$  = coefficient determining the maximum chlorophyll-a production (n.u.) in the absence of nutrient limitation.

### Sedimentation (SECH)

$$SECH = SEPC \bullet (CH/PC) \quad (3.19)$$

### Death (DECH)

$$DECH = (DEPC + GRPC) \bullet (CH/PC) \quad (3.20)$$

## 3.5 Zooplankton (ZC)

The mass balance for zooplankton reads:

$$\begin{aligned} \frac{dZC}{dt} &= production - death \\ &= PRZC - DEZC \end{aligned} \quad (3.21)$$

### Grazing (GRPC)

The grazing rate (GRPC) by zooplankton:

$$GRPC = \mu_z \bullet F_2(T) \bullet \frac{1}{F(PC)} \bullet F(DO) \bullet ZC \quad (3.22)$$

Where

$\mu_z$  = maximum grazing rate constant at 20°C ( $d^{-1}$ )

As the density of prey items (phytoplankton in this case) increases, predators (zooplankton here) eat more prey. This functional response to prey density may take different forms: types I-III.

In the simplest, type I, response the predator population eats more in linear proportion to prey abundance until a satiation level is reached. This point is reached because the predator population is eating at capacity. Further increases in prey abundance have no effect on ingestion rates.

In a type II response the predator population increases consumption at decelerating rate as the density of prey increases until an asymptotic value is reached.



In this model a type III functional response has been formulated (see Valiela, 1984 for a review of the literature on types of functional response). Type III has a density-dependent portion where the rate of ingestion accelerates with increasing prey density. At higher prey densities the type III behaves much like the type II functional response, with the percentage mortality caused per predator becoming lower at increasing prey density down to an asymptotic value.

The parameters  $K_1$  and  $K_2$  determine the onset and the extent of the density-dependent portion of the functional response.

### Temperature function

$$F_2(T) = \theta_z^{(T-20)} \quad (3.23)$$

Where

$\Theta_z$  = temperature coefficient for grazing rate

### Phytoplankton dependence function

$$F(PC) = 1 + e^{(K_1 - K_2 \cdot PC)} \quad (3.24)$$

Where

$K_1, K_2$  = factors describing the grazing rate dependence on phytoplankton biomass (N.U. and  $m^3/g$  respectively)

### Oxygen dependence function

$$F(DO) = \frac{DO^2}{DO^2 + MDO} \quad (3.25)$$

Where

$MDO$  = oxygen concentration indicating depressed grazing rates due to oxygen depletion

### Production (PRZC)

The production is coupled closely to the grazing of phytoplankton:

$$PRZC = V_c \cdot GRPC \quad (3.26)$$

Where

$V_c$  = growth efficiency parameter for zooplankton (n.u.)

## Respiration (REZC)

Respiration of zooplankton can be described as proportional to the grazing of phytoplankton by ignoring basic metabolism, since activity respiration dominates respiratory processes.

$$REZC = K_R \cdot GRPC \quad (3.27)$$

Where  
 $K_R$  = proportionality constant

## Death (DEZC)

Zooplankton mortality has a density-independent term as in Horwood (1974). The density-dependent term is a closure term, which is necessary in the model because zooplankton is the highest trophic level explicitly modelled. For a discussion of the closure problem, see Steele (1976).

The zooplankton decay is proportional to the zooplankton concentration, but at high densities the dependence is of second order resulting in:

$$DEZC = K_{d1} \cdot ZC + K_{d2} \cdot ZC^2 \quad (3.28)$$

Where  
 $K_{d1}$  = rate constant ( $d^{-1}$ ) especially important at concentrations below  $1 \text{ g} \cdot \text{m}^{-3}$ .

$K_{d2}$  = rate constant important at high concentrations  
 $\{d^{-1} \cdot (\text{g}/\text{m}^3)^{-1}\}$

The zooplankton assimilation efficiency is not 100% resulting in an excretion (EKZC) of nutrients (C, N and P) being the difference between grazing, production and respiration:

$$EKZC = GRPC - PRZC - REZC \quad (3.29)$$

These excretion products are organic material entering the organic matter/detritus pool as outlined below in the detritus equations.

## 3.6 Detritus

Detritus is defined in the model as particles of dead organic material in the water. The detritus pool receives the dead primary producers and excreted material left after grazing. Sedimentation and mineralisation are the only processes draining the detritus pools.

There are three state variables: detritus carbon, nitrogen and phosphorus.

### 3.7 Detritus Carbon (DC)

The mass balance for detritus carbon reads:

$$\begin{aligned} \frac{dDC}{dt} &= \text{generation- sedimentation- mineralization} \\ &= (1 - VM) \bullet DEPC + EKZC + SLBC/h \\ &\quad - SEDC + SEDC^{n-1} - REDC + DEZC \end{aligned} \quad (3.30)$$

Where

$n-1$  denotes the input from the above layer ( $n>1$ ).

**NOTE:** Only relevant for MIKE 3.

#### Generation

The detritus generation is the sum of input from dead phytoplankton carbon (DEPC), dead zooplankton (DEZC), excretion of organic material from zooplankton (EKZC) and sloughing (or death) of benthic vegetation (SLBC).

Here

$V_m$  = fraction of dead phytoplankton, undergoing immediate mineralisation.

#### Sedimentation (SEDC)

The sedimentation of detritus is modelled similarly to the sedimentation of phytoplankton. At low water depths ( $h<2m$ ):

$$SEDC = \mu_d \bullet DC \quad (3.31)$$

and at water depth  $h>2m$ :

$$SEDC = U_d/h \bullet DC \quad (3.32)$$

Where

$\mu_d$  = sedimentation parameter for detritus at low water depth ( $d^{-1}$ )

$U_d$  = sedimentation rate parameter (velocity) for detritus (m/d)

#### Mineralisation (REDC)

Bacterioplankton has been included implicitly in the model by giving the detritus a variable mineralisation rate, which is dependent on temperature and oxygen saturation. Thus, detritus causes both oxygen consumption and inorganic nutrient regeneration in the water column and in the benthic system. This implicit approach has the obvious advantage of saving one state variable, but the disadvantage of having to ignore dissolved organic carbon (DOC) as a potential substrate for bacterioplankton.

However, since the largest single source of DOC in aerobic situations is exudation by primary producers with in situ rates of around 10% of net phytoplankton production (Williams, 1975, Smith et al., 1977) this omission is felt to be justifiable.

Nutrient regeneration from the benthic system by mineralisation processes is not dependent on the benthic detritus pool but on the sedimentation rate of pelagic detritus. Proportionality factors define the permanent loss of nutrients (adsorption, complexation, burial, denitrification) from the system.

$$REDC = \mu_m \cdot F_3(T) \cdot F_1(DO) \cdot DC \quad (3.33)$$

Where

$\mu_m$	= maximum mineralisation rate at 20°C (d <sup>-1</sup> )
$F_3(T)$	= $\Theta_D^{(T-20)}$
$\Theta_D$	= temperature coefficient for mineralisation of detritus
$F_1(DO)$	= $DO^2 / (DO^2 + MDO)$

### 3.8 Detritus Nitrogen (DN)

The main balance for detritus nitrogen reads:

$$\begin{aligned} \frac{dDN}{dt} &= \text{generation} - \text{sedimentation} - \text{mineralization} \\ &= (1 - VM) \cdot DEPN + EKZN + DEZN + SLBN - SEDN \\ &\quad + SEDN^{(n-1)} - REDN \end{aligned} \quad (3.34)$$

Where

$n-1$  denotes the input from the above layer ( $n > 1$ ).

**NOTE:** Only relevant for MIKE 3.

The rates are similar to the ones for detritus carbon.

#### Generation

Detritus nitrogen is the result of input from dead phytoplankton and excretion and death of zooplankton nitrogen. The excretion and death of zooplankton nitrogens are calculated from:

$$EKZN = VZN \cdot EKZC \quad (3.35)$$

$$DEZN = VZN \cdot DEZC$$

Where

$VZN$  = nitrogen content of zooplankton assumed to be constant (gN/gC)

The rate for sloughing of benthic nitrogen is calculated from:

$$SLBN = PNB \cdot (SLBC/h) \quad (3.36)$$

Where

$PNB$  = the nitrogen-carbon ratio in benthic vegetation assumed to be constant (gN/gC)

### Sedimentation

$$SEDN = SEDC \bullet DN/DC \quad (3.37)$$

### Mineralisation

$$REDN = REDC \bullet DN/DC \quad (3.38)$$

## 3.9 Detritus Phosphorus (DP)

The mass balance for detritus phosphorus reads:

$$\begin{aligned} \frac{dDP}{dt} &= \text{generation} - \text{sedimentation} - \text{mineralization} \\ &= (1 - VM) \bullet DEPP + EKZP + DEZP + SLBP - SEDP \\ &\quad + SEDP^{(n-1)} - REDP \end{aligned} \quad (3.39)$$

Where

$n-1$  denotes the input from the above layer ( $n > 1$ ).

**NOTE:** Only relevant for MIKE 3.

The rates for phosphorus are similar to the detritus carbon rates.

### Generation

This is the sum of phosphorus from dead phytoplankton, excretion and death of zooplankton phosphorus and sloughing of benthic vegetation phosphorus.

The excretion and death of zooplankton phosphorus and the sloughing of benthic phosphorus are expressed as:

$$\begin{aligned} EKZP &= VZP \bullet EKZC \\ DEZP &= VZP \bullet DEZC \\ SLBP &= PPB \bullet (SLBC/h) \end{aligned} \quad (3.40)$$

Where

$VZP$  = the constant phosphorus content of zooplankton (gP/gC)

$PPB$  = the constant phosphorus content of benthic vegetation (gP/gC)

### 3.10 Inorganic Nitrogen (IN)

The inorganic nitrogen is here modelled as the sum of ammonia, nitrate and nitrite. The main balance for inorganic nitrogen includes as a sink the uptake by the primary producers: phytoplankton (UNPN) and benthic vegetation (UNBN) and as a source the mineralisation of organic nitrogen (detritus) (REDN), zooplankton (REZN) and sedimented phytoplankton and detritus (RESN).

$$\frac{dIN}{dt} = \text{input from mineralization} - \text{uptake} \quad (3.41)$$

$$= REDN + REZN + RESN + VM \cdot DEPN - UNPN - UNBN$$

**NOTE:** For MIKE 3 only relevant for the bottom layer.

#### Input from mineralisation

The mineralisation rates for detritus and zooplankton are described above. The mineralisation of sediment, which is only relevant for the bottom layer, is described by:

$$RESN = K_{SN} \cdot F_5(T) \cdot F_2(DO) \cdot (SEDN + SEPN) \quad (3.42)$$

Where

$K_{SN}$	= proportionality factor at 20°C
$F_5(T)$	= $\Theta_M^{(T-20)}$
$F_2(DO)$	= $DO/(DO+MDO)$
$\Theta_M$	= temperature coefficient for mineralisation of sediment

The mineralisation is expressed as a fraction of the sedimentation of organic matter.

Under anoxic conditions, the release of nutrients is not only a result of recently sedimented material, but also a zero order function where large amounts of nutrient buried in the sediment will be released. This is described by a constant release rate per areal unit:

$$As \ DO < \ MDO \quad (3.43)$$

$$RESN = N_{REL}/h$$

where

$N_{REL}$  = release rate under anoxic conditions (g/m<sup>2</sup>/d)

#### Uptake

The "uptake" is both uptake by phytoplankton (UNPN) and by benthic vegetation (UNBN).

### Uptake by phytoplankton (UNPN)

The model for phytoplankton includes modelling of nutrient limited growth determined by intracellular concentrations. The uptake is then different for limited and non-limited conditions. Under limiting conditions where  $PN < PN_{max}$  the uptake rate of nitrogen is chosen from three expressions in the following way:

$$UNPN = \min \left[ \begin{array}{l} \max \left[ \begin{array}{l} V_{kn} \cdot \frac{IN}{IN + KPN} \cdot PC \\ Mineralization + external\ supply \end{array} \right. \\ PRPC \cdot PN_{max} \end{array} \right. \quad (3.44)$$

This scheme states that under limiting conditions the uptake is determined either by the extracellular concentration (IN) or by the release of nutrients by biological and chemical decomposition processes and external supply. The highest value of these two is chosen. This shall of course not exceed the uptake as determined by the production and maximum nitrogen content. The latter is also true for the non-limiting condition where a choice of the minimum of the following values is made:

$$UNPN = \min \left[ \begin{array}{l} V_{kn} \cdot \frac{IN}{IN + KPN} \cdot PC \\ PRPC \cdot PN_{max} \end{array} \right. \quad (3.45)$$

Where

$V_{kn}$  = the uptake rate constant for nitrogen ( $d^{-1} \cdot (mg/l)^{-1}$ )  
 $KPN$  = Halfsaturation concentration for N uptake (mg N/l)

### Uptake by benthic vegetation (UNBN)

The model for the benthic vegetation does not include a nutrient limited growth as a function of intracellular concentration but a slightly more simple approach in which the extracellular nutrient concentration may be growth limiting. The nutrient uptake is then proportional to the net production.

$$UNBN = PNB \cdot (PRBC/h) \quad (3.46)$$

Where

$PNB$  = nitrogen to carbon ratio (gN/gC)  
 $PRBC$  = production of benthic carbon (see later for the benthic vegetation mass balance)

The growth limitation function is described together with the production of benthic vegetation below.

### 3.11 Inorganic Phosphorus (IP)

The main balance for inorganic phosphorus (e.g. phosphate) reads:

$$\frac{dIP}{dt} = \text{input from mineralization - uptake} \quad (3.47)$$

$$= REDP + REZP + RESP^* + VM \cdot DEPP - UPPP - UPBP$$

**NOTE:** For MIKE 3 only relevant for the bottom layer.

The rates are very similar to the rates for nitrogen.

#### Input from mineralisation

The input from mineralisation is the sum of mineralisation of detritus, zooplankton and phytoplankton phosphorus and the release from the sediment.

Release from the sediment, which is only relevant for the bottom layer, is expressed as:

$$RESP = K_{SP} \cdot F_5(T) \cdot F_2(DO) \cdot (SEDP + SEPP) \quad (3.48)$$

Where

$K_{SP}$  = proportionality factor at 20°C

The remainder of the terms in this equation have been explained above.

Under anoxic conditions ( $DO < MDO$ ) a constant release rate is modelled:

$$RESP = P_{REL}/h \quad (3.49)$$

Where

$P_{REL}$  = constant release rate (g/m<sup>2</sup>/d)

#### Uptake

Uptake by phytoplankton is described similarly to the nitrogen uptake.

Under non-limiting conditions:

$$UPPP = \min \left[ \begin{array}{l} V_{kp} \cdot \frac{IP}{IP + KPP} \cdot PC \\ PRPC \cdot PP_{max} \end{array} \right] \quad (3.50)$$



and under limiting conditions:

$$UPPP = \min \left[ \begin{array}{l} \max \left[ \begin{array}{l} V_{kp} \cdot \frac{IP}{IP + KPP} \cdot PC \\ \text{Mineralization} + \text{external supply} \end{array} \right] \\ PRPC \cdot PP_{\max} \end{array} \right] \quad (3.51)$$

Where

- $V_{kp}$  = uptake rate for phosphorus ( $d^{-1} \cdot (mg\ P/l)^{-1}$ )
- $KPP$  = halfsaturation concentration for P uptake ( $mg\ P/l$ )

The uptake by benthic vegetation:

$$UPBP = PPB \cdot (PRBC/h) \quad (3.52)$$

Where

- $PPB$  = the phosphorus to carbon content ( $gP/gC$ )
- $PRBC$  = production of benthic vegetation explained later

### 3.12 Oxygen (DO)

The oxygen balance includes the oxygen production of the primary producers, the oxygen consumption by mineralisation and respiration and also the reaeration, e.g. the oxygen exchange between water and air. The mass balance then reads:

$$\begin{aligned} \frac{dDO}{dt} &= \text{production} - \text{consumption} + \text{reaeration} \\ &= ODPC + ODBC - ODZC - ODDC - ODSC - \\ &\quad V_m \cdot V_o \cdot DEPC + REAR \end{aligned} \quad (3.53)$$

#### Production

Oxygen is produced during the production of phytoplankton and benthic vegetation. A specific amount of oxygen is produced per gram of carbon, according to the basic

$$ODPC = V_o \cdot PRPC \quad (3.54)$$

$$ODBC = V_o \cdot (PRBC/h)$$

Where  
 $V_o$  = oxygen to carbon ratio at production ( $\text{gO}_2/\text{gC}$ )

## Consumption

The oxygen consumption is due to mineralisation of organic matter in water and sediment, to respiration of zooplankton and to mineralisation of the part of the phytoplankton, which is mineralised immediately without entering the detritus pool.

$$ODDC = V_o \bullet REDC \quad (3.55)$$

$$ODZC = V_o \bullet REZC$$

Mineralisation of dead phytoplankton:

$$V_o \bullet V_m \bullet DEPC \quad (3.56)$$

The sediment oxygen demand is related to the carbon mineralisation in the sediment which again is related to the sedimentation of organic matter (detritus and phytoplankton).

$$RESC = K_{MSC} \bullet F_5(T) \bullet F_2(DO) \bullet (SEPC + SEDC) \quad (3.57)$$

Where  
 $K_{MSC}$  = proportionality factor at 20°C and oxidised condition  
 $F_5(T)$  =  $\Theta_M^{(T-20)}$   
 $\Theta_M$  = temperature coefficient for mineralisation  
 $F_2(DO)$  =  $DO/(DO+MDO)$

The oxygen consumption is then found from:

$$ODSC = V_o \bullet RESC \quad (3.58)$$

## Reaeration

The reaeration is found from the oxygen saturation concentration and a reaeration rate:

$$REAR = K_{RA} \bullet (C_s - DO) \quad (3.59)$$

Where  
 $K_{RA}$  = reaeration rate ( $\text{d}^{-1}$ )  
 $C_s$  = oxygen saturation concentration ( $\text{g}/\text{m}^3$ )  
 $C_s = 14.652 - 0.0841 \cdot S + T \cdot \{0.00256 \cdot S - 0.41022 + T \cdot (0.007991 - 0.0000374 \cdot S - 0.000077774 \cdot T)\}$   
 $T$  = water temperature ( $^{\circ}\text{C}$ )  
 $S$  = Salinity (o/oo)

### 3.13 Benthic Vegetation (BC)

The benthic vegetation is assumed to be rooted and/or attached to stones etc. Fixed nitrogen to carbon and phosphorus to carbon ratios are assumed. The mass balance for the benthic vegetation is:

$$\frac{dBC}{dt} = \text{production} - \text{loss} = PRBC - SLBC \quad (3.60)$$

#### Production (PRBC)

$$PRBC = \mu_B \cdot F_6(T) \cdot F_3(I) \cdot F_4(N, P) \cdot RD \cdot BC \quad (3.61)$$

Where

$\mu_B$  = net specific growth rate at 20°C

$RD$  = relative day length

$F_6(T)$  =  $\Theta_B^{(T-20)}$

$\Theta_B$  = temperature coefficient for benthic vegetation growth

$$F_2(I) = \begin{cases} I_B / I_{KB}, & I_B < I_{KB} \\ 1, & I_B \geq I_{KB} \end{cases}$$

$I_B$  = light intensity at bottom (E/m<sup>2</sup>/d)

$I_{KB}$  = light saturation intensity for the benthic vegetation (E/m<sup>2</sup>/d)

$$F_4(N, P) = \frac{2}{\left( \frac{1}{F_2(N)} + \frac{1}{F_2(P)} \right)}$$

$$F_2(N) = \frac{IN}{IN + KBN}$$

$KBN$  = Half saturation constant for the nitrogen limitation function (g/m<sup>3</sup>)

$$F_2(P) = \frac{IP}{IP + KBP}$$

$KBP$  = half saturation constant for the phosphorus limitation function (g/m<sup>3</sup>)

#### Loss / sloughing (SLBC)

$$SLBC = \mu_S \cdot F_7(T) \cdot (BC - BABC) \quad (3.62)$$

Where

$\mu_s$

= sloughing or loss rate at 20°C ( $d^{-1}$ )

$F_7(T)$

=  $\Theta_s^{(T-20)}$

$\Theta_s$

= temperature coefficient for loss

$BABC$

= minimum area based biomass of benthic vegetation ( $g/m^2$ )

## 4 Extended Description of Macroalgae and Rooted Vegetation

### 4.1 Macroalgae

The extended description of macroalgae includes three state variables: macroalgae carbon (BC), -nitrogen (BN) and – phosphorus (BP). The macroalgae submodel consists of 3 differential equations, one for each state variable. Each equation contains the rates describing algae production and death.

$$dBC/dt = \text{production} - \text{death} = PRBC - DEBC$$

$$dBN/dt = \text{uptake of nitrogen} - \text{death} \cdot BN/BL$$

$$dBP/dt = \text{uptake of phosphorus} - \text{death} \cdot BP/BL$$

The description of the production of macroalgae C (PRBC) is the same as the standard EU description of production of benthic vegetation C. The death is dependent on temperature and a death rate  $kslm$ :

$$DEBC = kslm \cdot tet^{temp-20} \cdot BC \quad (4.1)$$

The nutrient uptake (N and P) of macroalgae is very similar to the description of nutrient uptake of phytoplankton with a nutrients dependence function

### 4.2 Rooted Vegetation

The model describes the seasonal variations in the aboveground production and biomass of rooted vegetation. Two types of growth (production) are included: one is leaf elongation (i.e. increase in shoot biomass) and the other is development of new shoots. The above ground biomass is the mean biomass of a shoot times the number of shoots  $pr\ m^2$ .

Both young and old shoots, young and large shoots are seen in an eelgrass population at all times of the year. Nevertheless, small shoots are dominating in winter/spring and large shoots are dominating in summer/autumn. Assuming the seasonally varying mean biomass of a shoot to be representative for the size of the shoots in the population is therefore reasonable.

The net production of one shoot as well as the evolution of new shoots is depending on external forcing functions as light and temperature. Nutrient limitations of growth are not accounted for in the model. It is assumed that eelgrass can get sufficient nutrients from either the water or the sediment

The description of rooted vegetation e.g. eelgrass includes two state variables, mean biomass of one shoot (EC) and the number of shoots (NNEC).

$$dEC/dt = \text{production} - \text{death} = PREC - DEEC$$

$$dNNEC/dt = \text{production of shoots} - \text{loss off shoots} = DNNDT - PLOSS$$

Production of rooted vegetation biomass per shoot is described with the expression PREC:

$$PREC = megr \cdot myie \cdot RD \cdot EC \cdot ft1 \quad (4.2)$$

Where

*megr* = Growth rate

*myie* = Light function describing the growth dependence on light at the bed

*RD* = Relative day length

*ft1* = Arrhenius temperature expression =  $teta1^{temp-20}$

*teta1* = Temperature coefficient for rooted vegetation growth

Loss of rooted vegetation biomass per shoot is described by the expression DEEC:

$$DEEC = medr \cdot ft2 \cdot fh2 \cdot EC \quad (4.3)$$

Where

*medr* = Death rate

*ft2* = Arrhenius temperature expression:  $ft2 = teta2^{temp-20}$

*teta* = Temperature coefficient for rooted vegetation shoot death

*fh2* = Factor for depth dependent death. The factor can be used to describe death as a result of wave impact at shallow water:

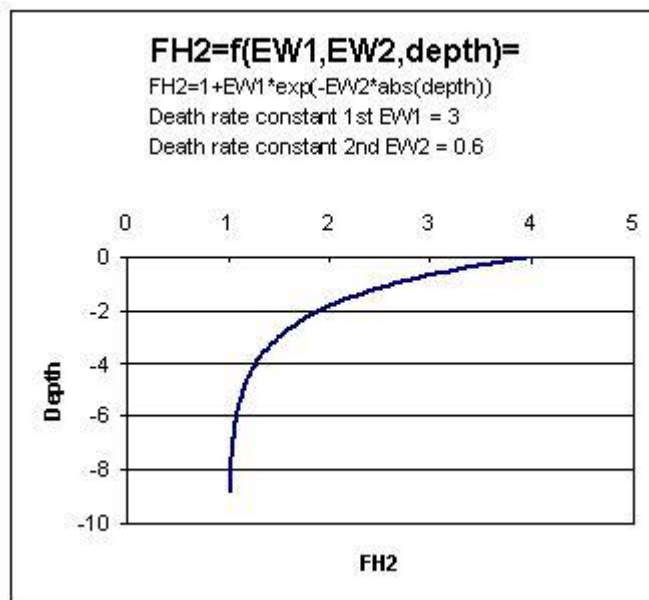

The production of new shoots is described with the expression DNDT:

$$DNDT = mngr \cdot myie \cdot ft1 \cdot RD \quad (4.4)$$

Where

<i>mng</i>	= Growth rate for shoot density
<i>my</i>	= Light function describing the growth dependence on light at the bed. The light function for shoot production include benthic shading
<i>RD</i>	= Relative day length
<i>ft1</i>	= Arrhenius temperature expression = $t_{eta1}^{temp-20}$
<i>teta1</i>	= the temperature coefficient for rooted vegetation growth

The loss of shoots is described by the expression PLOSS:

$$PLOSS = kloss \cdot NNEC \quad (4.5)$$

Where  
*kloss* = Loss rate for shoot density





## 5 Extended Sediment Description

The Standard Eutrophication model has a simple description of sediment release of nitrogen and phosphorus which returns a fraction of the settled P to the sediment back into the water column. This approach has shown sufficient when describing systems with moderate nutrient loading or with low retention time. However in systems with high loading and/or high retention time the description has shown to be insufficient.

The sediment module is an add-on module to the standard EU module and therefore uses the state variables and some of the processes as input. The sediment module is constructed in a way so it is possible to use in connection with other add on module like the eelgrass module.

The present description is restricted to the Sediment but may use terms from the Standard EU description.

### 5.1 N and P Cycle in the Sediment Module

The state variables and the processes in the sediment model are listed below and presented in Figure 5.1 and Figure 5.2 for nitrogen and phosphorus respectively.

The nitrogen cycle consists of three state variables and one sink: Organic N in the sediment (SON), total  $\text{NH}_4$  (SNH),  $\text{NO}_3$  (SNO<sub>3</sub>) and immobile nitrogen (SNIM).

Sedimentation of organic N or flux of  $\text{NH}_4$  and  $\text{NO}_3$  across the sediment surface connects the state variables to plankton N, detritus N and inorganic N in the water. The organic N in the sediment is mineralised producing  $\text{NH}_4$ , which enters the SNH pool.  $\text{NH}_4$  in the sediment may either be exchanged with IN in the water or nitrified to  $\text{NO}_3$  in the uppermost layer of the sediment with  $\text{O}_2$ .

The  $\text{NO}_3$  entering the SNO<sub>3</sub> pool may either be denitrified or exchanged with inorganic N in the water.

The phosphorus cycle in the sediment consist likewise of three state variables and a sink: leachable organic P, (SOP),  $\text{PO}_4$ -P in pore water (SIP),  $\text{PO}_4$ -P adsorbed to  $\text{Fe}^{+++}$  (SPFE) and immobile P (SIMP).

A fraction of the plankton P and detritus P which settles on the sediment surface is undergoes decomposition or are eaten by deposit feeders in the sediment before it is incorporated into the sediment. Some of the P will therefore be turned to  $\text{PO}_4$  and the rest will enter the pool of organic P in the sediment. The processes FSPB and RSOP describe these fluxes of P, see Figure 5.1.

A fraction of the P entering the sediment surface will be buried in deeper sediment layers chemical bound to apatite ( $\text{CaCO}_3$ ) or to refractory organic matter, Jensen/1995/ and Sundby/1992/. This is described in the model by letting a fraction of the organic P go into the pool of immobilised P (SIMP).

The pool of leachable organic P (SOP) is degraded to  $\text{PO}_4$  (process ROPSIP) and released into the pore water pool of  $\text{PO}_4$  (SIP). Besides the organic P, the pool of adsorbed  $\text{PO}_4$  to oxidised Fe shown to be the most important P component for the P cycle

in marine coastal sediments, ref. Mortensen /1992/ and Jensen /1995/. Therefore a pool of PO<sub>4</sub> adsorbed to Fe<sup>+++</sup> has been included in the module (SPFE). Adsorption and desorption to Fe<sup>+++</sup> is determined by the concentration of PO<sub>4</sub> in the sediment.

Fe will only be on oxidised form in the layers with O<sub>2</sub> or NO<sub>3</sub>. The thickness of these layers, are subject to changes over a year, and so will the pool of Fe<sup>+++</sup> in the sediment. The Pool of Fe<sup>+++</sup> and thereby also the pool of SPFE are made dependent on the penetration depth for NO<sub>3</sub> in the sediment. A flux of PO<sub>4</sub>-P across the sediment surface from the sediment is included in the model as a function of the concentration difference between water and sediment PO<sub>4</sub>.

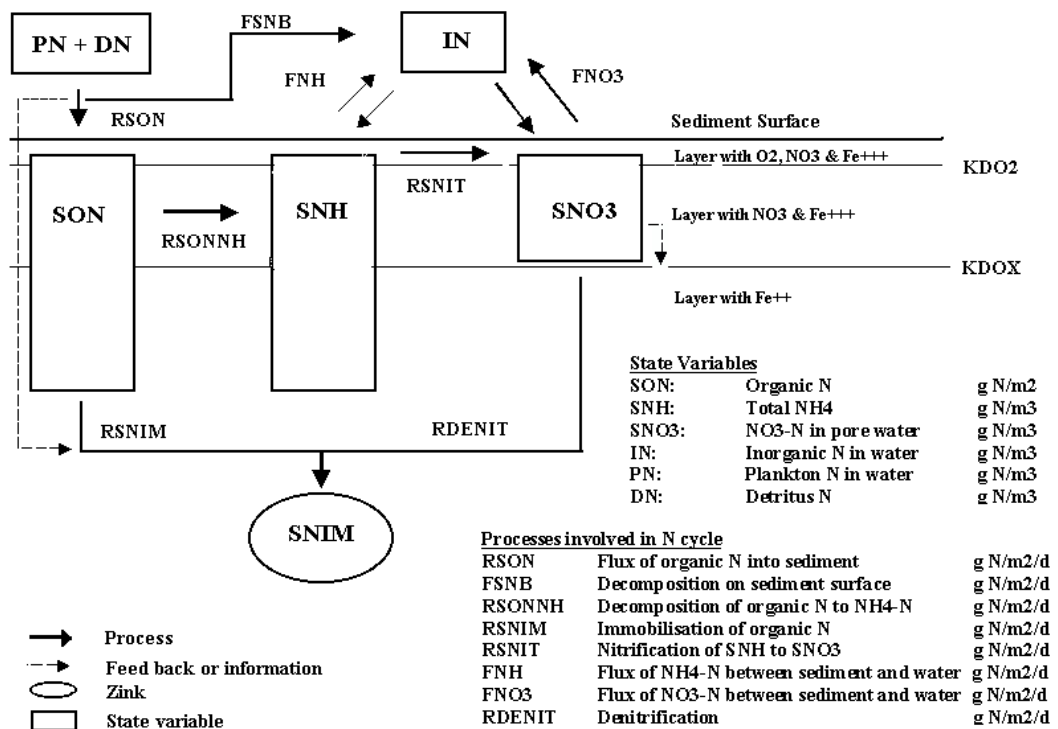

Figure 5.1 Nitrogen cycle in sediment module

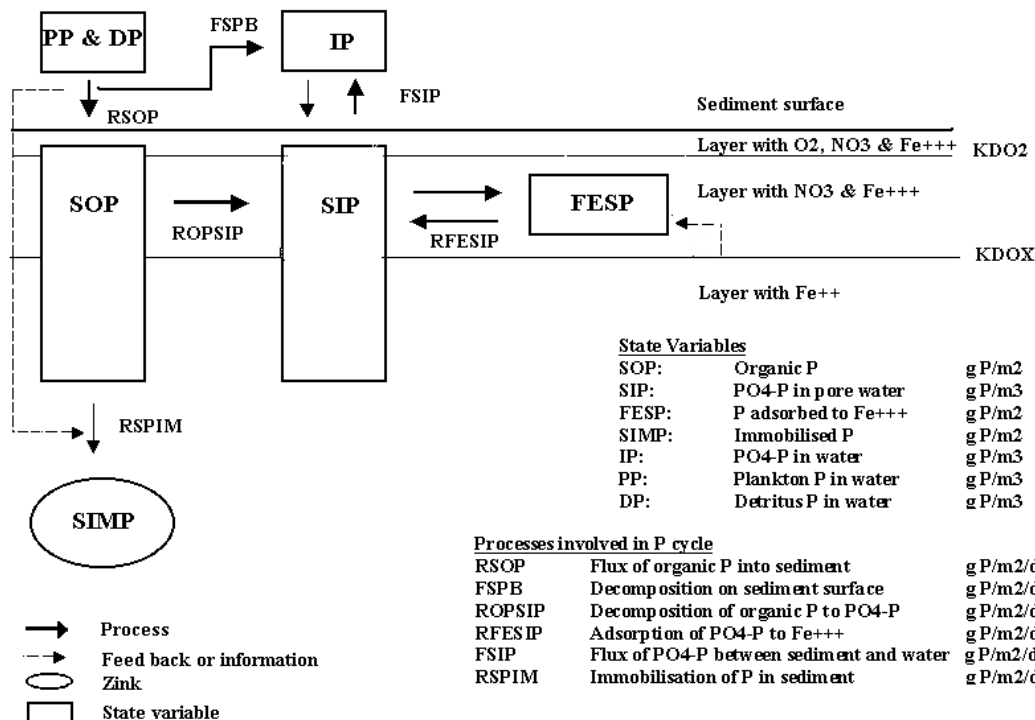

Figure 5.2 P cycle in sediment module

## 5.2 Nitrogen Processes

The processes in a dynamic model describe the changes in and fluxes between state variables e.g. nitrification of NH<sub>4</sub> to NO<sub>3</sub> in the sediment. Together with the state variables the processes may be regarded as the cornerstones in a dynamic model.

The processes involved in the nitrogen cycle are described in connection to the state variables.

### Organic N in sediment (SON)

Input of new organic N to the sediment is mediated by sedimentation of living algae or dead organic matter from the overlaying water column. When the organic matter reaches the sediment surface, it often forms a loose layer of material, which is easily resuspended. Degradation of material, in this thin layer is fast compared to the under-laying sediment layer. In the sediment the organic material will degrade releasing nitrogen as NH<sub>4</sub> to the pore water. However as the C: N ration in the remaining organic matter increases the degradation decreases because the organic matter do not fulfil the needs of nitrogen for bacteria and other organisms involved in this mineralisation. At a molar C: N ratio of about 11 the net mineralisation of NH<sub>4</sub> seems to stop, Blackburn, 1983.

In the model input of organic N to the sediment is calculated by the standard EU as sedimentation of algae N and detritus N, SEPN and SEDN respectively. A fraction of the settled organic N is assumed to be degraded returning the N to inorganic N in the water. This process (FSNB) is temperature dependent and should account for the relative fast

mineralisation of organic material in the surface layer. The remaining organic N (RSON) is put into the pool of organic N in the sediment (SON).

A fraction of the settled nitrogen is assumed to be buried in the sediment. This fraction (RSNIM) is defined as the part of the settled nitrogen of the settled organic matter with a C:N ratio above about 11. The pool of organic N is mineralised with NH<sub>4</sub> as the end product, this process (RSONNH) is set to be a temperature dependent fraction of SON

### Mineralisation of newly settled organic N

$$FSNB = KRESNO * (SEDN + SEPN + SEEN) * TETN^{(TEMP-20)}$$

(5.1)

*g N/m<sup>3</sup>/d*

### Input of N to sediment pool of organic N

$$RSON = (SEPN + SEDN + SEEN - FSNB) * MADE$$

(5.2)

*g N/m<sup>2</sup>/d*

### Burial of organic N in sediment

*if*  
 $(SEPC + SEDC + SEEC) * MADE * KNIM \leq RSON$   
*then*  
 $RSNIM = (SEPC + SEDC + SEEC) * MADE * KNIM$   
*else*  
 $RSNIM = RSON$

(5.3)

*g N/m<sup>2</sup>/d*

### Mineralisation of SON in the sediment

$$RSONNH = SON * KRSN1 * TETN^{(TEMP-20)}$$

(5.4)

*g N/m<sup>2</sup>/d*

Where		
<i>KRESNO</i>	Fraction mineralised at 20 C,	
<i>SEPN</i>	Sedimentation of PN (plankton N)	<i>g N/m<sup>3</sup>/d</i>
<i>SEPC</i>	Sedimentation of PC (plankton C)	<i>g C/m<sup>3</sup>/d</i>
<i>SEDN</i>	Sedimentation of DN (detritus N)	<i>g N/m<sup>3</sup>/d</i>
<i>SEDC</i>	Sedimentation of DC (detritus C)	<i>g C/m<sup>3</sup>/d</i>
<i>SEEN</i>	Input to sediment of N in dead eelgrass, (option)	<i>g N/m<sup>3</sup>/d</i>
<i>SEEC</i>	Input to sediment of C in dead eelgrass, (option)	<i>g C/m<sup>3</sup>/d</i>
<i>TEMP</i>	Water temperature,	<i>C</i>

<i>MADE</i>	Depth of water layer above sediment	m
<i>KNIM</i>	N:C ratio below which no mineralisation	g N/g C
<i>KRSN1:</i>	Mineralisation rate SON	1/d

### Total NH<sub>4</sub> in the sediment (SNH)

The total NH<sub>4</sub> in the sediment is defined as the NH<sub>4</sub>, which may be extracted with a KCl solution. A part, and sometime a major part, of this NH<sub>4</sub> is loosely sorbed to particles in the sediment. In the model it is assumed that fraction is available for nitrification and flux across the sediment surface.

Three processes are connected to this state variable, mineralisation of SON, nitrification, and flux of NH<sub>4</sub> across the sediment water surface. For mineralisation of SON, see under SON.

Bacteria in the sediment mediate nitrification by oxidising NH<sub>4</sub> to NO<sub>2</sub> and NO<sub>3</sub> using O<sub>2</sub>. In the model nitrification is calculated by multiplying a potential nitrification capacity with a Monod kinetics for NH<sub>4</sub> in the sediment and a Monod kinetics for squared O<sub>2</sub> concentration in the water. As nitrification is an aerobic process it will be restricted to the sediment layer with O<sub>2</sub>.

The flux of NH<sub>4</sub> between sediment and water is a process depending of the concentration difference between water and sediment and the total diffusion for NH<sub>4</sub>.

In the standard EU model, NH<sub>4</sub> and NO<sub>3</sub> is lumped together as inorganic N (IN). It is therefore necessary to assume that the ratio of NH<sub>4</sub> and NO<sub>3</sub> in the water just above the sediment surface has the same ratio as in the sediment. First the flux of NH<sub>4</sub> and NO<sub>3</sub> across the sediment is calculated, then the flux of NH<sub>4</sub> is calculated.

### Nitrification of total NH<sub>4</sub> in sediment

$$RSNIT = KNIT * KDO2 * \frac{SNH}{SNH + KSNH0} * \frac{DO^2}{DO^2 + MDO} * TETN^{(TEMP-20)} \quad (5.5)$$

*g N/m<sup>2</sup>/d*

### Flux of SNH + SNO<sub>3</sub> between sediment and water

$$FNHNO3 = DIFN * \frac{SNH + SNO3 - IN}{KDOX} \quad (5.6)$$

*g N/m<sup>2</sup>/d*

### Flux of SNH between sediment and water

$$FNH = FNHNO3 * \frac{SNH}{SNH + SNO3} \quad (5.7)$$

*g N/m<sup>2</sup>/d*

Where		
<i>KNIT</i>	Potential nitrification at 20 C in sediment	g N/m <sup>3</sup> /d
<i>KDO2</i>	Layer with O <sub>2</sub> , see below	m
<i>KSNH0</i>	Half saturation concentration for SNH	gN/m <sup>3</sup>
<i>DO</i>	O <sub>2</sub> in water	g O <sub>2</sub> /m <sup>3</sup>
<i>MDO</i>	Half saturation concentration for O <sub>2</sub>	g O <sub>2</sub> /m <sup>3</sup>
<i>DIFN</i>	Diffusion of SNH in sediment	m <sup>2</sup> /d
<i>KDOX</i>	Layer with NO <sub>3</sub> , see below	m

To be able to calculate the nitrification and the flux of SNH it is necessary to know the O<sub>2</sub> and NO<sub>3</sub> penetration into the sediment.

In coastal areas the O<sub>2</sub> penetration in the sediment will be a few mm. An empirical relation has been established for a silty coastal sediment in Denmark, Gundresen, 1995. This relation has been used in the model.

### O<sub>2</sub> penetration into sediment

$$KDO2 = KKA + KKB * DO - KKC * ODSC * MADE \quad m \quad (5.8)$$

Where		
<i>KKAMin.</i>	O <sub>2</sub> penetration	m
<i>KKBO<sub>2</sub></i>	O <sub>2</sub> dependent O <sub>2</sub> penetration	m <sup>4</sup> /g O <sub>2</sub>
<i>KKCSed.</i>	respiration dependent O <sub>2</sub> penetration	d*m <sup>3</sup> /g O <sub>2</sub>
<i>ODSC</i>	Total sediment O <sub>2</sub> consumption	g O <sub>2</sub> /m <sup>3</sup> /d
<i>MADE</i>	Thickness of water layer above sediment	m

Below the layer with oxygen NO<sub>3</sub> will take over as an electron acceptor keeping Fe and Mn on an oxidised form. The NO<sub>3</sub> respiration or denitrification is mediated by bacteria in the sediment.

The penetration of NO<sub>3</sub> can be calculated using Ficks 1<sup>st</sup> law and assuming a constant denitrification, diffusion of NO<sub>3</sub> with depth, knowing the NO<sub>3</sub> concentration in the layer with O<sub>2</sub> and assuming NO<sub>3</sub> concentration is 0 at the depth *KDOX*.

### NO<sub>3</sub> penetration into the sediment is then

Using Ficks 1<sup>st</sup> law and assuming steady state conditions:

$$0 = DIFN * \frac{d^2C}{dx^2} + DNM3 \quad (5.9)$$

By integration:

$$\frac{dC}{dx} = \frac{DNM3}{DIFN} * x + a \quad (5.10)$$

The constant *a* can be defined using  $\frac{dC}{dx} = 0$  for  $x = Kd$

$$a = -\frac{DNM3}{DIFN} * Kd \tag{5.11}$$

By yet an integration, the concentration *C* can be found:

$$C = \frac{DNM3}{2 * DIFN} * x^2 - \frac{DNM3}{DIFN} * Kd * x + b \tag{5.12}$$

The constant *b* can be defined using *C = 0* for *x = Kd*.

$$b = \frac{DNM3}{2 * DIFN} * Kd^2 \tag{5.13}$$

$$KDOX = \sqrt{\frac{SNO3 * 2 * DIFN}{DNM3}} + KDO2 \tag{5.14}$$

*m*

Where

<i>DNM3</i> .	Denitrification	g N/m <sup>3</sup> /d
<i>DIFN</i>	Diffusion of NO <sub>3</sub> in sediment	m <sup>2</sup> /d
<i>x</i>	Sediment depth, x=0 at KDO2	m
<i>C</i>	Concentration of NO <sub>3</sub> in sediment	g NO <sub>3</sub> -N/m <sup>3</sup>
<i>Kd</i>	Depth from KDO2 where NO <sub>3</sub> =0	m

### NO<sub>3</sub> in sediment (SNO3)

Three processes are determining the NO<sub>3</sub> concentration in the sediment nitrification, denitrification and flux of NO<sub>3</sub> between sediment and water. The nitrification has been described under SNH.

The flux of NO<sub>3</sub> across the sediment surface is calculated in the same way as the flux of NH<sub>4</sub>.

### Flux of NO<sub>3</sub> across sediment surface

$$FNO3 = FNHNO3 - FNH \tag{5.15}$$

*g N/m<sup>2</sup>/d*

The denitrification (RDENIT) or flux of NO<sub>3</sub> into the sediment is calculated using Ficks 1<sup>st</sup> law.

### Denitrification

$$RDENIT = -DIFN * \frac{dC}{dx} \tag{5.16}$$

*for x = 0*

$\frac{dC}{dx}$  see under  $\text{NO}_3$  penetration into sediment

$$RDENIT = \sqrt{2 * DIFN * DNM3} \quad (5.17)$$

Where

$$DNM3 = DEMAX * TETN^{(TEMP-20)} \quad (5.18)$$

$g \text{ N/m}^2/\text{d}$

### Immobilisation of N in sediment (SNIM)

Immobilisation of N may occur either as burial of slowly degradable organic N or as denitrification of  $\text{NO}_3$ . The processes have been described under SON and SNO3 respectively.

## 5.3 Phosphorus Processes

The below description of the phosphorus processes is made according to the state variables in the P cycle.

### Leachable organic P in sediment (SOP)

SOP is a pool of leachable organic P, which is able to be turned into  $\text{PO}_4$  by mineralisation. Input to SOP occur through sedimentation of algae P and detritus P to the sediment surface, a fraction of the settled organic P is mineralised on the sediment surface represented by the flux FSPB. However a part of the settled P will be immobilised in the sediment either as refractive organic P or as apatite P. In the model the immobilisation is calculated as a fraction of RSOP which enters the pool of immobilised P, SIMP. The remaining of the settled organic P enters SOP

### Mineralisation of newly settled organic P

$$FSPB = KRESPO * (SEDP + SEPP + SEEP) * TRSP^{(TEMP-20)} \quad (5.19)$$

$g \text{ P/m}^3/\text{d}$

### Input of P to sediment pool of organic P

$$RSOP = (SEPP + SEDP + SEEP - FSPB) * MADE \quad (5.20)$$

$g \text{ P/m}^2/\text{d}$

### Burial of organic P in sediment

$$RSPIM = RSOP * KPIM \quad (5.21)$$



$g P/m^2/d$

### Mineralisation of SOP in the sediment

$$ROPSIP = SOP * KRSP1 * TRSP^{(TEMP-20)} \quad g P/m^2/d \quad (5.22)$$

Where		
<i>KRESP0</i>	Fraction mineralised at 20 C	
<i>SEPP</i>	Sedimentation of PP (plankton P),	$g P/m^3/d$
<i>SEDP</i>	Sedimentation of DP (detritus P),	$g P/m^3/d$
<i>SEEP</i>	Input to sediment of P in dead eelgrass, (option)	$g P/m^3/d$
<i>TEMP</i>	Water temperature,	C
<i>MADE</i>	Dept of water layer above sediment	m
<i>KRSP1</i>	Mineralisation rate SOP	1/d

### PO<sub>4</sub> in pore water (SIP) and PO<sub>4</sub> adsorbed to Fe<sup>+++</sup> (SPFE)

PO<sub>4</sub> in pore water may either adsorbed to Fe<sup>+++</sup> (SPFE) or exchanged with PO<sub>4</sub> in the water across the sediment surface. The equilibrium of PO<sub>4</sub> adsorbed to Fe<sup>+++</sup> is described as a product between a P sorption capacity, which is depending of the amount of F<sup>+++</sup>, and a Monod relation of SIP, Jacobsen, 1997 and 1998.

The adsorption or desorption of PO<sub>4</sub> is then defined as the change in SPFE caused by a change the concentration of SIP or a change in the amount of Fe<sup>+++</sup>, which is dependent of the penetration depth of NO<sub>3</sub>. (KDOX).

### Sorption and desorption of PO<sub>4</sub> to Fe<sup>+++</sup>

$$RFESIP = KRAP$$

$$*(KFE * KFEPO * \frac{SIP}{SIP + KHFE} * VF * DM * 10^6 \quad g P/m^2/d \quad (5.23)$$

$$*KDOX - SPFE_{t-1})$$

### Flux of PO<sub>4</sub> between sediment and water

$$FSIP = KFIP * \frac{SIP - IP}{KDOX} \quad g P/m^2/d \quad (5.24)$$

Where		
<i>DM</i>	Dry matter of sediment, specified by user	$g DM/g ww$
<i>VF</i>	Specific gravity, specified by user	$g ww/cm^3$
<i>SPFE<sub>t-1</sub></i>	SPFE to time t-1	$g P/m^2$

## 5.4 Differential Equations

The change in the state variable with time is calculated by adding all the processes together in a differential equation set up for each state variable.

Below the differential equations are defined:

$$\frac{dSON}{dt} = \frac{RSON - RSONNH - RSNIM}{g \text{ N/m}^2/\text{d}} \quad (5.25)$$

$$\frac{dSNH}{dt} = \frac{RSONNH - RSNIT - FNH}{(1 - DM) * VF * KDO2} \quad (5.26)$$

$g \text{ N/m}^3/\text{d}$

$$\frac{dSNO3}{dt} = \frac{RSNIT - RDENIT - FNO3}{(1 - DM) * VF * KDS} \quad (5.27)$$

$g \text{ N/m}^3/\text{d}$

$$\frac{dSNIM}{dt} = RSNIM + RDENIT \quad (5.28)$$

$g \text{ N/m}^2/\text{d}$

$$\frac{dSOP}{dt} = \frac{RSOP - ROPSIP - RSPIM}{g \text{ P/m}^2/\text{d}} \quad (5.29)$$

$$\frac{dSIP}{dt} = \frac{-RFESIP + ROPSIP - FSIP}{(1 - DM) * VF * KDS} \quad (5.30)$$

$g \text{ P/m}^3/\text{d}$

$$\frac{dSPFE}{dt} = RFESIP \quad (5.31)$$

$g \text{ P/m}^2/\text{d}$

$$\frac{dSPIM}{dt} = RSPIM \quad (5.32)$$

$g \text{ P/m}^2/\text{d}$

Where

<i>DM</i>	Dry matter of sediment, specified by user	g DM/g ww
<i>VF</i>	Specific gravity, specified by user	g ww/cm <sup>3</sup>
<i>KDS</i>	Depth of active sediment layer, specified by user	m

## 5.5 Parameters

The tables below include parameters for the N and P cycle respectively.

Eutrophication Specifications, Sediment N	Name	Suggested Value	References*)
Fraction of settled N mineralised on sediment	krsn0	0.2	Calibrated
Mineralisation of SON, 1/h	krsn1	0.0001	Calibrated,15
N:C ratio of immob. Org. N in sediment g N/g C	knim	0.064	15
Teta, mineralisation of SON in sediment	tetn	1.04	Calibrated
Nitrification rate sediment, g N/m <sup>3</sup> /h	knit	0.1	1,2,15
Nitrificat. sediment, half saturat. conc. g N/m <sup>3</sup>	ksnh0	0.5	Calibrated
Halfsaturation conc. For eelgrass uptake of SNH, g N/m <sup>3</sup>	ksen	0.9	Calibrated 11,12,13

Eutrophication Specifications, Sediment P	Name	Suggested Value	References
Teta for temperature, mineralisation of SOP	trsp	1.04	Calibrated
Max. denit. sediment 20 C, g N/m <sup>3</sup> /h	demax	0.035	1
Immobile P fraction of settled P,	kpim	0.15	Calibrated,6
Fraction of settled P mineralised at surface	krsp0	0.2	Calibrated
mineralisation of SOP, 1/h	krsp1	0.0001	Calibrated,15
Depth of active sediment layer, m	kds	0.1	User defined
Chemosorption of P to Fe <sup>+++</sup> , g P/g Fe	kfepo	0.066	5,6,7,8
Const. DO penetration in sediment, m	kka	0.00124	9
Const. DO penetration in sediment, m/DO	kkb	0.000403	9
Const. Do penetration in sediment, h*m <sup>3</sup> /DO	kkc	0.00132	9
Diffusion to from sed of SIP, m <sup>2</sup> /h	kfip	0.00001	1,17
Fe <sup>+++</sup> conc. in surface sediment, g Fe/g DM	kfe		User defined
Dry weight sediment, g DM/g WW	dm		User defined
Mass/vol. of sediment, tonnes/m <sup>3</sup>	vf		User defined
Halfsaturation Fe <sup>+++</sup> sorption of SIP, g P/m <sup>3</sup>	khfe	0.25	Calibrated,8
Rate for RFESIP, 1/h	knap	0.001	Calibrated,2
Halfsat. conc. for EC uptake of SIP, g P/m <sup>3</sup>	ksep	0.05	
Diffusion of IN, SNH and SNO <sub>3</sub> in sediment, m <sup>2</sup> /h	difn	0.0000096	1,17
Teta temp dependency of denitrification	tde	1.087	Calibrated,10

\*) References

- 1) Lomstein 1995, 2) Ruadij 1995, 5) Mortensen 1992, 6) Jensen 1995, 7) Jacobsen 1978, 8) Jacobsen 1977, 9) Gundresen 1995, 10) Windolf 1996, 11) Bocci 1997, 12) Coffaro 1997, 13) Iziumi 1982, 15) Blackburn 1983, 17) Sweerts 1991



## 6 Future Developments

Future versions of MIKE 21/3 EU will provide the possibility of including modules for filtrators (mussels etc.), feed-back from sediment spills. Also a flexible ecosystem description that can be defined and edited by the user will be developed.



## 7 Solution Technique

The solution of the set of ordinary coupled differential equations is found using an integration routine in an integrated two-step procedure with the AD module.

The results give a resolution in space and time depending on the details of the chosen grid and the time step used.





## 8 Data Requirements

- Basic Model Parameters
  - Model grid size and extent
  - Time step and length of simulation
  - Type of output required and its frequency
- Bathymetry and Hydrodynamic Input
- Combined Advection-Dispersion Model
  - Dispersion coefficients
- Initial Conditions
  - Concentration of parameters
- Boundary Conditions
  - Concentration of parameters
- Pollution Sources
  - Discharge magnitudes and concentration of parameters
- Process Rates
  - Size of coefficients governing the process rates. Some of these coefficients can be determined by calibration. Others will be based on literature values or found from actual measurements and laboratory tests.



## 9 List of References

- /1/ Bach, H.K., D. Orhon, O.K. Jensen & I.S. Hansen. *Environmental Model studies for the Istanbul Master Plan. Part II: Water Quality and Eutrophication*. Wat.Sci.Tech. Vol. 32, No. 2, pp 149-158, 1995.
- /2/ Bach, H., A. Malmgren-Hansen and J. Birklund. *Modelling of Eutrophication Effects on Coastal Ecosystems with Eelgrass as the Dominating Macrophyte*. Presented at the Int. Conf. on Marine Coastal Eutrophication, Bologna, 21-23 March 1990.
- /3/ Baker, E.T. and J.W. Lavelle. *The Effect of Particle Size on the Light Attenuation Coefficient of Natural Suspensions*. J. of Geophysical Reas. Vol. 89, No. C5, pp 8197-8203, Sept. 1984.
- /4/ Blackburn T.H., Henriksen K. Nitrogen cycling in different types of sediments from Danish Waters Limnol. Oceanogr. 28(3), pp. 477-493.
- /5/ Bocci M., Coffaro G., Bendoricchio G. Modelling biomass and nutrient dynamics in eelgrass (*Zostera marina*): applications to Lagoon of Venice (Italy) and Øresund (Denmark) Ecol. Model. 102, pp 67-80, 1997.
- /6/ Canale, R.P. and Martin T. Aues. *Ecological Studies and Mathematical Modelling of Cladophora in Lake Huron: 5. Model Development and Calibration*. J. Great Lakes Res. 8(1), pp 112-125, 1982.
- /7/ Coffaro G., Bocci M. 1997. Resources competition between *Ulva rigida* and *Zostera marina*: a quantitative approach applied to the Lagoon of Venice. Ecol. Model. 102 PP 81-95, 1997
- /8/ Dahl-Madsen, K.I. *Mathematical Modelling of Eutrophied Coastal Areas*. Prog. Wat. Tech., Vol. 10, Nos. 5/6, pp 217-235, 1978.
- /9/ Droop, M.R. *Some thoughts on nutrient limitation in algae*. J. Phycol. 9: 264-272, 1973.
- /10/ Droop, M.R. *The nutrient status of algal cells in batch cultures*. J. Mar. Biol. Ass. U.K. 55: 541-555, 1975.
- /11/ Goldman, Joel C. *Outdoor Algal Mass Cultures- II Photosynthetic Yield Limitations*. Water Research, Vol. 13, pp 119-136, 1979.
- /12/ Gordon, D.M., P.B. Birch and A.J. McComb. *The effect of light, temperature, and salinity on photosynthetic rates of an estuarine Cladophora*. Bot. Mar. 23: 749-755, 1980.
- /13/ Gundresen K.J., Glud R.N., Jørgensen B.B. Havbundens Iltomsætning. Havforskning fra Miljøstyrelsen, nr. 57. 1995
- /14/ Hobson, L.A. *Effects of interaction of irradiance, daylength, and temperature on division rates of three species of marine unicellular algae* J. Fish. Res. Bd. Canada 31: 391-395, 1974.
- /15/ Horwood, J.W. *A model of primary and secondary production*. ICES C.M. 1974/L 19:1-10, 1974.

- /16/ Ichimura, S. *Environmental gradient and its relation to primary productivity in Tokyo Bay*. Records Oceanogr. Works (Japan) 9: 115-128, 1967.
- /17/ Iziumi H., Hattori A. Growth and organic production of eelgrass (*Zostera marina*) in temperate waters of the pacific coast of Japan. III The kinetics of nitrogen uptake. Aquat. Bot. 12, pp. 245-256, 1982.
- /18/ Jacobsen O.S. Sorption, adsorption and chemisorption of phosphate by Danish lake sediments Vatten nr. 4, PP 230-241, 1978
- /19/ Jacobsen O.S. Sorption of phosphate by Danish Lake Sediments Vatten nr. 3, PP 290-298, 1977.
- /20/ Jassby, A.D. and C.R. Goldman. *Loss rates from a lake phytoplankton community*. Limnol. Oceanogr. 21: 540-547, 1974.
- /21/ Jensen H.S., Mortensen P.B., Andersen F.Ø, Rasmussen E.K., A. Jensen, 1995. Phosphorus cycling in coastal marine sediment. Limnol. Oceanogr. 40(5), PP 908-917.1995.
- /22/ Lancelot, C. and V. Rousseau. *ICES intercalibration exercise on the 14C method for estimating phytoplankton primary production. Phase 2: experiments conducted on board of RV DANA*. Preliminary report, 35 pp, 1987.
- /23/ Lancelot, C, G. Billen, A. Sourina, T. Weisse, F. Colijn, M.J.W. Veldhuis, A. Davies and P. Wassman. *Phaeocystis blooms and nutrient enrichment in the continental coastal zones of the North Sea*. Ambio 16: 38-46, 1987.
- /24/ Lomstein, Bente et al. Omsætning af organisk kvælstof i marine sedimenter. Havforskning fra Miljøstyrelsen nr. 58. 1995
- /25/ Mommaerts, J.P. *Systeembenadering van en gesloten mariene milieu, met de nadruk op de rol van het fytoplankton*. Doctoral thesis. Vrije Universiteit Brussel: 1-335, 1978.
- /26/ Mortensen P.B., Jensen H.S., Rasmussen E.K., Østergaard Andersen P. Fosforomsætning i sedimentet i Århus Bugt. Havforskning fra Miljøstyrelsen, nr. 17. 1992.
- /27/ Nyholm, Niels. *A Mathematical Model for the Growth of Phytoplankton*. Presented at the Int. Symp. on Experimental Use of Algal Cultures in Limnology, Sandefjord, Norway, Oct. 26-28 1976.
- /28/ Nyholm, N. *Kinetics of phosphate-limited algal growth*. Biotechn. Bioengineering 19: 467-492, 1977.
- /29/ Nyholm, Niels. *A Simulation Model for Phytoplankton Growth Cycling in Eutrophic Shallow Lakes*. Ecological Modelling, Vol. 4, pp 279-310, 1978.
- /30/ Nyholm, Niels. *The Use of Management Models for Lakes at the Water Quality Institute, Denmark*. State-of-the-art in Ecological Modelling, Vol. 7, pp 561-577, 1979.
- /31/ Press, W.H., B.P. Flannery, S.A. Teukolsky and W.T. Vetterling. *Numerical Recipes*. Cambridge University Press (1986). Press.

- /32/ Ruadij P., W. Van Raaphorst, 1995 Benthic nutrient regeneration in the ERSEM ecosystem model of the North Sea Netherlands Journal of Sea Research, 33 (3/4) PP 453-483, 1995
- /33/ Scavia, Donald. *Examination of Phosphorus Cycling and Control of Phytoplankton Dynamics in Lake Ontario with an Ecological Model*. J. Fish. Res. Board Can., Vol. 36, pp 1336-1346, 1979.
- /34/ Schnorr, J.L. and D.M. Di Toro. *Differential Phytoplankton Sinking- and Growth Rates: an Eigenvalue Analysis*. Ecological Modelling, Vol. 9, pp 233-245, 1979.
- /35/ Smayda, T.J. *The suspension and sinking of phytoplankton in the sea*. Oceanogr. Mar. Biol. Ann. Rev. 8: 357-414, 1970.
- /36/ Steele, J.H. *The role of predation in ecosystem models*. Mar. Biol. 35: 9-11, 1976.
- /37/ Steemann Nielsen, E. and E.G. Jørgensen. *The adaptation of plankton algae. III. With special consideration of the importance in nature*. Physiol. Plant. 21: 647-654, 1968.
- /38/ Swartzman, Gordon L., and Richard Bentley. *A Review and Comparison of Plankton Simulation Models*. ISEM Journal 1, Nos. 1-2, pp 30-81, 1979.
- /39/ Sweerts et al. Similarity of whole-sediment molecular diffusion coefficients in fresh water sediments of low and high porosity. Limnol. Oceanogr. 36 (2), pp. 336-341, 1991.
- /40/ Tett, P., A. Edwards and K. Jones. *A model for the growth of shelf-sea phytoplankton in summer*. Estuar. Coast. Shelf Sci. 23: 641-672, 1986.
- /41/ Valiela, I. *Marine ecological processes*. ISBN 3-540-90929-X, Springer-Verlag, New York, 1984.
- /42/ Wetzel, R.L., R.F. van Tine and P.A. Penhale. *Light and Submerged Macrophyte Communities in Chesapeake Bay: A Scientific Summary*. Report of the Chesapeake Bay Programme, Virginia Institute of Marine Science, 1981.
- /43/ Sundby Bjørn, Gobeil C., Silverberg N. The Phosphorus cycle in coastal marine sediments. Limnol. Oceanogr. 37 (6), pp. 1129-1145. 1992.
- /44/ Williams, P.J. LEB. *Aspects of dissolved organic material in sea water*. In: J.P. Riley & G. Skirrow. Chemical Oceanography. Academic Press, New York: 301-363, 1975.
- /45/ Windolf J, Jeppesen E., Jensen J.P. Kristensen P. 1996. *Modelling of seasonal variation in nitrogen retention and in-lake concentration: A four-year mass balance study in 16 shallow Danish Lakes*. Biogeochemistry 33, PP 25-44. 1996

