

MIKE 21C

Curvilinear Model for River Morphology

User Guide



PLEASE NOTE

COPYRIGHT

This document refers to proprietary computer software which is protected by copyright. All rights are reserved. Copying or other reproduction of this manual or the related programs is prohibited without prior written consent of DHI. For details please refer to your 'DHI Software Licence Agreement'.

LIMITED LIABILITY

The liability of DHI is limited as specified in Section III of your 'DHI Software Licence Agreement':

'IN NO EVENT SHALL DHI OR ITS REPRESENTATIVES (AGENTS AND SUPPLIERS) BE LIABLE FOR ANY DAMAGES WHATSOEVER INCLUDING, WITHOUT LIMITATION, SPECIAL, INDIRECT, INCIDENTAL OR CONSEQUENTIAL DAMAGES OR DAMAGES FOR LOSS OF BUSINESS PROFITS OR SAVINGS, BUSINESS INTERRUPTION, LOSS OF BUSINESS INFORMATION OR OTHER PECUNIARY LOSS ARISING OUT OF THE USE OF OR THE INABILITY TO USE THIS DHI SOFTWARE PRODUCT, EVEN IF DHI HAS BEEN ADVISED OF THE POSSIBILITY OF SUCH DAMAGES. THIS LIMITATION SHALL APPLY TO CLAIMS OF PERSONAL INJURY TO THE EXTENT PERMITTED BY LAW. SOME COUNTRIES OR STATES DO NOT ALLOW THE EXCLUSION OR LIMITATION OF LIABILITY FOR CONSEQUENTIAL, SPECIAL, INDIRECT, INCIDENTAL DAMAGES AND, ACCORDINGLY, SOME PORTIONS OF THESE LIMITATIONS MAY NOT APPLY TO YOU. BY YOUR OPENING OF THIS SEALED PACKAGE OR INSTALLING OR USING THE SOFTWARE, YOU HAVE ACCEPTED THAT THE ABOVE LIMITATIONS OR THE MAXIMUM LEGALLY APPLICABLE SUBSET OF THESE LIMITATIONS APPLY TO YOUR PURCHASE OF THIS SOFTWARE.'





CONTENTS

1	Introduction	11
1.1	General Description of MIKE 21C	11
1.2	Areas of Application	12
2	Basic Parameters	13
2.1	Module Selection	13
2.2	Bathymetry	13
2.3	Simulation Period	14
2.4	Boundary	14
2.5	Sources and Sinks	14
2.6	Flood and Dry	15
3	Hydrodynamic Parameters	17
3.1	Initial Surface Elevation	17
3.2	Boundary (HD)	17
3.3	Sources and Sinks (HD)	18
3.4	Eddy Viscosity	19
3.5	Resistance	19
3.6	Fluid Properties	19
3.7	HD Integration	20
3.7.1	Fully dynamic	20
3.7.2	Scaled dynamic	20
3.7.3	Quasi-steady	21
3.7.4	Steady	22
3.8	Structures	22
3.8.1	Weirs	22
3.8.2	Culverts	25
3.8.3	Dikes	28
3.8.4	Composite structures	31
3.8.5	Level-width relationship	31
3.8.6	Remarks and hints	32
3.9	Results (HD)	34
3.9.1	Results files	34
3.9.2	Hotstart files	35
4	River Morphology Parameters	37
4.1	Starting Conditions	37
4.1.1	Simulation period	37
4.1.2	Sub-modules	38



4.1.3	Morphological time-step	38
4.1.4	Morphological drying depth	38
4.1.5	Implicit AD solver	39
4.1.6	Log output	39
4.2	Helical Flow	41
4.3	Sediment Transport	41
4.3.1	Bed slope effect	42
4.3.2	Fall velocity modification	42
4.3.3	Maximum concentration allowed due to erosion	43
4.3.4	Grain size	43
4.3.5	Initial concentrations	43
4.3.6	Dispersion coefficient	44
4.3.7	Transport theory	44
4.4	Planform	45
4.4.1	Bank erosion	45
4.4.2	Curvilinear grid	46
4.4.3	Specification for bank lines	47
4.5	Alluvial Resistance	47
4.6	Morphological Update	48
4.6.1	Equilibrium layer thickness	48
4.6.2	Morphological update	49
4.7	Layer Thickness	51
4.8	Component Percentage	51
4.9	Boundary (ST)	51
4.10	Results (ST)	52
4.10.1	Output areas	52
4.10.2	Save properties	53
5	Reference Manual	55
5.1	Adaption Lengths	55
5.1.1	General	55
5.1.2	Main flow adaptation	56
5.1.3	Bed deformation adaptation	57
5.1.4	Concentration adaptation	57
5.1.5	Oscillations in bed deformations	58
5.1.6	Hints	59
5.2	Alluvial Resistance	59
5.3	Bank Erosion	59
5.3.1	Graded sediment	61
5.3.2	River bed update	61
5.3.3	Bank line update	61
5.4	Bed Load	61
5.5	Bed Resistance	62
5.6	Bed Slope	63
5.6.1	Hints	65
5.7	Bottom Update	66
5.7.1	Bathymetry	67



5.7.2	Bed resistance	67
5.8	Boundary Conditions	68
5.8.1	General description	68
5.8.2	Sediment transport	69
5.8.3	Bed level change	70
5.8.4	Hints	71
5.9	Curvilinear Grid	71
5.10	Dispersion Coefficients	74
5.10.1	General	74
5.10.2	Specifying the dispersion coefficients	74
5.10.3	Recommended selection and values	74
5.10.4	Hints	75
5.11	Graded Sediment Model	75
5.11.1	Hints	78
5.12	HD Integration	78
5.13	Helical Flow	79
5.13.1	Theoretical background	80
5.13.2	Recommended value	82
5.13.3	Hints	82
5.14	Hot Start	82
5.14.1	General	82
5.14.2	Hydrodynamics	82
5.14.3	Sediment transport	83
5.14.4	Morphological model	83
5.14.5	Hints	83
5.15	Hydrodynamics	83
5.16	Initial Conditions	84
5.16.1	General	84
5.16.2	Helical flow	84
5.16.3	Sediment transport	85
5.17	Long-Term Simulations	85
5.17.1	Scaled dynamic	85
5.17.2	Scaling factor	86
5.18	Model Specification File	86
5.19	Morphological Control Parameters	87
5.20	Mud, Debris or Oil	87
5.20.1	Recommended values	88
5.21	Optional Parameters	90
5.21.1	Hydrodynamic optional parameters	91
5.21.2	Morphological optional parameters	91
5.22	Profile Functions	92
5.23	Quasi Steady Solver Control	93
5.24	Scaling Factor	95
5.25	Sediment Characteristics	95
5.25.1	Sediment transport	95
5.25.2	Grain size	96



5.25.3	Fall velocity	97
5.25.4	Porosity	98
5.25.5	Sediment density	98
5.26	Sediment Formulae	98
5.27	Sediment Transport Model Time-Step Selection	99
5.28	Simulation Time	99
5.29	Space Step Selection	100
5.30	Structures	100
5.30.1	Location of a structure	100
5.30.2	Weirs	102
5.30.3	Culverts	105
5.30.4	Dikes	108
5.30.5	Flow directions for specific structure parameters	109
5.30.6	Remarks and hints	109
5.31	Suspended Load	110
5.32	Time-Step Selection	112
5.32.1	General	112
5.32.2	Quasi-steady approach	113
5.32.3	Hints	113
5.33	Update Computational Grid	114
5.34	References	116
6	Examples	121
6.1	Morphological Model of a Meandering Stream	121
6.1.1	Introduction	121
6.1.2	Before starting this tutorial	121
6.1.3	Problem definition	121
6.1.4	Model bathymetry	122
6.1.5	Hydrodynamic simulation	122
6.1.6	Morphological simulation	125
6.1.7	Going further	131
6.2	Morphological Model of a Trench	132
6.2.1	Introduction	132
6.2.2	Before starting this tutorial	133
6.2.3	Problem definition	133
6.2.4	Model bathymetry	134
6.2.5	Hydrodynamic simulation - hot start	135
6.2.6	Hydrodynamic simulation - scaled dynamic HD solution	139
6.2.7	Sediment transport simulation	140
6.2.8	Morphological simulation	143
6.2.9	Going further	144
6.3	Morphological Model of a U-Flume	149
6.3.1	Introduction	149
6.3.2	Before starting this tutorial	149
6.3.3	Problem definition	149
6.3.4	Model bathymetry	150
6.3.5	Hydrodynamic hot start simulation	150
6.3.6	Simulation of helical flow	156



6.3.7	Results	160
6.3.8	Simulation of bed load, suspended load and morphology	162
6.3.9	Results	168
6.3.10	Further analysis	171
6.4	Hydrodynamic Modelling of Retention Basin	173
6.4.1	Introduction	173
6.4.2	Problem definition	174
6.4.3	Model bathymetry	174
6.4.4	Hydrodynamic conditions	175
6.4.5	Simulating overflow of river bank	176
6.4.6	Simulating emptying of retention basin	177
6.4.7	Simulating failure of river bank	178
6.4.8	List of data and specification files	180
7	MIKE 21C Utilities	181
7.1	Curvilinear Discharge Calculation	181
7.1.1	General description	181
7.1.2	Input data	182
7.1.3	Specifications	182
7.2	Result Viewer	182
7.2.1	Opening result files	182
7.2.2	Formatting the view	183
7.2.3	Changing the work area	183
7.2.4	Creating animations	184
7.2.5	Extracting time series	184
7.2.6	Saving time series to files	184
7.2.7	Import external data files into plots	184
Index		185





1 Introduction

1.1 General Description of MIKE 21C

MIKE 21C is a special module of the MIKE 21 software package based on a curvilinear (boundary-fitted) grid, which makes it suitable for detailed simulation of rivers and channels, where an accurate description of bank lines is required. The numerical grid is created by means of a userfriendly grid generator. Areas of special interest can be resolved using a higher density of grid lines at these locations. The MIKE 21C is particularly suited for river morphological studies and includes modules to describe:

- Flow hydrodynamics, i.e. water levels and flow velocities are computed over a curvilinear or a rectangular computational grid covering the study area by solving the vertically integrated St. Venant equations of continuity and conservation of momentum.
- Helical flow (secondary currents) which is developing in channel bends due to curved streamlines is included. The time and space lag in the development of the helical flow is also described.
- Sediment transport, based on various model types (e.g. van Rijn, Meyer-Peter&Müller, Engelund-Hansen, Engelund-Fredsoe, Yang, or user-defined empirical formulas). The effect of helical flow, gravity on a sloping river bed, shapes of velocity and concentration profiles are taken into account in separate bed load and suspended load sub-models based on the theories by Galappatti. Graded sediment descriptions can be applied as well by defining a number of different sediment fractions, which are treated separately by the sediment transport module.
- Alluvial resistance due to bed material and bed forms (calculation of skin friction from the grain sizes and form drag friction from the bed forms).
- Scour and Deposition: Large-scale movement of bed material is computed. The continuity equation for sediment is solved for determining changes in bed elevations at each grid cell at every time-step. The effect of supply limited sediment layers can be incorporated as well. This is used for simulating for instance downstream migration of fine material on a coarse riverbed, or for representing non-erodible (protected) riverbed areas in the modelling domain.
- Bank erosion and plan form changes: The bank erosion is computed from a formula relating near-bank conditions to bank erosion rates. The accumulated bank erosion can be used for updating the bank lines, and for updating the curvilinear grid (extent of the modelling area) at every time-step. By defining a silt factor, the bank erosion products can be included in the sediment budget for the adjacent riverbed, or it can be disregarded depending on the composition of the bank material.



The modules can run interactively, incorporating feedback from variations in the alluvial resistance, bed topography and bank line geometry to the flow hydrodynamics and sediment transport.

1.2 Areas of Application

MIKE 21C is applied for a variety of model applications which include river hydraulics and/or sediment transport. Few examples from projects carried out in the past are:

- Flow field and flood studies of river channels and adjacent floodplains. A curvilinear grid allows a coarser resolution of the channel because the grid lines follow the bank lines. A 2D river model can therefore cover for instance 100-150 km.
- Forecast of morphological changes over 2-3 years in a highly mobile braided river in connection with planning and execution of river training works.
- Preparation of design criteria for river training works in terms of flow velocities, flow depths, scour depths, bank line retreat rates, shoaling, etc.
- Prediction of induced plan form changes including land erosion and enhanced flooding of floodplains due to river crossings (e.g. bridges)
- Analysis of sediment deposition (and erosion) near water intakes, offtakes, bifurcations, confluences, harbour entrances, etc.
- Design of optimum alignment of navigation channels, and prediction of required annual maintenance dredging.
- Reservoir sedimentation



2 Basic Parameters

Specify the basic parameters for your MIKE 21C Curvilinear Model simulation.

Selections made here determine the structure of the setup editor, such as the required entries for the hydrodynamic module and possible add-on modules. The tree-view and the number of available dialogues will expand according to the basic parameters selected.

2.1 Module Selection

You can choose between the following modules:

- hydrodynamics only (see Hydrodynamic Parameters)
- hydrodynamics and river morphology (see River Morphology Parameters)

You can choose to apply an alternative hydrodynamic solution for simulation of fluids with a different flow behaviour than clear-water if you activate the 'Mud, Debris or Oil' option.

Notice: Activating the Mud, Debris or Oil option will automatically introduce an additional 'Fluid Properties' page in the Hydrodynamic Parameters section of the Editor.

2.2 Bathymetry

You can start a simulation in two ways:

- as a cold start
- as a hot start

For a cold start the velocity field is initialised to zero. Specify a type 2 data file containing the bathymetry.

The curvilinear grid description requires 2 files:

- a type 2 data file containing bathymetry information - enter this file name under the 'Bathymetry' field
- a type 2 data file containing grid information - enter this file name under the 'Grid' field

The hot start facility requires a hot file, which must have been created by a previous simulation. Hot start files contain all the necessary information to continue a simulation. This method can reduce overall simulation times, if for



example a number of scenarios are to be simulated, all based on the same (hot start) initial conditions.

Finally, a tick is required to indicate that a curvilinear grid is to be used. If not ticked, the model will behave as a rectilinear model.

2.3 Simulation Period

- In this dialogue you must specify simulation period information:
- Time-step range is the number of time-steps the simulation should cover.
- The time-step interval is the period of time incremented between each time-step. In case of a hot-started simulation, the time-step is taken from the hot file and cannot be changed unless it is changed in the hot-start file itself by changing the data utility parameters.
- The simulation start date is the historical date and time corresponding to time-step zero. In case of a hot-started simulation, the simulation start date is read from the hot file and cannot be changed unless it is changed in the hot-start file itself by changing the data utility parameters.
- The warm-up period is a number of time-steps over which the forcing functions are gradually increased from zero to 100% of their true value.

For information and as a possible check on parameter specifications, the simulation end date (and hour) is calculated and shown in the dialogue.

2.4 Boundary

The model requires either a water level or a discharge at all open boundaries.

When a bathymetry or a 'hot start' file for the main area has been specified under 'Bathymetry', it is scanned to find the open boundaries, i.e. they are 'program detected'.

Usually these boundary positions are applied 'as is', but can also be defined explicitly. The reasons for doing this may include internal boundaries or a boundary stretching over a series of small islands. For such 'user specified' boundaries, specify the number of open boundaries and their locations in terms of first and last (end) points. A maximum of 32 open boundaries is allowed.

2.5 Sources and Sinks

The model distinguishes between three different kinds of sources/sinks:



1. Isolated source
Water is discharged into the model at a given velocity. Both continuity and momentum equations are affected.
2. Isolated sink
Water is discharged (sucked) from the model. Only the continuity equation is affected.
3. Connected source and sink pair
The amount of water removed at the sink point is reentered at the source point, with a specified velocity.

Up to 256 sources and sinks can be specified in a single model. Source and sink positions are defined with horizontal (j,k) grid coordinates.

Do not place sources or sinks on land or at locations that may occasionally dry out.

2.6 Flood and Dry

Flooding and drying is required if initially dry regions of the model become inundated, or if initially wet regions become dry.

Set the minimum water depth allowed in a point before it is removed from calculations (drying depth), and the water depth at which the point will be reentered into the calculation (flooding depth).



Note: Morphological models always require flood and dry activated.





3 Hydrodynamic Parameters

The MIKE 21C hydrodynamic (HD) module calculates the hydrodynamic behaviour of water in response to a variety of forcing functions, such as prescribed water levels or flows at open model boundaries. The following HD related parameters are specified:

- Initial Surface Elevation
- Boundary (HD)
- Sources and Sinks (HD)
- Eddy Viscosity
- Resistance
- Fluid Properties
- HD Integration
- Structures
- Results (HD)

A more in-depth description is given in the HD Reference Manual (p. 55).

3.1 Initial Surface Elevation

Having selected a cold start simulation under Bathymetry, you must also provide information about the initial (water) surface level. The initial surface elevation for each area can be specified in two ways:

- as a constant value, or
- read from a 2D (type 2) data file.

The initial surface level can usually be set to a constant value applied over the whole model area. However, specify values that agree with your boundary conditions, i.e. if you start a simulation at high water with a boundary value of 0.5 m you should also specify the initial surface elevation to 0.5 m. for long models initial maps with a linear variation of the surface deviation from upstream to downstream is applied.

For hot-starts, all initial conditions - including the surface elevations - are read from the hot-file.

3.2 Boundary (HD)

The HD model requires either water levels or discharges at all open boundary points specified in the Boundary menu. Note that flux is defined as the total discharge passing the open boundary. The total discharge is automatically distributed along the open boundary based on a Manning description. Actual values, level or flux, can be specified at each boundary in several different formats:



- **Constant value**
Specify a constant both in space and time, applied along the whole boundary.
- **Sine series**
Specify the reference level, range, period and phase of the sine series.
- **Time series**
Specify the name of a type 0 data file. The temporal variation given in this file is applied along the whole boundary.
- **Line series**
The temporal variation along the boundary is obtained from the specified type 1 data file.
- **Transfer data**
For transfer data, boundary values are obtained from the results of another simulation, i.e. from a transfer data file generated by the 'Transfer boundary tool', M21trn, in the MIKE 21 Toolbox.
- **Rating curve**
In case of rating curve you must specify a dfs0 file representing the relation between discharge and water level (specified by relative axis). The use of Rating curve is only recommended for downstream boundaries where water flows out of the model.

The FAB type determines the strategy for calculating fluxes along the open boundary. See the manual for a description and discussion of available options.

Default flow directions are perpendicular to the open boundary. In situations where this can not be assumed, the possibility exists for specifying the directions.

See also Boundary Conditions (*p. 68*).

3.3 Sources and Sinks (HD)

For each source the discharge characteristics are required:

- discharge magnitude
- speed
- outlet direction

For each sink the following is required:

- the intake magnitude



Sources contribute to both the momentum and continuity equations, while the sink only contributes to the continuity equation. For a connected source-sink pair, discharge magnitude at the source equals the intake magnitude at the sink.

Source/sink magnitudes and source speed can be given either in a type 0 file (time series) or as constant values. Outlet direction is horizontal relative to true North and should be specified as a constant.

3.4 Eddy Viscosity

Eddy viscosity can be specified in several ways:

1. Eddy terms are omitted (no eddy viscosity)
2. Constant value specified
3. Read from a type 2 data file, with each grid point assigned its own eddy viscosity value
4. Dynamically calculated using the Smagorinsky formula

When using the Smagorinsky formulation a proportionality factor is required. The option is available to use either velocity or flux based eddy viscosity formulations. For river applications the flux based eddy viscosity formulation should be avoided.

3.5 Resistance

Bottom friction can be specified in two ways:

- a constant value
- a type 2 data file where each grid point has a defined friction value

Values can be specified as Chezy or Manning numbers; the same type of number for all areas throughout the model. Manning numbers are converted to Chezy numbers on the basis of the calculated water depth.

Specify a constant value or a type 2 data file name.

3.6 Fluid Properties

The Fluid Description page becomes visible in the Flow Model editor when activating the 'Mud, Debris or Oil' option in the Module Selection page.

Fluid properties include the specification of values for key variables for an alternative hydrodynamic solution targeting single-phase fluid of different flow characteristics than clean-water. A flow resistance relationship for a flow



regime equivalent to a Bingham or Non-Newtonian flow approach is calculated under the assumption that the debris-flow material behaves like a viscoplastic fluid. Fluids considered for this solution would typically be oil or debris flow with high concentrated mixtures of flowing sediments and water.

Fluid property parameters to be defined include: Fluid Density, Yield stress and Bingham fluid viscosity.

Remarks and hints

The Bingham fluid viscosity must be defined as a Dynamic viscosity.

When a Bingham formulation is activated and a resistance relation is calculated from this, the turbulent resistance (Bed resistance) defined by Manning or Chezy values should ideally be deactivated. However, in situations where Yield/Bingham stresses are not dominating, turbulent resistance may be crucial to maintain model stability, and hence, it is important to realize that turbulent resistance and the resistance relation from the Bingham solution are both active and included as individual resistance contributions in the hydrodynamic solution.

See also Mud, Debris or Oil (*p. 87*).

3.7 HD Integration

Modifications to the solution scheme can be made in this dialogue.

The top left box contains the General time-step as information. Below this, the Integration Type is specified:

- Fully dynamic
- Scaled dynamic
- Quasi-steady
- Steady

3.7.1 Fully dynamic

The HD simulation will perform a fully dynamic simulation (default).

3.7.2 Scaled dynamic

The simulation will be performed with the HD time-step different to the General time-step. The scale factor between the HD and General time-steps for the simulation is shown as information.



3.7.3 Quasi-steady

A quasi steady simulation uses parameters provided in the top-right and bottom-right boxes:

- Momentum - Time-step: The time-step for the solution of the dynamic momentum equations.
- Momentum - Parameter: A relaxation parameter for the selected equation solver. Values of 1 - 1.5 (1.2 is recommended) are typically used for Line SOR solver, and 0 - 1 (0.8 is recommended) for the SSIP solver.
- Momentum - Stop criterion: This is the stop criterion used for the momentum equations. Typical values are of the order of 10^{-8} - 10^{-6} .
- Momentum - Max Iterations: The maximum number of iterations used for the momentum equations. At least 4 iterations of the momentum equations are recommended to ensure convergence.
- Momentum - Solver: Choice of solver for the momentum equation. The Line SOR solver is typically applied as the equation is convection dominated. An alternative solver is the SSIP (Stone's Strongly Implicit Procedure, Stone 1968).
- Pressure - Time-step: The time-step for the solution of the continuity equation.
- Pressure - Parameter: A relaxation parameter for the selected equation solver (same as for the momentum equation).
- Pressure - Stop criterion: This is the stop criterion used for the momentum equations (same as for the momentum equation).
- Pressure - Max Iterations: The maximum number of iterations used for the pressure equation. At least 10 iterations of the pressure equation are recommended to ensure convergence.
- Pressure - Solver: Choice of solver for the continuity equation. The SSIP (Stone's Strongly Implicit Procedure) is typically applied as the equation is fully elliptic, although the Line SOR method is also available.

The quasi-steady HD solver is good for steady flow situations and situations with slowly varying boundary conditions. The solver allows different time-steps in the momentum and continuity equations, but this should be avoided when the flow solution varies in time. The quasi-steady solver is also not suited for situations with significant flooding and drying, e.g. floodplain flows.

3.7.4 Steady

A steady-state approach uses the HD solution stored in the hotstart file for all hydrodynamic calculations.

For more information on the use of these parameters, see the Reference Manual and Scientific Documentation.

3.8 Structures

Three types of hydraulic structures are presently available. These are:

- Weirs
- Culverts
- Dikes

Furthermore you have the option to include Composite structures by combining a weir and one or several culverts.

3.8.1 Weirs

Weir data are defined in two grid tables in the present page: Upper input data grid and Lower input data grid.

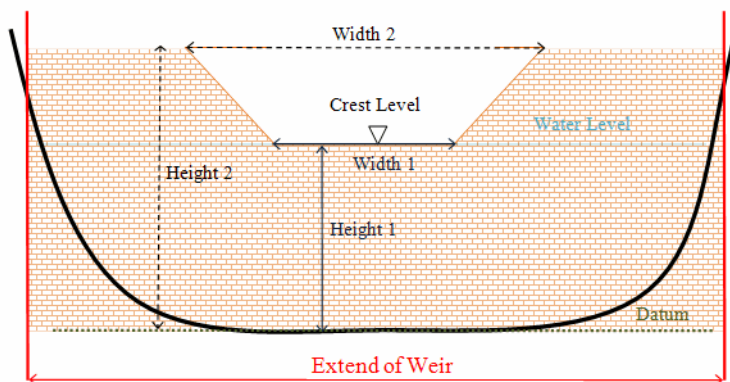

Figure 3.1 Setup definitions of contracted weir

Upper input data grid

The number of weirs must be defined initially. This number defines the number of structure definition lines which will be present for defining weir input data.



Name

The Name of weir is a user defined ID-string for each weir

Note: Names must not be identical for different structures included in the model simulations.

Location

'Location' and 'Projection' columns define the actual location of the weir.

Weirs are defined in the model area as a cross section specified as a list of points (a minimum of two points required), through which the structure flow occurs. The weir section is composed of a sequence of straight line segments between successive points, where the geographical coordinates are defined in the 'point selection' dialogue, which opens when pressing the button in the 'Location' column. You must also select the map projection (Longitude/Latitude, UTM etc.) in which the specified location coordinates for the weir are defined.

See also Location of a structure (*p. 100*).

Type

The weir-formula to be applied is selected from the drop down selection list in the 'Type' column. A range of formulas are available:

- Broad crested weir
- Weir formula 1
- Weir formula 2 (Honma formula)

Valve

- Valve regulation of the structure flow can be defined as part of the weir definition. Four different valve regulation types are available:
 - **None**
No valve regulation applies (flow is not regulated).
 - **Only Positive Flow**
Only flow in positive flow direction is allowed. Valve regulation does not allow flow in negative flow direction and the flow through the structure will be zero in this case.
 - **Only Negative Flow**
Only flow in negative flow direction is allowed. Valve regulation does not allow flow in positive flow direction and the flow through the structure will be zero in this case.
 - **No Flow**
No flow is allowed in the structure. Valve regulation closes completely the structure.



See also Flow directions for specific structure parameters (*p. 109*).

Alpha zero

When the water level gradient across a structure is small the corresponding gradient of the discharge with respect to the water levels is large. This in turn may result in a very rapid flow response to minor changes in the water level upstream and downstream. As a way of controlling this effect a Alpha Zero factor has been introduced. The Alpha Zero factor defines the water level difference below which the discharge gradients are suppressed. The default setting is 0.01 meter. If a structure shows oscillatory behaviour it is recommended to increase this value slightly.

Head loss factors

The Loss Factors determines the energy (Head) loss of the flow over the weir. These are defined in the last six columns. Each loss factor is defined by a suffix, where '+' indicates Positive Flow direction and; suffix '-' indicates Negative Flow direction. (e.g. 'Inflow -' means inflow loss coefficient for negative flow direction).

Three types of Loss factors are present for both positive and negative flow direction:

- Inflow (contraction loss)
- Outflow (expansion loss)
- Free flow

Head Loss Factors are applied in structure flow calculation only for the broad crested weir type. See also Head loss factors (*p. 104*).

Lower input data grid

The lower input data grid contains the geometry definition for the broad crested weir type or alternatively values of weir formula parameters if one of the weir formulas have been selected.

For the Broad crested weir formula the geometrical shape of the active flow area must be defined by a Level-width relationship table. The levels are defined relative to the datum (starting from the crest or sill level and up). E.g. for a horizontal weir positioned at invert level -10m (bed level) and extending 6 m above the bed, the weir could should be defined by $L_0 = -4\text{m}$ and $L_1 = 0\text{m}$. Datum defines an offset which is added to the level column in the level/width table during computation.

Pressing the button in the 'Location' column button in the 'Geometry' column opens a Level-Width dialogue where the geometry relation can be entered. '



For Weir formula 1 and Weir formula 2 the geometry of the structure itself must be defined. From this the active flow area will be calculated automatically in the simulation. Values for the respective weir formula parameters must be defined in the respective columns.

See also Weirs (p. 102).

3.8.2 Culverts

Culvert data are defined in two grid tables in the present page: Upper input data grid and Lower input data grid.

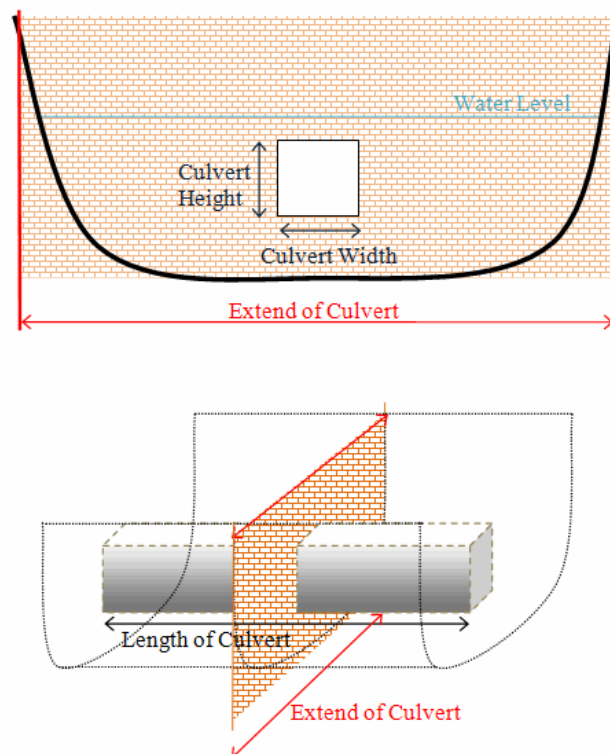

Figure 3.2 Setup definitions of culvert

Upper input data grid

The number of culverts must be defined initially. This number defines the number of structure definition lines which will be present for defining culvert input data.

Name

The Name of culvert is a user defined ID-string for each culvert.



Note: Names must not be identical for different structures included in the model simulations.

Location

'Location' and 'Projection' columns define the actual location of the culvert.

Culverts are defined in the model area as a cross section specified as a list of points (a minimum of two points required) through which the structure flow occurs. The culvert section is composed of a sequence of straight line segments between successive points, where the geographical coordinates are defined in the 'point selection' dialogue, which opens when pressing the  button in the 'Location' column. You must also select the map projection (Longitude/Latitude, UTM etc.) in which the specified location coordinates for the culvert are defined.

See also Location of a structure (*p. 100*).

Valve

Valve regulation of the structure flow can be defined as part of the culvert definition. Four different valve regulation types are available:

- **None**
No valve regulation applies (flow is not regulated).
- **Only Positive Flow**
Only flow in positive flow direction is allowed. Valve regulation does not allow flow in negative flow direction and the flow through the structure will be zero in this case.
- **Only Negative Flow**
Only flow in negative flow direction is allowed. Valve regulation does not allow flow in positive flow direction and the flow through the structure will be zero in this case.
- **No Flow**
No flow is allowed in the structure. Valve regulation closes completely the structure.

Head loss factors

The Loss Factors determines the energy (Head) loss over the culvert. These are defined in the last eight columns. Each loss factor is defined by a suffix, where '+' indicates Positive Flow direction and; suffix '-' indicates Negative Flow direction.(e.g. 'Inflow -' means inflow loss coefficient for negative flow direction).



Four types of Loss factors are defined for both positive and negative flow directions:

- Inflow (contraction loss)
- Outflow (expansion loss)
- Free flow
- Bends

Lower input data grid

The lower input data grid contains the physical description of the culvert (geometry, invert levels, length, etc.).

A culvert can be defined as one of three Geometry types:

- Rectangular (requires definition of culvert Width and Height)
- Circular (requires definition of culvert (internal) Diameter)
- Irregular (Level-Width relation)
In case of an Irregular shape culvert, the geometry must be defined by a Level-width relationship table.
Pressing the button in the 'Geometry' column opens a Level-Width dialogue where the geometry relation can be entered.

The culvert geometry defines the geometrical shape of the active flow area of the culvert.

In the 'Section Type' column it can be defined whether a culvert structure is a Closed or an Open section type.

In the last five columns, a number of parameters defines specific culvert characteristics:

- 'Upstream Invert' is the Invert level at inflow location of the culvert.
- 'Downstr. Invert' is the Invert level at outflow location of the culvert.
- 'Length' is the length of the culvert.
- 'Manning's n' is the Manning's bed resistance number along the inside of the culvert (for friction loss contribution).
- 'No. of Culverts' is a number identifying how many culverts exist at the specific culvert location with identical geometrical definition.

An example; Five identical shaped draining pipes are placed just next to each other in an earth dam, and in order not to make 5 individual definitions (5 lines) in the culvert page - one for each pipe - the 'No. of Culverts' in this case can be defined as 5 and the simulation engine will



recognise that 5 culverts of identical shape and size are located here and flow calculations will take this into account accordingly..

See also Culverts (p. 105).

3.8.3 Dikes

The dike data are defined in two grid tables in the present page: Upper input data grid and Lower input data grid.

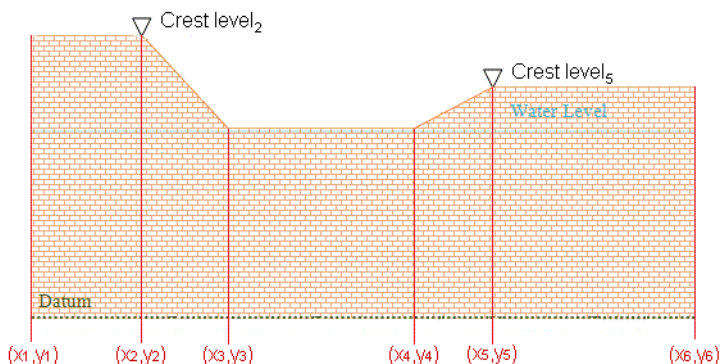

Figure 3.3 Example of dike defined by 6 geo-referenced points

Upper input data grid

The number of dikes must be defined initially. This number defines the number of structure definition lines which will be present for defining the dike input data.

Name

The Name of dike is a user defined ID-string for each dike.



Note: Names must not be identical for different structures included in the model simulations.

Include

It is possible to include or exclude defined dikes from the simulation.

Location

'Location' and 'Projection' columns define the actual location of the dike.

The location in the horizontal domain of a dike is given by a number of geo-referenced points which together make up a polyline. The geographical coordinates are defined in the Lower input data grid shown when pressing the button in the 'Location' column. You must also select the map pro-



jection (Longitude/Latitude, UTM, etc.) in which the specified location coordinates for the dike are defined.

See also Location of a structure (*p. 100*).

Discharge coefficient

For a description of the discharge coefficient see Dikes (*p. 108*).

Delta level

When the water level gradient across a structure is small, the corresponding gradient of the discharge with respect to the water levels is large. This in turn may result in a very rapid flow response to minor changes in the water level upstream and downstream.

As a way of controlling this effect, a critical level difference has been introduced. The critical water level difference defines the water level difference below which the discharge gradients are suppressed. The default setting is 0.01 meter. If a structure shows oscillatory behaviour it is recommended to increase this value slightly.

Crest level information

The crest level of the dike can be specified as

- Constant
- Varying in space
- Varying in space and time

When Constant is specified you have to specify the constant crest level. In case the crest level is varying you have to specify the crest level data in the Lower input data grid for the defined grid points.

Lower input data grid

Location

The location in the horizontal domain of a dike is given by a number of georeferenced points which together make up a polyline. The poly-line defines the width of the dike perpendicular to the flow direction. A minimum of two points is required. The polyline is composed of a sequence of line segments. The line segments are straight lines between two successive points. The polyline (cross section) in the numerical calculations is defined as a section of element faces. The face is included in the section when the line between the two element centres of the faces crosses one of the line segments.

The georeferenced points defining the dike can be specified directly in the dialogue or imported from an ASCII file. The file format is three space separated floats (real numbers) for the x- and y-coordinate and the crest level on separate lines for each of the points.

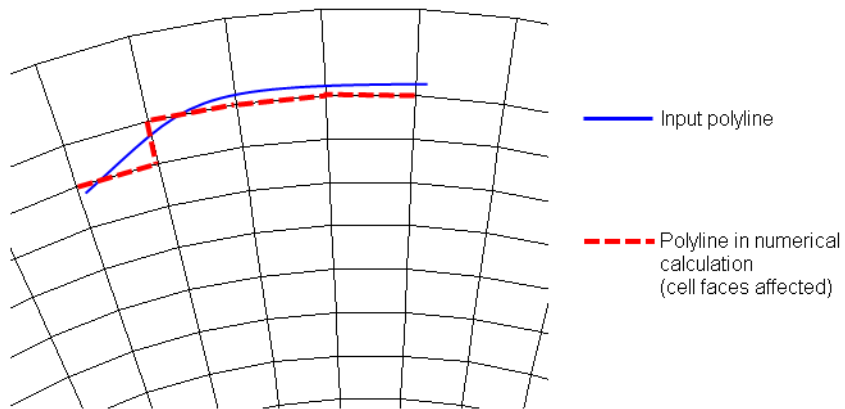

Figure 3.4 The location of a dike. Note the affected cell faces



Note: The faces defining the line section for the dike will be listed in the log file.

Crest level

The crest level of a dike can be specified as:

- Constant
- Varying in space
- Varying in space and time

When the crest level is specified as constant the crest level is defined by the value specified in the Upper input data grid.

When the crest level is specified as varying in space the crest level is defined by the values in the Lower input data grid.

When the crest level is specified as varying in space and time you have to prepare a data file containing the crest level before you set up the simulation. The file must be a dfs1 file, where the number of grid points corresponds to the number of points, which is used to define the location of the dike. The data must cover the complete simulation period. The time step of the input data file does not, however, have to be the same as the time step of the hydrodynamic simulation. A linear interpolation will be applied if the time steps differ.



3.8.4 Composite structures

A composite structure can be composed of a combination of Weirs and/or Culverts.

An example of a composite structure could be a bridge with multiple waterways. Such a structure can be described by a number of culverts, each defining an individual waterway. Additionally, for a potential bridge deck overtopping a weir can be included to describe such overflow.

A set of structures forming a composite structure are recognised by the program from the location definitions. Locations must be completely identical for all the structures forming the composite structure. That is, the table of coordinates defining the structure locations must be exactly identical (number of coordinates and coordinate values) for all structures defined.

3.8.5 Level-width relationship

The geometry of a weir or a culvert may be defined by a level-width relation, where the Level/Width table defines the shape of the active flow area as a set of corresponding levels and flow widths. Values in the levels column must be continuous, increasing values.

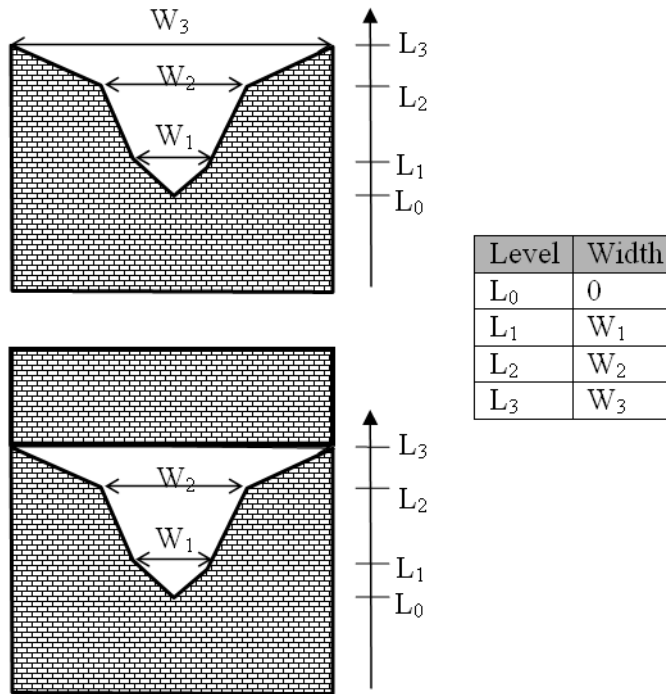

Figure 3.5 Definition sketch of level-width relationship
 Upper: broad crested weir
 Lower: Irregular culvert

3.8.6 Remarks and hints

The implementation of structures in MIKE 21C allows for composite structures consisting of weir and culverts. Thus it is possible to introduce multiple culverts at the same location or say a weir and a culvert at the same location. Each structure is simply defined separately in the interface and the combined flow is handled by the calculation kernel. Examples are given below.

A wide weir with a small opening

Consider a weir as illustrated in Figure 3.6.

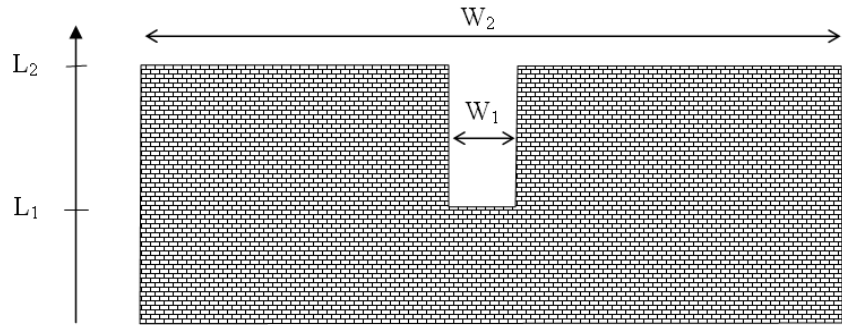

Figure 3.6 Wide weir with a small opening

There are a number of possibilities when modelling this in MIKE 21C:

1. One weir
2. Two weirs with width W_1 and width $(W_2 - W_1)$, respectively
3. Three weirs with widths W_1 and two with width $(W_2 - W_1)/2$, respectively

Using the first approach is only appropriate if the weir can be contained within a single grid cell. The second approach may be used if the weir spans multiple cells, keeping in mind that the flow over the highest crest (L_2) is uniformly distributed over all the affected cells. The third approach will give the best representation of the flow.



Note that the location needs to be defined for each of the segments for case 2 and 3.

A wide weir with multiple culverts

Consider a structure as illustrated in Figure 3.7.

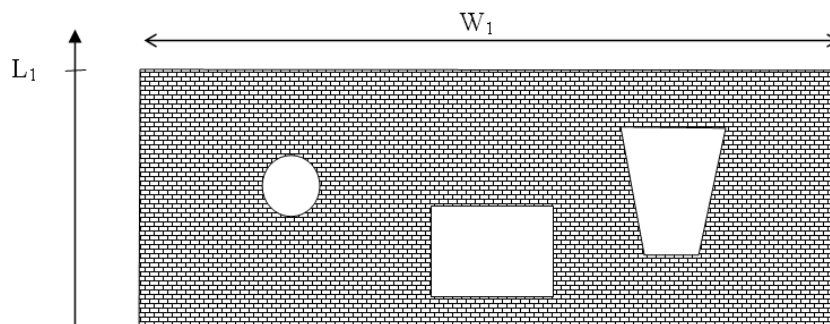

Figure 3.7 Wide weir with multiple culverts

The composite structure should be implemented as four separate structures:

1. A weir with a constant crest level L_1 and a location defined by the full extent of the weir
2. A circular culvert
3. A rectangular culvert
4. A irregular culvert described by a level/width table



Note that the location needs to be defined for each of the four structure components separately. The location line should correspond to the maximum width of the structure component while still obeying the minimum requirement with respect to intersecting a line segments connecting cell centres.

3.9 Results (HD)

Two types of output data can be obtained from a hydrodynamic simulation:

- Results files
- Hotstart files

3.9.1 Results files

A number of data files can be created, with computed fluxes and surface water levels or with water levels only. The amount of model output can be large (or even huge), so sometimes it is impractical to save results in all grid points and at all time-steps. To assist, sub-areas and sub-sets of output can be specified. For each output area you specify, the following information is required:



- J-direction - enter start grid, end grid and grid step in the horizontal direction*
- K-direction - enter start grid, end grid and grid step in the vertical direction*
- Time - enter start time-step, end time-step and time-step increment (limits as specified in Simulation Period) *
- Data File - output file name, which can be type 0, type 1 or type 2 depending on the spatial extent that you have requested +
- Title - optional title for the output area (such as 'Area of Interest')
- Output Items - choice of output of surface water levels or fluxes and water levels
 - * - the box to the right of the Time box provides a dialogue to enter the above information
 - + - the box to the right of the Data File box provides a browser window to enter the file name

3.9.2 Hotstart files

'Hot data', a type 2 data file, can be used to re-start computations. Specify the name of the hot-output file. Optionally, specify a title for the file.





4 River Morphology Parameters

This section provides information on the modelling requirements for river morphology.

Starting Conditions
 Helical Flow
 Sediment Transport
 Planform
 Alluvial Resistance
 Morphological Update
 Boundary (ST)
 Results (ST)

There is a more detailed description in the Reference Manual.



Figure 4.1 Example of river morphology

4.1 Starting Conditions

4.1.1 Simulation period

The time-step range is usually the same as for the hydrodynamic model, but can be modified.



4.1.2 Sub-modules

Five modules can be implemented in the simulation:

1. Helical Flow (pseudo-3D flow around river bends)
2. Sediment Transport (bed load and/or suspended load)
3. Planform (with or without grid updating)
4. Alluvial Resistance (update of friction coefficient)
5. Morphological Update (calculate bed level changes and optionally update in hydrodynamic simulation)

4.1.3 Morphological time-step

The modules listed above are activated at a time-step relative to the hydrodynamic time-step. This morphological time-step is the hydrodynamic (or general) time-step multiplied by the (integer) time-step frequency.

4.1.4 Morphological drying depth

The morphological drying depth is used as a criterion on the water depth in each computational cell, such that no morphological activity takes place in cells where the water depth is smaller than the morphological drying depth. This is ensured by setting all sediment transport in and out of a cell with insufficient water depth to zero, both directly in the sediment fluxes, and also in the fluxes that appear in the advection-dispersion equation. Hence no sediment can enter or leave such a cell.

The valid range for the morphological drying depth is:

- Must be larger than or equal to the hydrodynamic drying depth
- Must be smaller than or equal to the hydrodynamic flooding depth

The hydrodynamic drying and flooding depths are found in the Flood and Dry dialogue for cold started simulations. For hot-started simulations these two depths are read from the hot-start file, and therefore there is no Flood and Dry dialogue for hot-started simulations. If using a hot-started model, the hydrodynamic drying and flooding depths can be found in the input file (.M21C) for the hydrodynamic simulation that was used for generating the hot-start file, or alternatively (only for expert users) the depths can be read from the actual hot-start (dfs2) file.

Stability problems can occur when attempting to model sediment transport in very shallow cells. The primary reason for this is that the hydrodynamic model can result in unrealistic shear stresses for very shallow water, especially when the water depth is close to the drying depth.



The morphological drying depth can be used for curtailing stability problems. However, the maximum concentration allowed to erosion is a much more powerful tool because it has the ability to essentially ignore unrealistic shear stresses by not allowing such to result in unrealistic erosion rates.

4.1.5 Implicit AD solver

The implicit AD solver is used for solving the advection-dispersion equations associated with the helical flow and all sediment fractions with suspended sediment transport activated. In the implicit AD solver the advection-dispersion equation is solved using the morphological time-step. The resulting sparse matrix equation is solved with a parallelised iteration method involving the parameters:

- **Maximum number of iterations:**
The maximum number of iterations allowed in the iterative sparse matrix solver. This should not be set too low, as it may cause the iterations to not capture the dynamic solutions properly. Recommended range is usually 10-30 iterations.
- **Relaxation factor:**
This can be used for relaxing the solutions, and should be in the range 0-2. However, usually there is little to gain from setting the parameter higher than 1 (and there is a risk of a diverging solution), and some safety can be added by setting the factor smaller than 1.
- **Stop criterion:**
The stop criterion applies to the residual in the equation normalised with the magnitude of the solution. A value in the range 10^{-12} - 10^{-6} will usually work, and high values should not be used, as this may result in equations that are not properly converged.



The AD equations are strongly source/sink dominated, and the helical flow has no dispersion. Therefore the helical flow AD equation is usually very easy to converge. For suspended sediment the equations are still source/sink dominated, but the equations also contain significant dispersion terms from the profile functions, which can cause slower convergence for fine sediment.

4.1.6 Log output

The Log output allows the user to set a frequency for morphological log output to the MIKE 21C log file. The reasons are that

- Log output is useful for determining whether a morphological model is running properly. Does it have reasonable AD equation convergence? Do the bed levels change too fast?



- Having log output at every morphological time-step can produce gigantic log files, so output only at a frequency (e.g. daily).

The time-period is calculated as the log frequency times the morphological time-step.

The log output could look like this:

Time-step #:		14400				
	frac	residual	it	minimum	maximum	
AD	0	0.12E-06	1	-1.0	0.55	
AD	1	0.78E-02	5	0.0	0.10E+06	
AD	2	0.39E-02	3	0.0	0.21E+05	
AD	3	0.20E-02	3	0.0	0.10E+05	
AD	4	0.49E-03	3	0.0	0.36E+04	
	frac	minimum	(j,k)	maximum	(j,k)	
DZ	1	-0.0001762	(224, 34)	0.0004785	(25, 26)	
DZ	2	-0.0037533	(12, 34)	0.0060195	(191, 31)	
DZ	3	-0.0047306	(2, 34)	0.0053975	(11, 35)	
DZ	4	-0.0046394	(2, 34)	0.0038372	(11, 35)	
DZ	5	-0.0011498	(4, 34)	0.0012706	(11, 35)	
DZ	6	-0.0003385	(2, 34)	0.0004981	(11, 35)	
DZ	7	-0.0001740	(5, 34)	0.0001328	(11, 35)	
DZ	8	-0.0001899	(5, 34)	0.0000970	(6, 35)	
DZ	9	-0.0000441	(5, 34)	0.0000507	(6, 35)	

Figure 4.2 Example of log output

The first part (AD) involved AD equations:

- The fractions are listed as “frac”, i.e. from 0-4 in this case
- Fraction 0 is the helical flow
- So in this case there are 4 sediment fractions with suspended sediment
- The “residual” column contains the residual (error) in the solution
- The “it” column is the number of iterations used by the solver
- “minimum” and “maximum” is the range (note that the helical flow can become negative, which is not the case for the suspended sediment concentrations). For suspended sediment the values are concentrations in [g/m³].

The second part (DZ) involves the bed level changes during the morphological time-step:

- Now “frac” will be all the sediment fractions, i.e. 9 in this case.
- The “minimum” bed level change (maximum scour [m]) along the cell (j,k) in which it took place



- The “maximum” bed level change (maximum deposition [m]) along the cell (j,k) in which it took place

The bed level changes are very useful for figuring out whether the morphological time-step is reasonable. If a too high morphological time-step is selected, it will in most cases result in bed level changes that become quite high (although they are still limited by e.g. local sediment availability), and often increasing in time. As a rule of thumb bed level changes during a time-step for each fraction should be in millimeters to centimeters, although it is difficult to make general rules due to scale variations.

4.2 Helical Flow

Helical flow is included via the calibration parameter α . This is entered either as a constant value throughout the model domain, or as a spatially varying value from a type 2 (grid) file.

A limiting angle between the depth averaged flow shear stress direction and the helical flow shear stress direction can also be specified ($\tan \delta_s$).

See also the Reference Manual, Helical Flow (p. 79) for more information.

4.3 Sediment Transport

This dialogue contains information concerning the simulation of sediment transport in MIKE 21C.

For the specified Number of Fractions, the following information is required.

Note that for uniform sediment simulations based on d_{50} grain sizes, only use one fraction:

- Fraction Name
If ‘Fraction 1’ is not meaningful enough.
- Type
Non-cohesive (sand) or cohesive sediment types are supported. Note that only one fraction can be specified as cohesive. Specifications for the cohesive fraction can only be specified by use of optional parameters.
- Porosity
Porosity of the bottom sediment is usually in the range of 0.3 to 0.7.
- Density
Density is specified as the relative density of the sediment compared to water density ($\rho_{solid} / \rho_{water}$). Thus, for sand, a typical value is 2.65.



- Critical Shields Parameter
The initiation of particle movement depends on the Critical Shields Parameter, θ_{CR} . See the Reference Manual for more information.
- Use Egiazaroff hiding function
When more than one sediment fraction is simulated, the Egiazaroff hiding function can be selected.



Note that if more than one fraction is specified, a graded sediment model is used (at least one sediment layer is then required). For more information on graded sediments, see the reference manual.

There are more dialogues relating to sediment transport modelling:

Bed slope effect
Fall velocity modification
Grain size
Dispersion coefficient
Transport theory

4.3.1 Bed slope effect

The bottom-left box contains information on the sediment transport due to transverse Bed slope effects:

- Transverse slope coefficient (G)
Depending upon the value of a (see below), the transverse slope coefficient typically varies between 0 and 3.
- Transverse slope power (a)
The value of transverse slope power is typically between 0.5 and 1.0
- Longitudinal slope coefficient (e)
The value of the longitudinal slope coefficient is typically between 1 and 10.



Note that this value has less influence on sediment transport compared to G and a .

See the Reference Manual Bed Slope (p. 63) for more information.

4.3.2 Fall velocity modification

The bottom-right box contains information on suspended sediment:

- Factor on fall velocity (a)
This factor can be used to modify the space and time lag in suspended sediment.



For more information see the Reference Manual, Suspended Load (p. 110).

4.3.3 Maximum concentration allowed due to erosion

This parameter limits the erosion that can take place during a morphological time-step in such a way that the erosion cannot take place if it causes the sediment concentration to go above the specified maximum value. The limit applies to both bed load and suspended load.

For bed load it is applied in the form of translating the maximum concentration into a change in the sediment mass in the bed during the morphological time-step.

For suspended load the limit is used directly on the erosion function appearing on the right hand side of the advection-dispersion equation.

The Maximum concentration allowed due to erosion parameter is critical for morphological stability, but should be used with caution, as very low limits will suppress physics.

4.3.4 Grain size

Grain size can be specified either as a constant value throughout the model domain, or as a spatially varying value from a type 2 (grid) file. The d_{50} median grain size is generally used for a single sediment fraction where grain size analysis is available.

If using a graded sediment model, grain sizes for each fraction are specified. Note that for graded sediment, each fraction must have a constant grain size (not a spatially varying value from a grid file).

4.3.5 Initial concentrations

Initial concentrations can be specified for cohesive sediment fractions. This can be specified either as a constant value throughout the model domain or as a spatially varying value from a type 2 (grid) file.

For non-cohesive sediment fractions, MIKE 21C always uses the equilibrium concentration (varying in the domain) calculated internally from the selected sediment transport formula. Using the equilibrium concentration as initial condition means that initially the rate of bed level change will always be zero because the erosion and deposition functions are identical.

Initial concentration applies only to sediment fractions with suspended load activated. The calculation of bed load in MIKE 21C is done explicitly at each time-step, and therefore no initial condition is required for bed load.



4.3.6 Dispersion coefficient

For suspended sediment transport, the dispersion coefficients represent mixing due to

- Non-uniform vertical flow and concentration profiles
- Secondary (helical) flow

Dispersion coefficients can be specified in two ways (see the top box):

- Independent of the current

The dispersion coefficient can be specified as a constant value throughout the model domain, or as a spatially varying value from a type 2 (grid) file. The dispersion coefficients can be different in the x (or main flow) direction compared to the y (or transverse direction).

- Proportional to the current

The dispersion coefficients can be specified as a proportion of the hydrodynamic flow density, and are re-calculated at each time-step. Again, the dispersion coefficients can be different in the x (or main flow) direction compared to the y (or transverse direction).

Giving advice on what dispersion coefficients to use is difficult, as values can vary significantly from one application to another. Note that dispersion coefficients in a mathematical model are not only dependent upon the physics of the problem, but also are grid size and time-step dependent.

The dispersion specified in the GUI is additional dispersion, and most MIKE 21C models do not require adding any dispersion via the dispersion dialogue. The reason is that MIKE 21C already adds dispersion to the suspended sediment concentration advection-dispersion equations originating from the profile functions. These dispersion coefficients can be significant, especially in the flow direction due to the logarithmic velocity profile. If not adding any dispersion via this dialogue MIKE 21C will only use the dispersion from the profile functions in the suspended sediment advection-dispersion equations, while the helical flow adaptation equation will be a pure advection equation (no dispersion).

For further information, see the Reference Manual Dispersion Coefficients (p. 74).

4.3.7 Transport theory

Seven sediment theories are presently available in the model:

- Engelund and Hansen
- Van Rijn



- Engelund and Fredsoe
- Meyer-Peter and Muller
- Empirical formula (Smart and Jaeggi)
- Yang for sand
- Yang for gravel

The top box contains information on the bed load formula and the bottom box information on the suspended load formula. Use an 'X' in the respective box to activate one or the other or both.

- **Bed load**
For bed load, a bed load factor can be applied to the selected transport formula. The default value is 1, and values can vary between 0.5 and 2.0. Beyond this range the validity of the chosen formula could be questioned.
- **Suspended load**
For suspended load a suspended load factor can be applied to the selected transport formula. As for bed load the default value is 1, and values can vary between 0.5 and 2.0. Again, beyond this range the validity of the chosen formula could be questioned.

Some of the sediment theories are based on a total load concept. For these cases the sediment load should be divided into bed load and suspended load, so that the sum of the factors are equal to 1.

For further information, see the Reference Manual Sediment Formulae (p. 98).

4.4 Planform

4.4.1 Bank erosion

The top-left box contains information for Bank erosion:

- **Number of eroding banks**
The details of each eroding bank is specified in Specifications for bank lines.
- **Maximum bank erosion**
At each time-step bank erosion is limited to this value.
- **Include erosion in sediment budget**
If the banks have a similar sediment composition to the river bed itself, then bank erosion should be included in the sediment budget.



- Update grid during simulation
This option allows updating of the curvilinear grid during computation. This is described in the Grid Generation Users Guide.

4.4.2 Curvilinear grid

If Update grid during simulation has been specified, the right box contains information on the Update of grid:

- Output grid file
This type 2 (grid) file contains the updated x and y coordinates of the generated grid.
- Land points
Each box represents the number of land points defined along each boundary in a clockwise direction; North, East, South and West. For example, if a model has an upstream west flow boundary, a downstream east water level boundary, a row of grid points defining the north land boundary and two rows defining the south land boundary, the entries would be 1 0 2 0.
- Courant criterion for update
When the accumulated bank erosion at any point on the eroding banks is more than this value multiplied by the local transverse grid spacing, grid generation is initiated. If initiated, the accumulated bank erosion is reset.
- Move bathymetry opposite of grid
This may seem as a strange thing - use your pencil to understand why!
- Freeze internal true land
During grid generation true land points can be specified inside the model area. This option will fix the locations of these points. Note that this option may violate the orthogonality criterion if the grid changes significantly.
- Solution control
This box controls the iterative procedure of the grid generation. Iteration continues until the specified convergence criterion for orthogonality is fulfilled or the maximum number of iterations is exceeded.
- Smoothness control
The simulated bank lines are smoothed before being applied as the new boundary line coordinates:
 - A number of Sweeps on bank line changes are performed to smooth along the new coordinates.
 - A number of Sweeps on grid weight are performed using the previous grid.
 - A Maximum bank line curvature provides an upper limit on bank line shape.



- A Maximum grid weight curvature provides an upper limit on bank line shape.

For more information, see the Reference Manual Update Computational Grid (p. 114).

4.4.3 Specification for bank lines

If Bank erosion is specified (see *Number of Eroding Banks*), the bank lines need to be specified. For each bank line, enter the First point and the Last point. The factors for each bank line are as follows:

- The Alpha (α) factor controls the influence of transverse bed slope on bank erosion. Typical values are between 0 and 20.
- The Beta (β) factor controls the influence of sediment transport on bank erosion. Typical values are between 0 and 0.1.
- The Gamma (Υ) factor is a time-constant factor independent of transport or bed slope.
- The Height (hb) is the elevation of the bank.

For further information, see the Reference Manual Bank line update (p. 61).

4.5 Alluvial Resistance

Alluvial Resistance can be included by updating the Chezy coefficient (C) according to the equation:

$$C = aH^b$$

where:

H is local water depth

a is the Resistance coefficient

b is the Resistance Power

The calculated Chezy coefficient is limited by a Minimum resistance and a Maximum resistance.

The Resistance coefficient and the Resistance power can be specified as a constant or as a spatially varying value using a type 2 (grid) file.

Note that an initial resistance map needs to be defined for the HD, when alluvial resistance is applied.

See the Reference Manual Alluvial Resistance (p. 59) for more information.



4.6 Morphological Update

- Number of layers = 0
The river bed is considered to be comprised of a single layer of infinite depth.
- Number of layers = 1 (or more)
The river bed is comprised of one or more layers of given thickness and composition. A Layer Name can be specified for each layer (if 'Layer 1', 'Layer 2', etc is not informative enough).

If using a single sediment fraction there cannot be more than one layer (Number of layers = 0 or 1). To simulate more than one layer a graded sediment model is required. Further information on the Layer Thickness and the Component Percentage are in separate dialogues.

If using more than one sediment layer, there must be at least two sediment fractions.

Up to 16 sediment layers can be prescribed.

4.6.1 Equilibrium layer thickness

The bottom left box contains information on the Equilibrium Layer Thickness, which is activated if the Number of Layers is greater than zero. This defines the thickness at which full sediment transport capacity is utilised:

- Factor on depth
A factor applied to the local water depth to determine the equilibrium layer thickness.
- Minimum value
The lower limit on the equilibrium layer thickness.
- Maximum value
The upper limit on the equilibrium layer thickness.

The equilibrium layer thickness is used differently in 1-layer and N-layer models ($N > 1$).

The equilibrium layer thickness is the layer thickness for which the sediment transport is not scaled down due to lack of local sediment availability.

When there are two or more layers the equilibrium layer thickness is used as the target thickness for the active layer, which is ensured by moving the interface between the active (layer-1) and passive (layer-2) layers. If there is no sediment available in the passive layer, the active layer can become thinner than the equilibrium layer thickness.



4.6.2 Morphological update

The morphological update contains:

- **Update bathymetry:**
When this is checked the bathymetry will be updated during a simulation, while if not checked, sediment transport and bed level changes are still calculated, but not added to the bathymetry, i.e. no feedback to the hydrodynamics. Usually one will want to update the bathymetry.

When the bathymetry is updated, the water level is updated as well to keep the water depth unchanged.

- **Average inflow sedimentation:**
When checked inflow boundaries will be subjected to averaging of the sedimentation rate during each time-step. This can be utilised to keep inflow boundaries at the same level in all cells across the boundary. The process applies to the cells spanning the inflow boundary and two cells into the model bathymetry, as shown below. The process is particularly useful for boundaries with prescribed sediment inflow, while boundaries with “bed level change” type boundary condition are not subjected to the process.

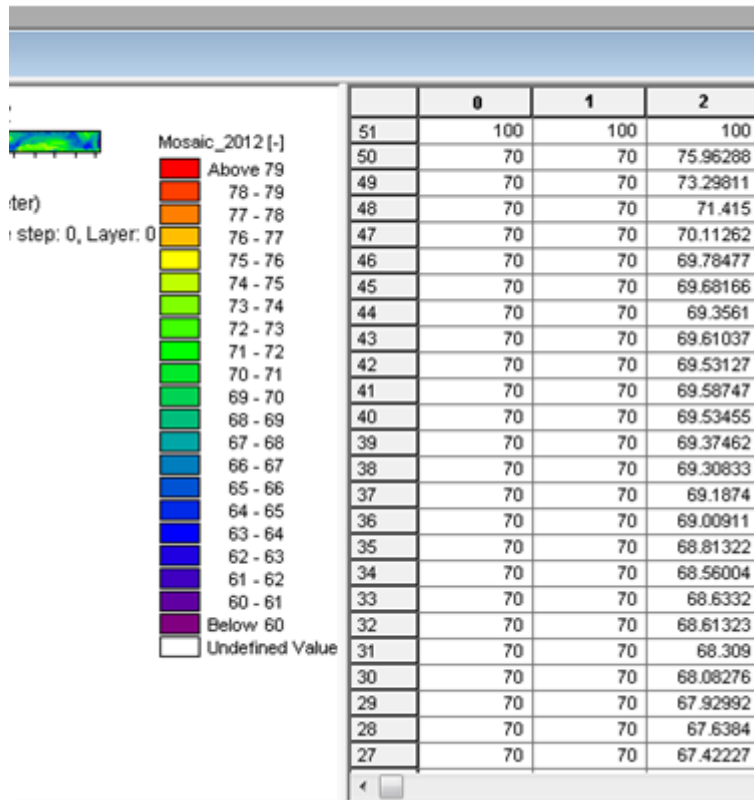

Figure 4.3 How to use averaging of the sedimentation rate over a boundary. If starting the simulation with the same bed level across the boundary, the averaging process will cause all the elevations (initially 70 m) to move up and down evenly. This is often necessary to avoid flooding and drying on a boundary during a morphological calculation

- Average all boundary sedimentation

When checked the process described above applies to all boundaries, except boundaries that have the “bed level change” type.

The averaging of sedimentation over boundaries is often necessary due to the inherent shortcomings in morphological boundaries.

At inflow boundaries the redistribution of bed levels when using sediment inflow conditions can sometimes lead to drying of cells in the boundary, and the sedimentation averaging method is very effective at curtailing such developments.

At outflow boundaries the boundary condition is always ignored due to the hyperbolic nature of the sediment continuity equation; the morphological solution is calculated using the locally calculated sediment transport vector from the flow solution at such boundaries. Outflow boundaries can also result in local cells drying out. A development sometimes seen is that an outflow



boundary develops scour in some cells, which then attract more flow and so forth. This is an inherent problem caused by the missing connection between sediment outflow and water level at an outflow boundary. In reality significant sediment outflow over a portion of an outflow boundary will cause sedimentation downstream, and therefore deflect the flow away from the local portion, but this is not accounted for when using a morphological boundary.

If using bed level change at an outflow boundary the sedimentation will not be subjected to averaging. Therefore, when in need of sedimentation averaging over an outflow boundary one obviously needs to use either a sediment transport or concentration boundary condition (the value is ignored). Sediment transport (total over the boundary) and concentration conditions are handled differently, with the sediment transport condition being more sensitive to boundaries with varying inflow and outflow (typically for tidal boundaries where the flow direction changes at varying points in time over the tidal boundary), while the sediment concentration condition just results in direct application of the concentration if any cells in the boundary have water inflow. As a result it is often better to use zero sediment concentration on outflow boundaries when needing to average the sedimentation rate.

As a rule of thumb the area of interest should be kept well away from boundaries when modelling morphology in MIKE 21C.

4.7 Layer Thickness

The thickness of each layer can be specified as a constant value or as a spatially varying value from a type 2 (grid) file.

4.8 Component Percentage

The composition of each river bed layer is specified as a percentage of each sediment fraction. The percentage of each fraction in a layer can be specified as a constant value or as a spatially varying value from a type 2 (grid) file. Note that this information is important only for a graded sediment model - if using a single fraction then 100% of the river bed layer will consist of this fraction.

4.9 Boundary (ST)

Each boundary in the model requires a River Morphology (RV) boundary. There are a number of boundary types available. Each boundary condition can be constant, a time series (time dependent, where a type 0 file is specified), or a line series (time and space dependent, where a type 1 file is specified):

- Bed level change, Constant
A constant bed level change rate must be specified.



- Bed level change, Type 0 file
A time dependent bed level change rate must be specified.
- Bed level change, Type 1 file
A time and space dependent bed level change rate must be specified.
- Transport, Constant
A constant total transport is specified for each sediment fraction.
- Transport, Type 0 file
A time dependent total transport is specified for each sediment fraction.
- Transport, Type 1 file
A time and space dependent total transport is specified for each sediment fraction.
- Concentration, Constant
A constant concentration is specified for each sediment fraction.
- Concentration, Type 0 file
A time dependent concentration is specified for each sediment fraction.
- Concentration, Type 1 file
A time and space dependent concentration is specified for each sediment fraction.

4.10 Results (ST)

A Number of Output Areas can be created. The amount of model output can be large (or even huge), so it is often not possible to save results in all grid points and at all time-steps. To assist, sub-areas and sub-sets of output can be specified.

4.10.1 Output areas

For each output area you specify, the following information is required:

- J-direction - enter start grid, end grid and grid step in the horizontal direction*
- K-direction - enter start grid, end grid and grid step in the vertical direction*
- Time - enter start time-step, end time-step and time-step increment (limits as specified in Simulation Period)*
- Data File - output file name, which can be type 0, type 1 or type 2 depending on the spatial extent that you have requested+



- Title - optional title for the output area (such as 'Area of Interest')

* - the box to the right of the Time box provides a dialogue to enter the above information

+ - the box to the right of the Data File box provides a browser window to enter the file name

4.10.2 Save properties

The Save properties box provides options on what to save:

- Helical flow intensity - Results of the computed deviation of bed shear stress direction compared to depth averaged flow direction.
- Single Fraction Number - If selected, only the specified sediment fraction will be saved. If not, the sum of all fractions is saved.
- Single Layer Number - If selected, only the specified layer will be saved. If not, the sum of all layers is saved.
- Bed Load - Computed bed load transport (excluding porosity).
- Suspended Load - Computed suspended transport (excluding porosity).
- Concentration of sediment - Computed concentrations of suspended sediment.
- Total Load - Bed load plus suspended load (transport), excluding porosity.
- Water Surface Elevation - The water surface elevation, including bed level changes due to morphological change. The water surface elevations saved in the HD Result file are relative to the original bathymetry. The results stored here are updated at each time-step to account for bed level change.
- Bed level - Computed bed level.
- Bed level change - Change in bed level, with deposition positive and erosion negative.
- Bed resistance - Computed bed resistance factor (g/C^2). Dimensionless.
- Bank erosion - Computed bank erosion.
- Mean grain size - If using a graded sediment model, the mean grain size is saved.
- Shear stress - bed shear stress in each cell.



- Layer thickness - Computed thickness of each bed layer, and the total thickness.

The Save for all fractions and layers dialogue contains:

- Layer thickness – if checked the model will store the thickness of all layers and all fractions shown in the result file as “Thickness (ilayer,ifrac)”
- Concentration – the concentrations for all sediment with suspended load activated is written to the result file, in addition to the total sediment concentration.
- Sediment transport – the bed load (if activated) and suspended load (if activated) vectors will be written for all fractions

Fractional output:

- Fractional layer thickness – the integrated layer thickness for each fraction is written, i.e. the sum of all layer thicknesses over the layers for each fraction. This is useful in cases where a large number of layers are simulated, and the user does not need to know the vertical distribution of the substrate.



5 Reference Manual

The Reference Manual provides a more detailed description of the components of MIKE 21C.

The hydrodynamic module of MIKE 21C is similar to the standard MIKE 21 hydrodynamic module. Please see [M21HD.pdf](#) for further information.

Specific to MIKE 21C is this River Morphology Reference Manual, which also contains supplemental information on hydrodynamics.

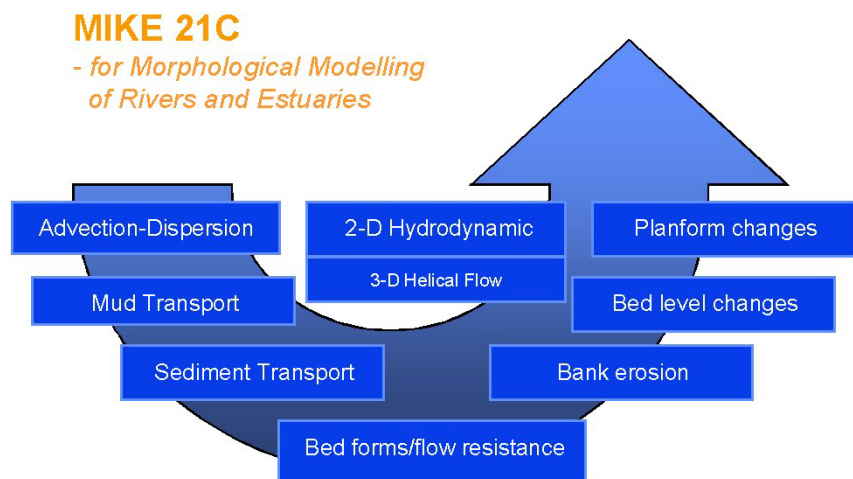

Figure 5.1 Illustration of MIKE 21C parameters

5.1 Adaption Lengths

5.1.1 General

The two-dimensional mathematical modelling of river morphology is based on a number of differential equations representing the prevailing physical processes:

- Flow momentum equations
- Flow continuity equation
- Advection-dispersion model of suspended sediment
- Advection-dispersion model of secondary flow inertia
- Stream-line curvature
- Suspended Load model
- Bed load model



- Direction of bed load and bed slope influence
- Sediment continuity equation

By carrying out linear stability analyses of the system of equations governing the morphological simulation, it is possible to derive adaptation lengths of different physical processes:

- adaptation of the main flow
- adaptation of the bed deformation
- adaptation of the depth-averaged concentration

Olesen (1987) and Talmon (1992) describe this analysis in depth. The ratios between these length scales determine the physical behaviour of the river and the requirements of the mathematical model to reproduce this. It is recommended that these ratios are computed prior to model simulation to get an idea about the physical behaviour, and to get information about likely model results.

5.1.2 Main flow adaptation

A measure of the relative importance of friction forces compared to flow inertia forces is the number:

$$\lambda_w = \frac{C^2}{2g}h \quad (5.1)$$

where

C is the Chezy number

h is the flow depth

g is gravity

If k is the wave number of bed disturbances (such as bars), the number $k\lambda_w$ can be interpreted as the ratio of flow momentum to bed friction.

For large values of $k\lambda_w$, flow momentum dominates and flow will only be deflected slightly above a bar. This means that the bar is not likely to develop very much in height, neither in reality nor in the mathematical model. As mentioned in *Space step selection*, it is important to choose an appropriate grid spacing to describe the bed deformation wave.

For small values of $k\lambda_w$, flow will be deflected and bar growth is enhanced. The effect of gravity on the grains (see *Bed Slope*) will counteract and contribute to a state of equilibrium of the river bed.



5.1.3 Bed deformation adaptation

Sediment transport is induced by flow and adjusted by bed slope. The following length scale characterises the importance of the bed slope:

$$\lambda_s = \frac{1}{\pi^2} \left(\frac{W}{h} \right)^2 \frac{h}{G} \quad (5.2)$$

where

h is the water depth

G is the transverse bed slope coefficient

W is the channel width

The transverse bed slope coefficient describes the influence of transverse bed slope on the direction of the bed load transport:

$$\tan \psi = \tan \delta + G \cdot \frac{\partial z}{\partial n} \quad (5.3)$$

where

z is the bed level

n is the transverse coordinate

d is the direction of the bed shear stress

The number $k\lambda_s$ can be interpreted as the ratio of flow induced divergence of sediment flux to bed slope induced divergence of sediment flux.

For small values of λ_s , bed-slope induced bed load transport is important and the bed topography will tend to self-stabilise. For larger values, flow-induced sediment fluxes dominate and larger transverse bed slopes are required to maintain steady conditions and to balance the two driving forces. The value of G is important in this respect, and must be determined from calibration (see also *Scientific Background*). If G is too small an instability of the numerical solution may be generated, because transverse slopes become too steep before an equilibrium bed is reached.

5.1.4 Concentration adaptation

The suspended sediment concentration does not adapt immediately to local conditions but lags behind due to settling, diffusion etc. The suspended sediment transport part of the flow-induced sediment fluxes is therefore not in equilibrium but lags behind. A measure of the concentration lag is the adaptation length:

$$\lambda_c = a \cdot \frac{\bar{u} \cdot h}{w_s} \quad (5.4)$$

where

u is the depth-averaged velocity

w_s is the grain fall velocity

a is a non-uniformity factor that depends upon the actual concentration profile (range between 0 and 1).

$k\lambda_c$ can be interpreted as the ratio of retarded sediment entrainment to local adaptation. For small values of $k\lambda_c$, adaptation occurs almost immediately and the divergence of flow-induced sediment transport is hardly affected by suspended sediment. For large values, the time and space lag in concentration adaptation increases. The divergence of flow-induced sediment flux is therefore decreased due to the presence of suspended sediment, which tends to stabilise the bed topography.

5.1.5 Oscillations in bed deformations

Solution of the linearised equations in terms of wave numbers and wave damping of bed topography oscillations are presented by Olesen (1987) and Talmon (1992). An example is shown in Figure 5.2.

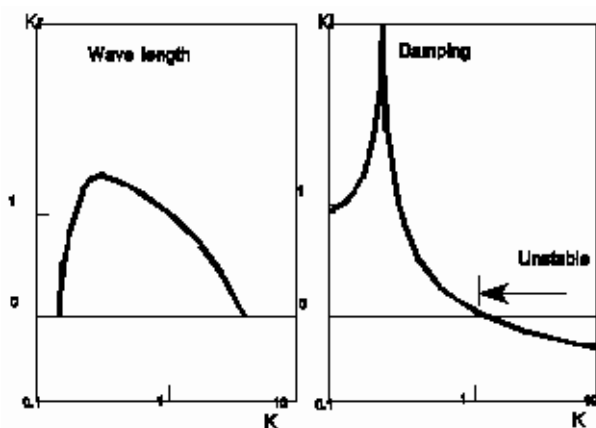

Figure 5.2 Wave number (K_r) and wave damping (K_i) as function of the interaction parameter K

As shown, the interaction parameter $K = \lambda_s / \lambda_w$ is important. For small values of K , the wave number is relatively high (short waves) and damping is high. This situation corresponds to a straight or a meandering river. For large values of K the wave number is less (larger waves) and damping decreases. This situation corresponds to a braided river, with development of islands and new channels.

Note that damping can become negative, at which point an instability occurs. This instability is exaggerated in the linear analysis because of the approximations. In reality, non-linear effects will modify the bed deformations.



5.1.6 Hints

By estimating K before a simulation, it is possible to foresee the kind of results the model will produce. Moreover, if the model gives instability problems, it may be due to either 'natural' instability or unrealistic parameters (for instance G) governing the morphological development.

5.2 Alluvial Resistance

There is an option to use an alluvial roughness coefficient, which is a function of the local depth at every time-step. The Chezy number or the Manning number can be updated as follows:

$$C = A \cdot h^b \quad (5.5)$$

Inclusion of the resistance updating effects simulated scour and deposition patterns. Flow is deflected more over shallow parts, and sediment transport increases due to increased bed shear stresses. In general, this reduces overshoot effects when bed scour commences, and causes the topography of a point bar crest to become more rounded (as reported by *Talmon, 1992*).

A 2D map of bed resistance (for the HD) must be specified initially in the simulation if alluvial resistance is implemented. The user specifies minimum and maximum values of bed resistance. To avoid model instability, the maximum Chezy number should normally be less than $90 \text{ m}^{0.5}/\text{s}$.

If hydrodynamic calibration of the bed resistance shows a certain relationship between local depth and (say) Chezy number, when running the morphological model an alluvial roughness coefficient should be specified using the same parameters.

5.3 Bank Erosion

Bank erosion can be included in the continuity equation for the sediment transport model:

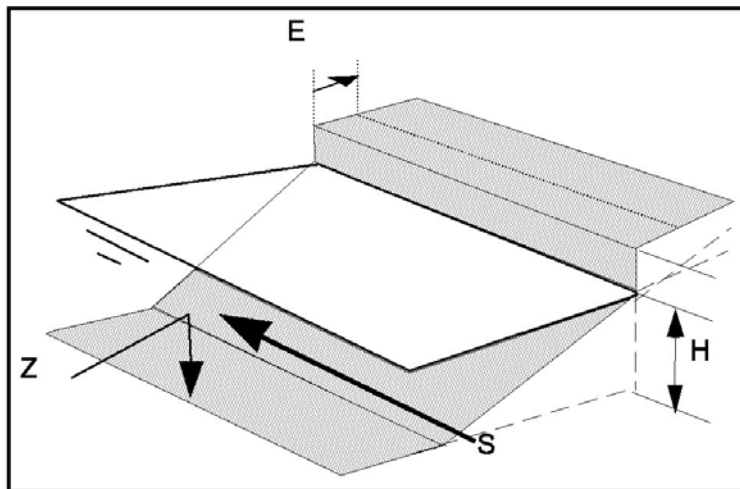

$$E_b = \alpha \cdot \frac{\partial z}{\partial t} + \beta \cdot \frac{S}{h} + \gamma \quad (5.6)$$

where:

E_b is the erosion rate

z is local bed level

S is the near bank sediment transport

h is local water level

α , β and γ are parameters specified in the model input

The additional sediment from this source is

$$\Delta S = E_b(h + h_b) \quad (5.7)$$

where h_b is the height of the bank above the water level.

The near bank slope dependency is included in the first term. The dependency upon the near bank shear stress exerted from the river flow is implicitly included in the second term. The third term (γ) represents a constant erosion rate independent of hydraulic conditions.

The first term is based on the assumption that the shape of the transverse bed profile does not change. Therefore, from geometrical considerations the bank erosion rate must be proportional to the bed erosion. The coefficient α corresponds to the transverse bed slope. Typical transverse bed slopes are in the order of 5-20 along eroding banks. Therefore, the range of α is between 0 and 20.

The second term is derived by assuming that the eroded material $E_b h$ has to be removed by sediment transport S , or at least a fraction (β) of it. This



assumes that the bank consists of the same sediment material as the riverbed. If this is the case, β should not be more than 0.1.

Observed bank erosion rates must be used to calibrate values for α and β . If no evidence of a relationship to dz/dt or S is found, the option is available to give a time-constant bank erosion rate γ .

5.3.1 Graded sediment

If more than one fraction of sediment is simulated, the model assumes implicitly that all eroded material has the same grain size distribution as the bed material at that location. This means that bank erosion will not directly affect the grain size distribution in the riverbed.

5.3.2 River bed update

As mentioned above, bank-eroded sediment contributes to the continuity equation. This usually means that simulated river bed scour is less when bank erosion is included.

5.3.3 Bank line update

An option is available so that if the accumulated erosion along a bank line exceeds a predefined threshold, the curvilinear grid is updated according to changes in the bank line. For more information, see Planform Movements.

5.4 Bed Load

The model has three options for sediment transport calculations:

1. bed load only (or total load)
2. suspended load **and** bed load
3. suspended load only

Bed load is computed explicitly using a selection of seven different bed load models:

1. Engelund and Hansen
2. Van Rijn
3. Engelund and Fredsoe
4. Meyer-Peter and Muller
5. Empirical formulation (Smart and Jaeggi)
6. Yang for sand

7. Yang for gravel

For more information, see Sediment Formulas.

On a horizontal bed, transport direction will coincide with the direction of bed shear stress (which may deviate from the depth-averaged flow direction due to helical flow). On a sloping bed, gravity will influence transport direction, which is essential for bend scour development and formation of bed oscillations (discussed in Bed slope).

For applications with fine sandy material, where most sediment transport occurs as suspended load, it is possible to assess the effect of bed load transport by switching off this component.

To use a total load model without log effects, specify a bed load model and switch off the suspended load model.



Note that a simulation with a total load model and a simulation with a combined bed load and suspended load will not necessarily give the same results. The reason for this is that equilibrium sediment transport (calculated by total load model) will never be reached in non-uniform flow conditions, due to the inherent time-phase lag in the advection-dispersion description of suspended load. The higher the fall velocity (or the coarser the sediment), the less the time-phase lag.

5.5 Bed Resistance

Flow resistance is modelled in two ways:

1. by including Reynolds stresses describing horizontal exchange of momentum through local eddies (referred to as eddy viscosity); and
2. by including the bed resistance describing vertical exchange of momentum.

A description of bed resistance is given in the Hydrodynamic Users Manual.

Bed resistance defined with a Chezy or Manning number in the hydrodynamic model must account for skin friction over the riverbed as well as form friction due to dunes and other larger bed forms.

Model bathymetry is closely linked to model bed resistance. If bathymetric resolution is coarse, bed resistance should be higher to account for smaller bed forms not resolved by the bathymetry description.

Flow resistance is an important factor in the sediment transport formulae. It can be included in two ways:



1. as a measure of the actual bed roughness, where only the so-called skin friction is included; and/or
2. as a measure of the general water surface slope, where total bed resistance is included.

Consider the Engelund-Hansen formula (1967??):

If $\theta > \theta_c$ then

$$S_H = 0.05 \frac{C^2}{g} \theta^{\frac{5}{2}} \sqrt{(s-1)gd_{50}^3} \quad (5.8)$$

The Shields parameter is

$$\theta = \frac{\tau}{\rho g(s-1)d_{50}} = \frac{u^2}{C^2(s-1)d_{50}} \quad (5.9)$$

Bed resistance is represented in the Engelund-Hansen formula by the Chezy parameter, C . It is also included in the non-dimensional shear stress, θ . As θ is inversely proportional to the square of the Chezy number, the overall sediment transport will be proportional to the square root of the Chezy number. This means that the specified bed resistance not only effects hydrodynamics but also sediment transport.

5.6 Bed Slope

Sediment transport on transverse inclined bed slopes is an essential process to the development of bed topography of alluvial rivers. Unfortunately, only a very limited number of empirical data are available from real rivers. Some laboratory experiments have been used to investigate the bed slope dependency, see Talmon (1992) and Olesen (1987).

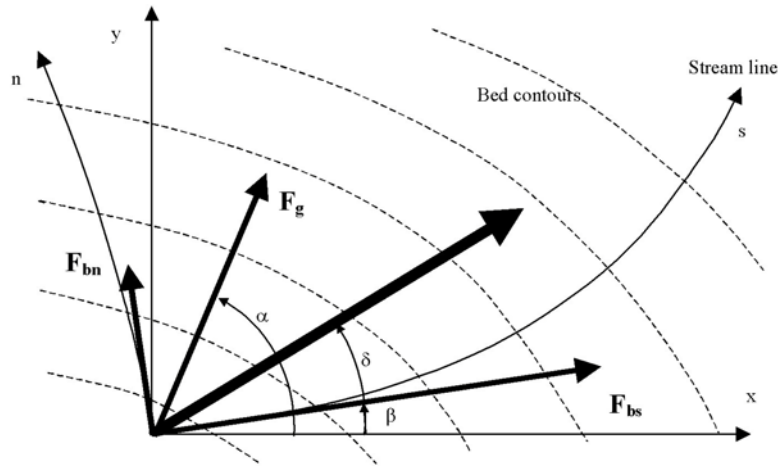

The sediment transport across the stream line is given as:

$$S_n = \left(\tan \delta_s - G \theta^{-\alpha} \frac{\partial Z^*}{\partial S} \right) s_{bl} \quad (5.10)$$

where:

G and α are input parameters

$\tan \delta_s$ is the helical flow strength (computed from the advection-dispersion model).

Bed slope parameters can be specified separately. Various authors suggest the following values:

Engelund-Fredsoe (1982): $G = \frac{1}{1.6}, \alpha = 1$

Kikkawa (1976): $G = 0.6$

Bendegom (1947): $G = \frac{2}{3}, \alpha = 1$

Struikma (1988): $G = \frac{E}{0.85}, \alpha = 0.5$ (Constants; Lab. flume $E=0.5$, prototype $E=1.0$)

Laboratory tests made by Talmon (1992) suggest that the G parameter can differ significantly from one application to another. The range used in his model simulations was between 1 and 3 for $\alpha = 0$. For high values of G , bed topography tends to stabilise itself. For small values of G , bed topography becomes more 'lively' or unstable, corresponding to a braided river.



Bed slope also influences the sediment transport in the longitudinal direction. The sediment transport along the streamline is given as:

$$S_s = \left(1 - e \cdot \frac{\partial z^*}{\partial s}\right) \tag{5.11}$$

where e is longitudinal slope effect parameter (model input).

According to Struiksma (1988) the parameter (e) is related to the resistance number, where:

$$e = \zeta \frac{C^2}{g} \text{ and } \zeta_{0.05} \tag{5.12}$$

Large differences in e can be expected from one application to another. Typically (though not always), values are in the range from 1 to 10.

5.6.1 Hints

The value of G can be found through model calibration. The smaller the value of G , the steeper the bed slope. The value of e will have a similar effect on bed topography stability compared to the value of G , but less.

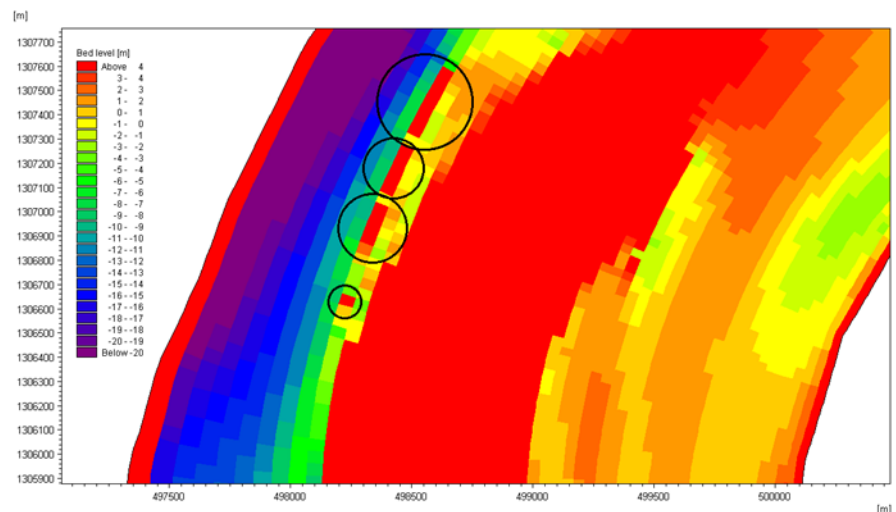

Figure 5.3 Typical example of wiggles (circles) developing on a bar

The bed load vector is allocated on cell faces in the grid, i.e. same locations as the two water fluxes. When calculating the shear stress vector, the default approach is to upwind the water depth in combination with the water fluxes (velocity is flux divided by water depth), which theoretically gives better stabil-



ity in the flow direction. If the upwind water depth is not used, wiggles can result in the flow direction. In the transverse direction upwinding is not necessarily a good idea, as it can cause instabilities.

Two parameters are used for controlling the way the water depth is used:

$hWeightj = 0.5-1$

$hWeightk = 0.5-1$

These are both default 1, but in some cases the transverse bed slope can develop wiggles, as seen in the figure above. For such situations the transverse weighting parameter can be changed from its default value of 1 to e.g. 0.5 to change from upwind water depth (1) to average of the water depths (0.5). For the example above the transverse direction was the k-direction, which meant the following was added to the .M21C input file:

```
[RIVER_MORPHOLOGY_MODULE]
[OPTION_PARAMETERS]
    hWeightj = 1.0
    hWeightk = 0.5
EndSect // OPTION_PARAMETERS
```

The first option is shown for illustration only (it does nothing, as 1 is the default).

5.7 Bottom Update

An option is available to update the bed level at every time-step. If more than one sediment fraction are used, the percentage of each sediment fraction at the riverbed will be updated (i.e. the grain size distribution in the sediment model will be updated).

When the bed level is updated the model becomes morphological. This means that there is feedback between sediment transport and the hydrodynamic conditions. If the expected bed level changes are modest, it is not necessary to run the model morphologically - the model will only show erosion and deposition rates without updating the riverbed. The graded sediment model will, however, still update the grain size distribution.



5.7.1 Bathymetry

When using the morphological model, care must be taken when creating the model bathymetry. (There is a very distinct balance between sediment transport, flow depth, flow velocity, bed resistance and surface slope which has to be found through model calibration.)

Raw bathymetry generated field surveys will usually include all irregularities in the river bed topography, including ripples, dunes and major bed forms. When interpolating a model grid to the bathymetry, where grid spacing can typically be in the range of 50-200 m, it is necessary to remove sub-grid scale irregularities in the measured data. In other words, features finer than the resolution of the selected grid size should not be explicitly included in the model bathymetry. As discussed below, these features should be represented as bed resistance. If this is not done, two things can happen:

1. The morphological model will exhibit too much scatter in the erosion and deposition pattern due to artificial irregularities in the model bathymetry.
2. The morphological model may become unstable due to abrupt changes in bed elevation between adjacent grids.

To remove these sub-grid scale features, the model bathymetry can be smoothed. Alternatively, an initial morphological simulation could be performed to smooth out any small scale irregularities.

The problem of initial bathymetry in a morphological simulation is comparable to a cold start in a hydrodynamic simulation. The difference is the time scales involved - the warm up period required in a hydrodynamic simulation is usually quite short, and any initial oscillations or disturbances are quickly dissipated. In comparison, irregularities in initial bathymetric conditions in a morphological simulation may take a very long time to dissipate.

5.7.2 Bed resistance

Small-scale irregularities in measured bathymetry (due to dunes, ripples, etc.) are incorporated into the model as bed resistance. Dune dimensions may give some information on the bed resistance and especially the seasonal variation in bed resistance. Accurate specification of the Chezy or the Manning number is important to get the correct flow distribution, particularly in shallow regions (such as shallow bars). If the resistance over a bar is too high, too much flow will be deflected and there will be an enhanced tendency towards development of a braided river (bar formations). Therefore, just as the G bed slope parameter is important for bed topography development, so is the bed resistance distribution between deeper and shallower areas.



5.8 Boundary Conditions

5.8.1 General description

Boundary conditions for the hydrodynamic model are discussed separately (see the Reference Manual).

The sediment transport model also requires boundary conditions. In theory only upstream sediment transport boundary conditions are required. However, as the model allows change in flow direction during the simulation, sediment transport has to be specified at all boundaries. Each boundary condition only becomes 'active' during inflow.

For long-term morphological simulations, boundary conditions are very important for the final configuration of the model bathymetry, and should be selected carefully. Three morphological boundary condition types can be specified:

1. bed level change
2. sediment transport
3. suspended sediment concentration

A boundary condition is also required for helical flow. However, a constant value of zero should be used here, which assumes that no helical flow is present at the model boundary.

The boundary condition can be specified in one of the following ways:

- a constant value used throughout the whole simulation. The value is applied at all points along the boundary
- a time series (type 0 data file) which is automatically interpolated to match the simulation time-step. The value is applied at all points along the boundary
- a time series of line values (type 1 data file) which is automatically interpolated to match the simulation time-step. The number of grid points in the data file must match the number of grid points along the open boundary

Regardless of the different ways of specifying boundary values, one boundary condition must be specified for all open boundaries and for all fractions.



5.8.2 Sediment transport

If the actual boundary condition is sediment transport, the specified value must always be positive. The sediment transport direction is the same as the flow velocity and is computed internally.

If a constant value is specified (a constant or a time series) the model will automatically distribute the specified sediment transport in proportion to the local sediment transport capacity:

$$q_{s,i} = Q_s \cdot \frac{q_{s,i}^e}{\sum_{i=1}^n q_{s,i} \cdot \Delta_{X_i}} \quad (5.13)$$

where

$q_{s,i}$ is the actual sediment transport at point i on the boundary line

Q_s is the integrated sediment transport across the boundary

$q_{s,i}^e$ is the sediment transport capacity at point i on the boundary line

n is the number of points along the boundary line

Δ_{X_i} is the spacing between grid points along the boundary

The sediment transport capacity (also called equilibrium sediment transport because sediment transport is in equilibrium with local hydraulic conditions) is calculated automatically by the model.

If a line series is specified, no further distribution of the sediment transport is performed.

There is no distinction between suspended load and bed load when specifying the sediment transport boundary condition. This will be used directly in the sediment continuity equation for calculation of net erosion and deposition. However, the suspended sediment model requires a separate concentration boundary condition when solving the advection-dispersion equation of suspended sediment. This boundary condition is calculated automatically as follows:

$$q_s = q_{s,sus} + q_{s,bed} \quad (5.14)$$

$$C = \frac{q_s - q_{s,bed}}{q} \cdot \rho_s \cdot 10^3$$



where

$q_{s, sus}$ is the actual suspended sediment transport at point i

$q_{s, bed}$ is the bed load sediment transport at point i

C is the concentration of suspended sediment

q is the water flux at point i

ρ_s is the sediment bulk density

The actual bed load transport is always the same as the bed load sediment transport capacity as calculated from the local hydraulic conditions. This means that if a specified boundary condition exceeds the total sediment transport capacity, the extra sediment will be seen as an extra high suspended sediment concentration. When calculating change in bed level, the boundary condition is (as mentioned above) applied directly and no assumption about distribution between bed load and suspended load is necessary.

When more than one sediment fraction is modelled, the sediment transport of each specific fraction must be specified. The model will automatically add up sediment transport of each fraction when changes of the riverbed are calculated.

5.8.3 Bed level change

When the specified boundary condition is a change in bed level, the boundary condition for the advection-dispersion model computing suspended sediment concentration is found in the following way:

$$C = C^e + \frac{\partial z}{\partial t} \cdot \frac{\Delta_y}{86400 \cdot q} \quad (5.15)$$

where

C is the concentration of suspended sediment

C^e is the equilibrium concentration of suspended sediment

$\frac{\partial z}{\partial t}$ is the specified bed level change

q is the water flux at point i

Δ_y is the spacing between grid points across the boundary



This relationship is based on the assumption that bed load transport is always in local equilibrium and sediment continuity is preserved. A specified increase in bed level at the boundary therefore involves an overload of suspended sediment at the boundary. As with the sediment transport boundary condition, the specified value is used directly in the sediment continuity equation and the above formula is only used when specifying boundary conditions for the suspended load sub-model.

When several sediment fractions are included in the model, the bed level change corresponding to each fraction has to be specified. For example, if a total bed level change is 0.1 m/day, with two fractions specified with 70% and 30% of sediment at the boundary, the specified bed level change for each fraction should be 0.07 m/day and 0.03 m/day, respectively.

5.8.4 Hints

As with hydrodynamic model boundaries, boundaries to the morphological model should be located in areas where only modest changes occur. A bed level change boundary is usually the most stable, at least when no change in bed level is specified. In some cases this assumption may not be possible, such as when 'sediment waves' (due to floods, etc.) or bed disturbances are propagating into the model area.

The specified sediment transport should not be too different from the equilibrium sediment transport. This will avoid unrealistically high erosion or deposition rates at the boundary, which may lead to model instability. This is especially the case for a line series of boundary conditions. It is a good idea to make a test simulation using a bed level change boundary (value zero) and let the model compute the equilibrium sediment transport at the boundary.

5.9 Curvilinear Grid

Two files are required to define the curvilinear grid:

1. A grid (2D matrix) describing the coordinates of the four corner points in each computational grid cell
2. A grid (2D matrix) describing the depths (and other features) at the centre of each computational grid cell

This means that the dimension of the curvilinear grid that describes the grid coordinates will be one higher in each direction:

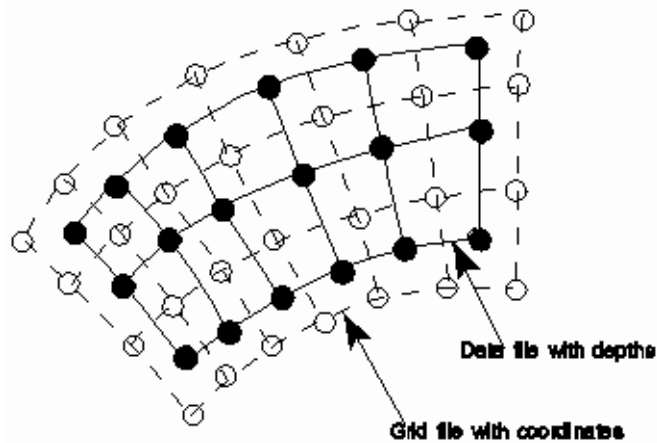

Figure 5.4 Grid coordinates in curvilinear grid

To solve the difference equations in the curvilinear grid, coordinate system orientation is chosen to be parallel with one of the grid lines joining the centres of the grid cells (solid lines in Figure 5.4). The grid lines in this direction are defined as the s -lines. The grid has to be orthogonal, so the direction of the other axis will always be parallel (defined as the n -lines). Scalar functions such as depth (h), denoted H in the curvilinear coordinate system, and vector functions such as the velocity components (u, v), denoted (U, V) in the curvilinear coordinate system, are transformed differently between the two coordinate systems. R_s and R_n denotes the radius of curvature of the s -lines and n -lines respectively at the considered grid point. The transformation is then:

$$\begin{aligned}
 h &= H \text{ and } \frac{\partial h}{\partial x} = \frac{\partial H}{\partial s} \text{ and } \frac{\partial h}{\partial y} = \frac{\partial H}{\partial n} \\
 u &= U \text{ and } v = V \\
 \frac{\partial u}{\partial x} &= \frac{\partial U}{\partial s} - \frac{V}{R_s} \text{ and } \frac{\partial u}{\partial y} = \frac{\partial U}{\partial n} - \frac{V}{R_n} \\
 \frac{\partial v}{\partial x} &= \frac{\partial V}{\partial s} - \frac{U}{R_s} \text{ and } \frac{\partial v}{\partial y} = \frac{\partial V}{\partial n} - \frac{U}{R_n}
 \end{aligned} \tag{5.16}$$

The transformation of a scalar (h) and a vector (u, v) from a Cartesian coordinate system to a curvilinear coordinate system is illustrated in Figure 5.5.

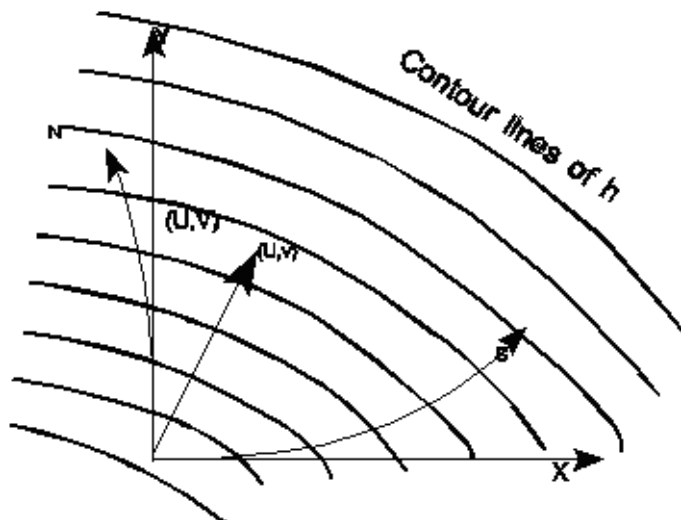

Figure 5.5 The transformation of a scalar (h) and a vector (u,v) from a cartesian coordinate system to a curvilinear coordinate system

The standard MIKE 21 Pre- and Postprocessor tools can be used to analyse and present input and output of the curvilinear model. In line series data files (type T1 data) and matrix series (type T2 data), constant Δx and Δy values of the grid spacing are included in the standard data specification. When using data files from a curvilinear grid, these parameters are meaningless (as the grid spacing varies and the grid point location is specified explicitly) and should be disregarded. By doing this, all basic utilities regarding editing, plotting, reading, printing, etc. can be carried out as usual.

However, there are some differences to be considered when using the MIKE 21 Pre- and Postprocessor:

- Result files, bathymetry, resistance maps, etc. related to a curvilinear grid can be viewed in the Result Viewer (see Chapter 7 MIKE 21C Utilities (p. 181) for more details).
- The curvilinear grid must be generated separately by using the grid generator (m21gg). It is also possible to generate the grid using another grid generator and import it into a MIKE 21 file using the 'Read Matrix Series' utility, or to edit the x and y coordinates directly using the 'Edit Grid Series' in MIKE Zero.
- Discharge calculation in MIKE 21C is done by using the MIKE 21 'Curvilinear Discharge Calculation' tool (see Chapter 7 MIKE 21C Utilities (p. 181) for more details).



5.10 Dispersion Coefficients

5.10.1 General

Dispersion coefficients are specified for the advection-dispersion model, which is used for suspended sediment transport calculations. By using the so-called profile functions in the suspended sediment transport model, some dispersion is implicitly included in the model to represent mixing due to:

- Non-uniform vertical flow and concentration profiles
- Secondary flow (helical flow)

The dispersion coefficients explicitly specified here should be considered as additional dispersion due to other sub-scale phenomena such as sub-scale (less than grid size) turbulence. The values of these coefficients are found through calibration and comparison with observed values of suspended sediment concentrations.

5.10.2 Specifying the dispersion coefficients

The dispersion coefficient can be specified as:

- Constant in space, as a coefficient for the x-direction (streamline direction) and a coefficient for the y-direction
- Two-dimensional maps of coefficients, one for the x-direction and one for the y-direction
- Proportional to the hydrodynamic flow density. With this specification coefficients are calculated at every time-step. Minimum and maximum values should also be specified.

5.10.3 Recommended selection and values

Selecting dispersion coefficients is very difficult. The best way is from a calibration process where simulated and measured suspended sediment concentration fields are compared. Often this is not the case, and empirical estimates have to be used. Many different formulations have been suggested, including:

$$\begin{aligned} D &= K_1 \frac{\Delta x^2}{\Delta t}, K_1 = 0.01 - 0.08 \\ D &= K_2 u \Delta x, K_2 = 0.05 - 0.15 \\ D &= K_3 u^2 \Delta t, K_3 = 0.1 - 0.3 \end{aligned} \tag{5.17}$$



where Δx is grid spacing, Δt is time-step and u is local current speed. The listed range of possible values is based on a typical river application with Δx around 100 m, depth around 10 m and velocity around 1 m/s.

5.10.4 Hints

Values of dispersion coefficient that are too high will cause instabilities. Stability is a function of the local transport Courant number and the dispersion coefficient. For practical applications it is not possible prior to a simulation to judge whether the upper limit of the dispersion coefficient has been reached. If you persist with using a specific value of dispersion coefficient even though you get instabilities, decrease the time-step.

MIKE 21C does not accept all values of dispersion coefficient, since an upper limit can be reached:

$$\left(\frac{D_x}{(\Delta x)^2} + \frac{D_y}{(\Delta y)^2} \right) \cdot \Delta t \leq 0.5 \quad (5.18)$$

The stability criteria given is valid for a pure diffusive problem, but since advective sediment transport is included in normal applications as current fields, the upper limit will be smaller than 0.5. If the stability criterion is violated, the dispersion coefficient will be reduced locally and a warning will be written in the log file.

5.11 Graded Sediment Model

Several fractions of sediment (up to 15) can be specified. In the erosion and deposition of sediment, the percentage of the specific sediment fraction on the riverbed is taken into account.

Sediment transport capacity for each fraction is reduced according to the percentage by mass of that fraction on the riverbed. For bed load, the reduced sediment transport capacity for the i^{th} fraction is given by:

$$S_{bl,i} = S_{bl}(d_i) \cdot \frac{m_i}{\sum_{j=1}^n m_j} \quad (5.19)$$

where

$S_{bl,i}$ is the reduced sediment capacity of the i^{th} fraction

$S_{bl}(d_i)$ is the sediment capacity of the i^{th} fraction



d_i is the grain size of the i^{th} fraction

m_i is the mass of the i^{th} fraction

$\sum_{j=1}^n m_j$ is the mass of all sediment fractions

For the suspended load, the equilibrium concentration of the i^{th} fraction is reduced in a similar way:

$$C_{e,i} = C_e(d_i) \cdot \frac{m_i}{\sum_{j=1}^n m_j} \quad (5.20)$$

The initial sediment distribution on the riverbed (m_i) is model input. The grain size distribution of the bottom sediment is updated continuously by solving the continuity equation for each fraction.

An example of a grain size distribution is provided in Figure 5.6.

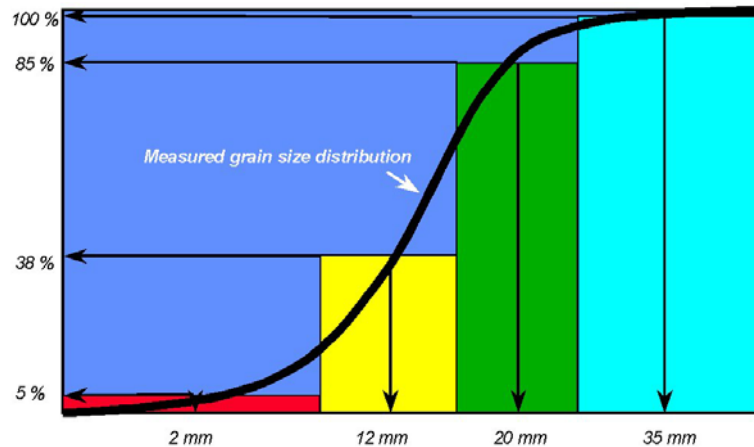

Model parameters

Fraction 1:
Size= 2 mm
Initial amount = 5 %

Fraction 2:
Size= 12 mm
Initial amount = $38-5 = 33$ %

Fraction 3:
Size= 20 mm
Initial amount = $85-38 = 47$ %

Fraction 4:
Size= 35 mm
Initial amount = $100-85 = 15$ %

Figure 5.6 Measured grain size distribution

Boundary and initial conditions have to be specified for each fraction of sediment. If a sediment transport boundary condition is specified, the boundary condition for each particular fraction will be proportional to the percentage of that fraction. For example, if fraction 2 represents 20% of the total sediment composition, 20% of the total sediment boundary condition should be attributed to that fraction. If a bed level change boundary condition is specified, bed level change is specified for each fraction in a similar way. However, if the bed level change is specified as constant zero, the initial bed layer distribution will determine the sediment transport of each fraction at the boundary.

An example of a multi-layer bed model is provided in Figure 5.7.

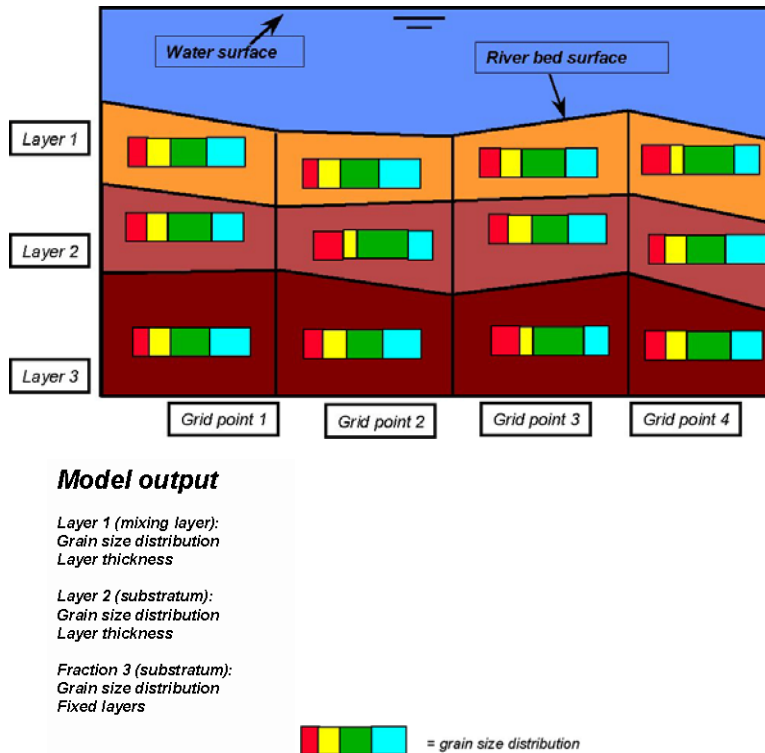

Figure 5.7 Example of multi-layer bed

5.11.1 Hints

Graded sediment should be used when the sediment transport is close to the threshold of initiation of motion of the coarsest material. The sediment grading and armouring effects (to a lesser degree) in the graded sediment model tend to give a better prediction of erosion (among other things) compared to the single fraction model.

5.12 HD Integration

HD Integration refers to parameters that affect the hydrodynamic solution scheme. This means that care should be taken when selecting these parameters as they can change the fundamental structure of the model. There is additional information, discussion and references available in the *Scientific Documentation*.

There are four different Integration Types available:

- **Fully dynamic**
The HD simulation will perform a fully dynamic simulation. This is default.



- **Scaled dynamic**
The simulation will be performed with the HD time-step different to the General time-step. See Scaling Factor and Long-Term Simulations for more information.
- **Quasi-steady**
A quasi-steady approach is required when the selected time-step is too small for the AD simulation to achieve steady state conditions. Further information is available in Time-Step Selection. Also, there are a number of parameters available to control the Quasi-Steady solver - see Quasi Steady Solver Control.

The quasi-steady HD solver is based on an algorithm that is fundamentally different from that used for the fully dynamic solver. This means that the two models will not necessarily give identical results. The quasi-steady solver, based on a CFD solution method that applies the SIMPLER correction scheme, originates from incompressible fluid mechanics. See the *Scientific Documentation* for more information.

- **Steady**
This is for special circumstances where a completely steady flow field is applied, read from the hotstart file.

There are Special options available, under OPTION_PARAMETERS, HYDRODYNAMIC_MODULE:

- **qs_gpr = TRUE**
When activated, details on the progress of the solution are written to a log file, including information on iterations, convergence and ranges of the individual parameters. Default value is FALSE.
- **s_relax = value between 0 and 1**
This is an under-relaxation parameter for the pressure term. When frequent non-convergence of the continuity equation occurs, this parameter can be used to slow down development of the pressure field. This can be useful in cases with fast hydrographic changes. The default value is 1.

5.13 Helical Flow

Helical flow is a secondary flow phenomenon in rivers. Whilst it generally does not have a strong influence on general flow patterns in rivers with large width/depth ratios, it can have a significant influence on sediment transport direction and hence morphological changes. Helical flow is the driving force for bend scour and plays an important role in confluence scour and char build-up and migration.

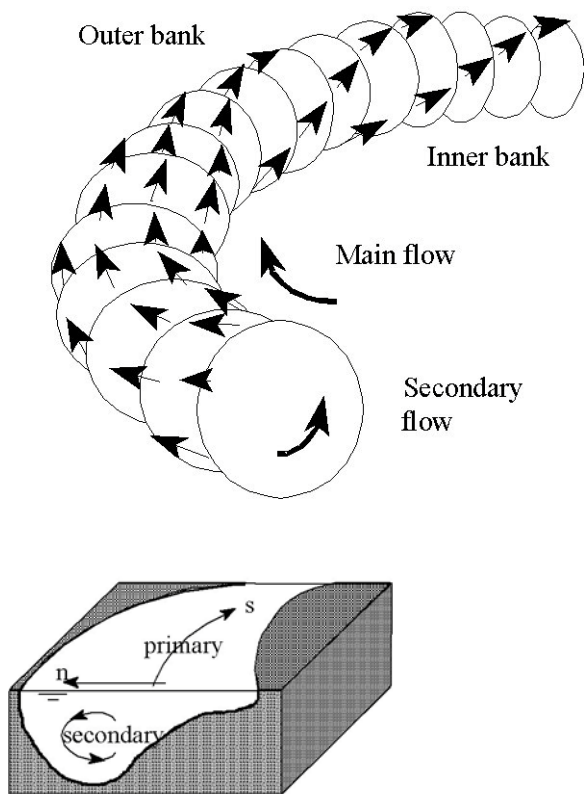

Figure 5.8 Helical flow

5.13.1 Theoretical background

The helical flow pattern occurs in regions of curved flow, particularly river bends. It arises from an imbalance between pressure gradient and centripetal acceleration exerted on water moving along a curved path. Near the bed, helical flow is directed towards the centre of flow curvature. The magnitude of helical flow (the transverse flow velocity component) rarely exceeds 5-10% of the main flow velocity in natural rivers.

The magnitude of the equilibrium secondary flow is proportional to flow depth and inversely proportional to the radius of curvature of the main stream line. This has been defined by de Vriend (1981):

$$i_s = u \cdot \frac{h}{R_s} \quad (5.21)$$



where:

u is the main flow velocity

R_s is the radius of curvature of streamlines

i_s is the helical flow intensity

This yields a bed shear stress direction given by

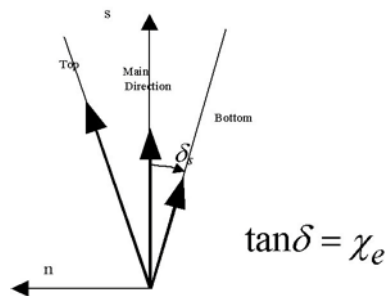

$$\tan \delta_s = \beta \cdot \frac{h}{R_s} \quad (5.22)$$

where:

δ_s is the angle between the bed shear stress and depth averaged shear stress (or flow)

β is defined as:

$$\beta = \alpha \cdot \frac{2}{\kappa^2} \left(1 - \frac{\sqrt{g}}{\kappa C} \right) \quad (5.23)$$

where:

κ is the von Karman constant, 0.4

g is the gravity, 9.81 m/s²

C is the Chezy number

α is a calibration constant (model input)



5.13.2 Recommended value

Theoretical values of β can be obtained from theoretical velocity profiles. They exhibit some scatter depending on what kind of profile is assumed. Measurement of the near bed flow direction is almost impossible due to migrating bed forms. The best value of β is obtained by calibration of the morphological model. According to Olesen (1987), β is in the range 4 - 12. This means that the model input parameter α is in the range 0.4 to 1.2 for a Chezy roughness of 40 m^{1/2}/s. α can be specified as a global constant or as a two-dimensional varying parameter.

5.13.3 Hints

As mentioned above, the effect of the helical flow is important in simulating sediment movement and morphology in river bends. This can be tested by excluding the helical sub-model from the simulation.

If a model region undergoes wetting and drying during a simulation, instability of the helical flow model can occur due to the rapid changes in stream line curvature. Helical flow in shallow areas is rarely important for morphological development. As such, in specific grid points where instabilities occur and where helical flow is unimportant it is recommended that α is set to zero.

5.14 Hot Start

5.14.1 General

A simulation can start from no-flow conditions (a 'cold start') or can be restarted from a previous simulation (a 'hot start'). In the latter case information from the previous simulation is saved for use later. This information is called 'hot data'.

Preparation of hot data is specified in the *Output Specification*. Use of hot data is specified in the model specifications under *Initial Conditions*. A separate hot data file is required for hydrodynamics and sediment transport. It is possible to hot start the hydrodynamic model and cold start the sediment transport model, or vice versa.

5.14.2 Hydrodynamics

Specification of a hydrodynamic hot start file for the curvilinear model is similar to the standard **MIKE 21 hydrodynamic model**. The hot start file prepared in a previous simulation contains specific model information such as hydrodynamic time-step, starting time and flood and dry parameters. It is possible to change these parameters without regenerating the hot start file by manually editing the first item (called 'miscellaneous') in the hot data file (so-called T2 type file) using the standard matrix file editor in MIKE 21 PP.



5.14.3 Sediment transport

The initial conditions required for the sediment transport model are local strength of helical flow and suspended sediment concentration (each fraction). Bed load, calculated explicitly and independent of the previous time-step result, does not require initial conditions.

5.14.4 Morphological model

If bed level update is included, the hydrodynamic hot data file will contain the last updated bathymetry and sediment. The accumulated erosion/deposition, which is calculated and stored by the sediment transport model, is not updated. This should not effect model results.

5.14.5 Hints

Calculation of helical flow uses the curvature of flow stream lines. If the model starts from zero-flow conditions (cold start) this may cause problems. Therefore, it is recommended to always use a hydrodynamic hot start before the sediment transport model is activated. Alternatively, the simulation time for the sediment transport model can be specified to start later than the hydrodynamic model (say after 200 HD time-steps).

5.15 Hydrodynamics

The MIKE 21C curvilinear hydrodynamic model is very similar to the standard MIKE 21 hydrodynamic model. MIKE 21C is different in the equations (the differential equations in MIKE 21 are solved using a Finite Difference scheme), where Δx and Δy in all equations are substituted by $\Delta s_{j,k}$ and $\Delta n_{j,k}$, where (j,k) denotes grid location and Δs and Δn are grid spacing at that grid location in the j and k directions. Additional terms are also included in the momentum equations due to the grid line curvature, described in the Scientific Documentation.

The x and y coordinate of each grid point in the curvilinear grid is an additional input requirement, defined in a 2D matrix file. As a result of the modifications and additional terms in the governing equations the curvilinear model is a slower than the standard MIKE 21 model. However, the curvilinear model

has advantages, including resolution of model boundaries (including land), bathymetric definition and a more variable grid structure.

$$\frac{\partial H}{\partial t} + \frac{\partial p}{\partial s} + \frac{\partial q}{\partial n} - \frac{q}{R_s} + \frac{p}{R_n} = 0 \quad (5.24)$$

$$\frac{\partial p}{\partial t} + \frac{\partial}{\partial s} \left(\frac{p^2}{h} \right) + \frac{\partial}{\partial n} \left(\frac{pq}{h} \right) + 2 \frac{pq}{hR_n} + \frac{p^2 - q^2}{hR_s} + gh \frac{\partial H}{\partial s} + \frac{g}{C^2} \frac{p \sqrt{p^2 + q^2}}{h^2} = RHS$$

$$\frac{\partial q}{\partial t} + \frac{\partial}{\partial s} \left(\frac{pq}{h} \right) + \frac{\partial}{\partial n} \left(\frac{q^2}{h} \right) + 2 \frac{pq}{hR_s} + \frac{q^2 - p^2}{hR_n} + gh \frac{\partial H}{\partial n} + \frac{gq}{C^2 h^2} \sqrt{p^2 + q^2} = RHS$$

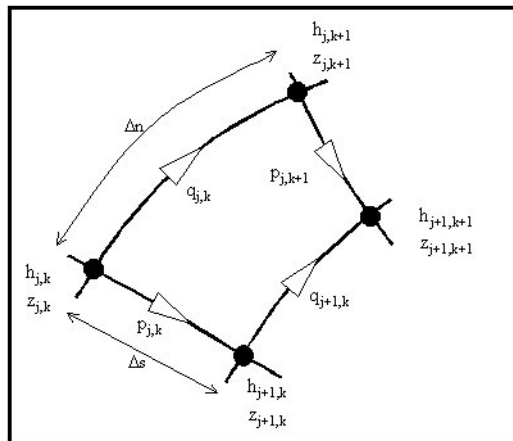

5.16 Initial Conditions

5.16.1 General

Initial conditions for the sediment transport model comprise helical flow strength and suspended sediment concentration for each sediment fraction. The initial bed level change is assumed to be zero. The initial bed level is identical to model bathymetry - for a cold start this means the data in the bathymetry file, and for a hot start (from a morphological simulation) this means the updated bathymetry stored in the hot data file.

5.16.2 Helical flow

The present version of the model will overwrite the user-specified initial conditions for helical flow and set them explicitly to zero. Experience has shown that for a cold start no helical flow is the best starting value. For a hot start,



the model will read the initial helical flow strength data directly from the hot data file.

5.16.3 Sediment transport

The suspended load model requires an initial condition of the suspended sediment concentration for the advection-dispersion model. It can be specified in three ways:

1. As a constant value (cold start)
2. As a space-varying value in a separate dfs2 data file (cold start)
3. From a hot data file (hot start)

For a cold start, it is a good idea to start with a zero initial concentration. Bed load, calculated explicitly and independent of the previous time-step result, does not require initial conditions.

5.17 Long-Term Simulations

Morphological modelling usually requires long-term simulations, (simulations covering years rather than weeks). For such conditions a quasi-steady approach can be applied for the hydrodynamic conditions to speed up simulations which would otherwise be very time-consuming. There are two limiting conditions:

- the requirement of quasi-steadiness in hydrodynamics
- the observance of sediment transport Courant criterion.

There are two options available:

1. Scaled dynamic
2. Scaling factor

In both cases, automatic time scaling using the option **cauto** is available, see *Options*. With this parameter, intermediate time-steps are automatically skipped if the sediment transport Courant criterion permits (the maximum Courant number is defined as **cauto**). With this option it is impossible to control time scaling and the requirement of quasi-steadiness can easily be violated without knowing it. Therefore **cauto** should only be used for steady HD boundaries or at least for very slowly varying HD boundaries.

5.17.1 Scaled dynamic

Marching in time is controlled by Δt , defined in the specification file (or hot start file, if a HD hot start file is used). The time resolution of the hydrodynamic equations is usually also controlled by Δt . However, a different time-



step in the hydrodynamic scheme can be applied using the parameter `dt_hd` (see Options). If `dt_hd` is set to be less than Δt a time scaling factor equal to $\Delta t / dt_hd$ is applied. This means that the simulated time series appears compressed in time. Obviously, this approach is only valid if the boundary conditions vary very slowly in time and that quasi-steady conditions can be assumed. The sediment transport time-step becomes $\Delta t \cdot N_{STHD}$, where N_{STHD} is the number of HD time-steps for each ST time-step. With option 1, the Scaling factor must be unity.

5.17.2 Scaling factor

A scaling factor can be explicitly defined, so the sediment transport time-step becomes $\Delta t \cdot N_{STHD} \cdot \text{Scale_factor}$. With this approach, the description of time varying HD boundaries will be violated due to the time scaling. To compensate, the time scale of the boundary time series should be changed to correspond to the same scaling factor (in other words, `dt` in the boundary condition should be divided by the scale factor). Usually, option 2 is only used for steady (time-constant) boundary conditions. Note that the result file will also have the wrong time scale and should be corrected after the simulation (`dt` in the result file should be multiplied by scale factor). See also Scaling Factor (p. 95).

5.18 Model Specification File

The User Interface creates the model simulation file. This file, which has an extension “.M21C”, is in ASCII format. This means that the file can be opened and edited manually, using a text editor such as “WordPad” or “Notepad”. If convenient, the entire simulation can be specified using a text editor.

The layout of the specification file is in a format called “.pfs” (parameter file system). This is the common format used in many MIKE Zero applications. The format is comprised of sections and keywords. An example is shown in Figure 5.9.

```
[OPEN_BOUNDARY]
  Number_Of_Boundaries = 2
  Default_Position = 1
  [BOUNDARY_1]
    First_Point = 0, 1
    Last_Point = 0, 3
  EndSect // BOUNDARY_1

  [BOUNDARY_2]
    First_Point = 139, 1
    Last_Point = 139, 3
  EndSect // BOUNDARY_2

EndSect // OPEN_BOUNDARY
```

Figure 5.9 Example of section in pfs file



This portion of a MIKE 21C simulation file contains information about the locations of boundary conditions. In other words, the section [OPEN_BOUNDARY] contains a number of keywords relating to boundary condition locations. Examples of keywords include Number_Of_Boundaries and Default_Position. Further, there are two sub-sections listed: [BOUNDARY_1] and [BOUNDARY_2]. Both sub-sections also contain keywords, for example First_Point. Note that each section terminates with a EndSect // line.

Generally, there is no need to access the specification files in this manner; the MIKE Zero interface is available. However, experienced users with fast keyboard fingers and slow mouse hands may prefer to operate the model via a text editor.

Furthermore, there are a number of additional options available in MIKE 21C that are not accessible from the MIKE Zero interface. These options, which are described in Optional Parameters, are not included in MIKE Zero because they are rarely used.

Under each **MODULE** section (for example [HYDRODYNAMIC_MODULE] and [RIVER_MORPHOLOGY_MODULE]) there is a sub-section titled [OPTION_PARAMETERS]. This sub-section is the location for inserting any optional parameters into the specification file.

5.19 Morphological Control Parameters

There are a number of steering parameters for the morphological model. Default values are provided, but for advanced use of the model, modifications of these parameters may be necessary. A brief description is given below:

- **Limit on Helical Flow**
Large spikes in the computed helical flow strength may occur in shallow areas where flow velocity is nearly zero and where sediment transport is also almost zero. This parameter specifies the upper limit of the helical flow strength ($\tan \delta_s$) to avoid instability in the model.

5.20 Mud, Debris or Oil

The 'Mud, Debris or Oil' feature enable an alternative hydrodynamic solution in which a fluid dependent flow resistance is added to the standard flow momentum equations.

Naef et al (2006) defines a number of formulations for calculating flow resistance relations and the flow resistance term; τ_0/ρ . The current implementation include a 'Full Bingham' relation, which in addition allows for applying simpler resistance formulations which excludes the Bingham viscosity term (e.g. the 'Turbulent and Yield' relation as defined in Naef et al (2006)).



The full Bingham flow resistance relation determine the flow resistance term ($\tau_0/\rho gh$) from the following third order equation (see Naef et al, 2006):

$$2\tau_0^3 - 3\left(\tau_y + 2\frac{\mu_B q}{h^2}\right)\tau_0^2 + \tau_y^3 = 0 \quad (5.25)$$

where q is the flux (discharge per unit width), h is the fluid depth, τ_y is the yield stress and μ_B is the Bingham fluid viscosity.

The third order equation is solved numerically during the simulation to give τ_0 as function of the yield stress (τ_y), Bingham viscosity (μ_B), water depth (h) and flux (q).

Note, that it is possible to activate e.g. the Turbulent and Yield resistance formulation by simply setting the Bingham Viscosity parameter, μ_B , equal to zero.

5.20.1 Recommended values

The rheological properties of non-Newtonian fluid are driven by the complex interaction of a fluid's chemical and material composition. Key composition properties include the particle size distribution (e.g. percent fines), solids concentration, water content, chemical composition, and mineralogy such as the presence of clay minerals.

The Bingham rheological model is well suited for homogenous fluid mixtures with high concentrations of fine particles (e.g. mudflows, hyper-concentrations of fine sand, silt, and clay-size sediment) and other material types such as oils.

The key parameters for the Mud/Debris/Oil model are the following (default unit shown in brackets):

Fluid density:	Density of the fluid mixture [kg/m ³]
Yield Stress:	Shear stress threshold that needs to be exceeded for the fluid to flow [Pa]
Dynamic viscosity:	Dynamic viscosity of the Bingham fluid mixture [PS s]

Fluid density

The fluid density can be determined from either measurements of the fluid to be modelled or calculated using the solids concentrations of the fluid mixture.



Yield Stress

Ideally, the yield stress (i.e. yield strength) of the fluid to be modelled can be determined from rheograms developed from viscometric measurements in a laboratory. A rheogram relates the shear rate of the fluid to the applied shear stress. A commercially available concentric cylindrical viscometer is ideally suited for this type of analysis because it is capable of developing the rheogram for a wide shear rate range. However laboratory derived rheological analyses may not always be possible or practical.

Yield stress can also be determined empirically from both case studies involving similar fluid compositions and empirical relationships. For hyper-concentrations composed of fine sediment, yield stress is often formulated as a function of material type (e.g. clay mineralogy) and sediment concentration. Julien (2010) provides the following recommended empirical relationships for yield stress as a function of sediment concentration for a variety of material types using this exponential form:

$$\tau_y = a \cdot 10^{b \cdot C_v} \quad (5.26)$$

where τ_y is the yield stress [Pa], a and b are coefficients (see Table 5.1) and C_v is the volumetric sediment concentration.

Table 5.1 Coefficients for yield stress empirical relationships from Julien (2010)

Material	a	b
Bentonite (montmorillonite)	0.002	100
Sensitive clays	0.3	10
Kaolinite	0.05	9
Typical soils	0.005	7.5

Oils are a special application where the yield stress is typically set to zero and the dynamic viscosity dictates the laminar flow nature represented by the Bingham rheological model. For zero yield stress the Bingham fluid model is valid for laminar depth-integrated flow.

Note that the typical exponential relationship between yield stress and sediment concentration indicates that at some point small changes in concentrations can dramatically change yield stress. This is an important dynamic sensitivity to consider when evaluating Bingham fluids.

Dynamic viscosity

Once the fluid is in motion, the dynamic viscosity (i.e. plastic viscosity) represents how the fluid flows under applied shear stresses. Similar to yield stress, the dynamic viscosity can be determined from rheograms developed from

viscometric measurements in a laboratory. However laboratory derived rheological analyses may not always be possible or practical.

Dynamic viscosity can also be determined empirically from both case studies involving similar fluid compositions and empirical relationships. Julien (2010) provides the following recommended empirical relationships for yield stress as a function of sediment concentration for a variety of material types using this exponential form:

$$\mu_m = 0,001 \cdot 10^{c \cdot C_v} \quad (5.27)$$

where μ_m is the dynamic viscosity [Pa s], c is a coefficient (see Table 5.2) and C_v is the volumetric sediment concentration.

Table 5.2 Coefficients for dynamic viscosity empirical relationships from Julien (2010)

Material	c
Bentonite (montmorillonite)	100
Sensitive clays	10
Kaolinite	9
Typical soils	7.5

For modelling viscous, low-strength fluids such as oils, the dynamic viscosity is the key parameter for the Bingham model as the yield stress is often set to zero. The dynamic viscosity for such materials is best determined from rheograms developed from viscometric measurements in a laboratory, e.g. commercially available concentric cylindrical viscometer. Available literature (e.g. product descriptions) and case studies for commercially derived materials are other appropriate sources for choosing the value for the dynamic viscosity parameter.

5.21 Optional Parameters

A number of optional parameters can be specified in a model simulation. This is done by manually inserting additional lines directly into the MIKE 21C input file. For more information regarding the format of the MIKE 21C input file, see Model Specification File (p. 86).

In each **MODULE** section (for example [**HYDRODYNAMIC_MODULE**] and [**RIVER_MORPHOLOGY_MODULE**]) there is a sub-section titled [**OPTION_PARAMETERS**]. This sub-section is the location for inserting any optional parameters into the specification file.



For example, to modify the parameter QS_GPR in the hydrodynamic module to TRUE, enter the line in red:

```
[HYDRODYNAMIC_MODULE]
[OPTION_PARAMETERS]
  QS_GPR = TRUE
EndSect // OPTION_PARAMETERS
...
...
```

To modify the parameter VISC in the river morphology module to 0.000001 (which is actually the default value), enter the line in red:

```
[RIVER_MORPHOLOGY_MODULE]
[OPTION_PARAMETERS]
  VISC = 0.000001
EndSect // OPTION_PARAMETERS
...
...
```

5.21.1 Hydrodynamic optional parameters

- **QS_GPR = TRUE (default = FALSE)**
Forces detailed output of the linear equation solution to the log file when the quasi-steady HD solver is activated. Can be very useful for adjusting the control parameters.
- **S_RELAX = number between 0 and 1 (default = ???)**
Under relaxation of pressure update. Can be useful if there are oscillations in time in the pressure field or stability problems.

5.21.2 Morphological optional parameters

- **VISC = viscosity (default = 10-6)**
The laminar viscosity is used for calculation of the settling velocity for the sediment.
- **BEQUIHEL = TRUE (default = FALSE)**
The helical flow adaptation in space is ignored. The helical flow is set equal to its local equilibrium value. This can save time in some simulations. The helical flow adaptation is relatively weak (short adaptation length scale), but it is usually included as it provides better stability.

- BANK_FRACTION = number between 0 and 1 (default = 1)**
 Specify a fraction of the bank material that is sand. Default is that bank material consists entirely of the same material that is also on the riverbed. The sand fraction in the eroding bank only influences the erosion products that are entered to the riverbed when a bank is eroded. It does not directly influence bank erosion.

5.22 Profile Functions

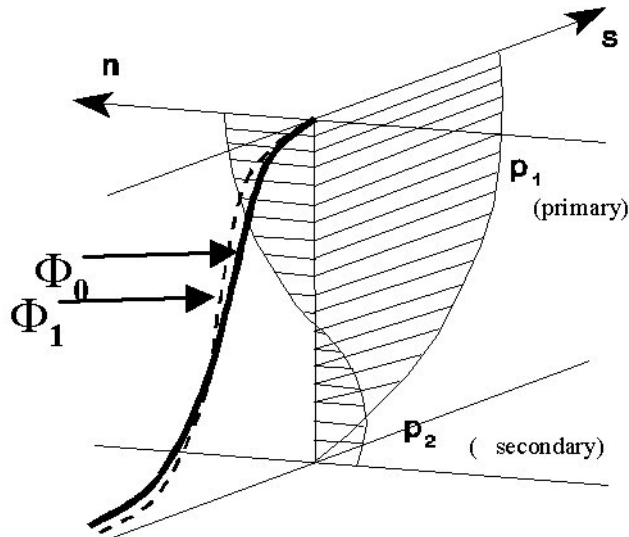

Figure 5.10 The shape of the concentration profile when calculating suspended sediment transport

When calculating suspended sediment transport, the shape of the concentration profile $\varphi(\zeta)$ and the velocity profile $\rho(\zeta)$ is taken into account:

$$Q_s = \int_0^h cU dz = h \int_0^1 c(\zeta)U(\zeta)d\zeta = h\bar{U}\bar{C} \int \varphi(\zeta) \quad (5.28)$$

The concentration profile depends on the Rouse number (the fall velocity and the shear velocity) and the velocity profile depends on the local bed roughness.

Based on Galappattis theory for profile functions ($\varphi(\zeta)$), profile shape also depends on spatial and temporal changes in the concentration. During erosion, for instance, the concentration near the water surface tends to be less than in the equilibrium profile because the sediment is moving upwards in the water column. This delay in response of concentration of suspended sedi-



ment is referred to as the time and space lag in sediment transport. An advection-dispersion model is applied to solve Galappattis profile functions.

Secondary flow gives rise to a deviation of the mean sediment transport direction because the concentration of suspended sediment is non-uniformly distributed over the depth. Therefore, profile functions of the secondary flow are also established.

By including profile functions in the sediment transport equations, some three-dimensional effects have been included. The delay in response of suspended sediment tends to damp the disturbances of the bed topography. For the same reason, it is more common to observe instability in a model without suspended load compared to a model with. Accurate description of river bend scour requires that helical flow is included, as this is the driving force.

The profile functions are described in more depth by *Galappatti* (see Section 5.34) and in the *Scientific Documentation*.

5.23 Quasi Steady Solver Control

HD Integration refers to parameters that affect the hydrodynamic solution scheme. This means that care should be taken when selecting these parameters as they can change the fundamental structure of the model. There is additional information, discussion and references available in the *Scientific Documentation*.

The parameters controlling the limits on the quasi-steady simulation are:

- **Momentum - Time-step**
The time-step for solution of the dynamic momentum equations. A time-step is required as the equations are non-linear. This time-step can be of a similar order of magnitude as the HD time-step that would be selected for a fully dynamic HD simulation.
- **Momentum - Parameter**
This is a relaxation parameter for the selected equation solver. If using the Line SOR solver, over relaxation is typically between 1 and 1.5 (1.2 is recommended). If using the SSIP solver, relaxation is typically between 0 and 1 (0.8 is recommended). To assess the influence of the relaxation parameter, an option is available to print a log of solution progress (**qs_gpr = TRUE**, discussed in HD Integration). Note that high values of this parameter can cause the linear equations to diverge.
- **Momentum - Stop criterion**
This is the stop criterion used for the momentum equations. A value of 10^{-8} - 10^{-6} is recommended.



- **Momentum - Max Iterations**
The maximum number of iterations used for the momentum equations. At least 4 iterations of the momentum equations are recommended to ensure convergence.
- **Momentum - Solver**
The Line SOR solver solves the momentum equations with line implicit successive over relaxation. The SSIP solver solves the equations with Stone's Strongly Implicit Procedure, see *Scientific Documentation* and *Stone, 1968* (Section 5.34). The Line SOR solver is typically applied to the momentum equations as it is convection dominated.
- **Pressure - time-step**
The time-step used for solution of the continuity equation. If the momentum time-step is the same as the pressure (continuity) time-step, the quasi-steady solver will perform much like a dynamic solver. If the pressure time-step is larger than the momentum time-step, the solver becomes quasi-steady. The magnitude of the time-step depends on the specific model, and sensitivity analysis is recommended. In some cases the pressure time-step can be as high as 1 hour, and in other cases not significantly higher than the momentum time-step. To ensure the validity of the quasi-steady approach, phase difference can be measured between simulated water levels and boundary conditions. For a long river reach, water level predictions in the model may be delayed relative to the boundary conditions. If this occurs it may be necessary to reduce the general time-step, which may be too large compared to the HD time-step.
- **Pressure - Parameter**
Same as for the momentum equation parameter.
- **Pressure - Stop criterion**
Same as for the momentum equation parameter.
- **Pressure - Max Iterations**
The maximum number of iterations used for the pressure equation. It is recommended to allow at least 10 iterations of the pressure equation.
- **Pressure - Solver**
As for the momentum equation, the Line SOR solver solves the momentum equations with line implicit successive over relaxation. The SSIP solver solves the equations with Stone's Strongly Implicit Procedure (see *Scientific Documentation*). The SSIP solver is typically applied as the equation is fully elliptic. However, in many cases the pressure equation can be solved with sufficient speed and accuracy with the Line SOR method.



5.24 Scaling Factor

The morphological time scale is usually much longer than the hydrodynamic time scale. Therefore, the model offers the possibility to assume quasi-steady hydrodynamic conditions and to simulate a 'compressed' time event (such as a one year hydrograph). The model will multiply all calculated erosion and deposition rates with this scaling factor when updating the bed level.

The procedure is as follows:

1. Prepare the time series boundary files as usual. Change the time-step in the data file by using the MIKE 21 PP, Data Utilities:

$$\Delta t_{data, scaled} = \frac{\Delta t_{data}}{sf}$$

2. Specify the same scaling factor sf in the model specification file and reduce the total simulation time:

$$\sum t_{data, scaled} = \frac{\sum t_{data}}{sf}$$

3. Execute the model with the reduced simulation time and reduced time-step for data storage in the boundary files.

Change the time-step in the result data file (matrix series with sediment transport, bed level changes, etc.) by using the MIKE 21 PP, Data Utilities:

$$\Delta t_{result} = \Delta t_{resultscaled} sf$$

The scaling factor should be chosen so that the sediment transport time-step becomes reasonable and the Courant number criteria using bed wave celerity is fulfilled.

5.25 Sediment Characteristics

5.25.1 Sediment transport

MIKE 21C models **non-cohesive** sediment transport (however, one cohesive sediment component can also be selected). Two modes of sediment transport are described:

1. bed load transport
2. suspended load transport



A third category is normally referred to as wash load. Presently, the model does not simulate wash load.

The model has three options for sediment transport calculations:

1. bed load only (or total load) - see Bed Load (*p. 61*)
2. suspended load and bed load
3. suspended load only - see Suspended Load (*p. 110*)

To use a total load model, specify a bed load model and switch off the suspended load model.

Analysis of available sediment data should be used to decide which sub-model to run. For both bed load and suspended load the same information on sediment characteristics are required:

- grain size
- fall velocity
- porosity
- sediment density

Information is also provided on the available Sediment Formulae (*p. 98*).

5.25.2 Grain size

The sediment grain size can be specified in two ways:

1. a constant value
2. a space-varying value specified in a type 2 (grid) data file

When the graded sediment is used (more than one sediment fraction), the grain size for each fraction must be the same across the entire model area. The mean grain size at each grid point is then determined by the initial bed layer composition, which must also be specified when using the graded sediment model.

When using a single sediment fraction, the grain size is regarded as a representative grain size for a specific grid point in the modelling area. This means it can vary spatially. In river bends, coarser sediment is often found in deeper parts of the cross-section while finer sediments are found along the inner banks. If a single sediment fraction is used in the sediment model, it is still a good idea to perform test runs with a multi-fraction model to assess how the sediment will be graded, especially field data on grain size is scarce. A representative grain size map can then be produced using information from these test simulations.



An example of a grain size distribution for a graded sediment model is provided in Figure 5.11.

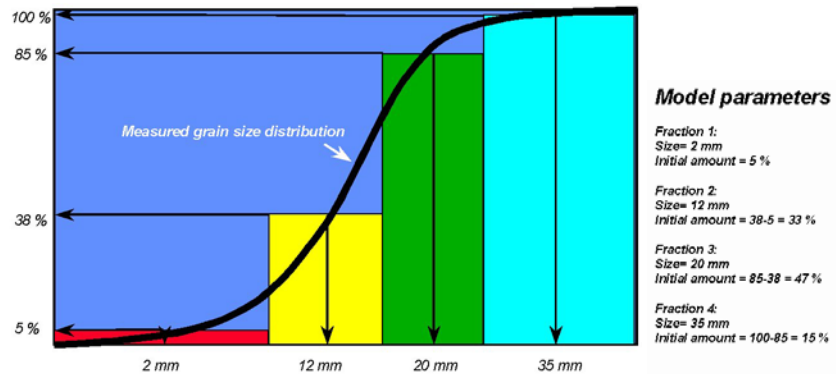

Figure 5.11 Example of grain size distribution for graded sediment model

5.25.3 Fall velocity

The fall velocity of the sediment grains is computed using **Stokes** law for finer sediment and modified formulas (see van Rijn, 1984, Section 5.34) for coarser sediment. For fine sediments ($d < 0.1$ mm):

$$w_s = \frac{(s-1)gd^2}{18\nu} \quad (5.29)$$

For coarse sediment ($0.1 < d < 1.0$ mm):

$$w_s = \frac{10\nu}{d} \left\{ \left[1 + \frac{0.01(s-1)gd^3}{\nu^2} \right]^{0.5} \right\} \quad (5.30)$$

For coarse sediment ($d > 1.0$ mm):

$$w_s = 1.1 \cdot [(s-1)gd]^{-0.5} \quad (5.31)$$

Fall velocity influences the suspended sediment concentration profile and the space and time lag between local sediment transport capacity and the actual sediment transport. A low fall velocity (fine grains) will create a large space and time lag, which should be included in the advection-dispersion model. For a higher fall velocity (coarser sediment) there will be less variation. The time scale for erosion and deposition is of the order of h/w_s , where h is the water depth. A corresponding spatial scale given a certain flow velocity (u) is $L = uh/w_s$, which can be compared to the actual grid spacing.



5.25.4 Porosity

The porosity (n) of the bottom sediment is used in the sediment continuity equation:

$$(1 - n) \frac{\partial z}{\partial t} \cdot \Delta x \Delta y = \frac{\partial S_x}{\partial x} + \frac{\partial S_y}{\partial y} \quad (5.32)$$

It should be based on field measurements, but is usually in the range of 0.3 - 0.7.

5.25.5 Sediment density

The bulk density of sediment (normally considered as a relative density compared to water density) is employed in various *sediment transport formulae*. It is also used to convert suspended sediment transport in g/s/m to suspended sediment transport in m²/s.

For quartz mineral (sand) the relative density (s) is around 2.65, which corresponds to an absolute density of 2,650 kg/m³. Normally, s is in the range of 2 to 3.

5.26 Sediment Formulae

Presently, seven different sediment formulae are implemented in the model:

1. Engelund-Hansen
2. van Rijn
3. Engelund-Fredsoe
4. Meyer-Peter and Muller
5. Empirical formulation (Smart and Jaeggi)
6. Yang for sand
7. Yang for gravel

The *Scientific Documentation* contains additional descriptions of these formulae. The expression for the empirical relation, which is a universal formula:

$$\varphi = a_1 \left[\left(\frac{d_{90}}{d_{30}} \right)^{a_1} /^{a_3} C^{a_4} \theta^{a_5} \cdot [a_6 \theta^{a_7} - \theta_c]^{a_8} \right] \quad (5.33)$$

The bed load and suspended load formulae are the same, but different parameters can be specified. A number of known formulae can be designed with this formulation (the Meyer-Peter is defined by $a_1=8$, $a_2=0$, $a_3=0$, $a_4=0$,



$a_5=0$, $a_6=1$, $a_7=1$, $a_8=1.5$ and Smart-Jaeggi by $a_1=4$, $a_2=0.2$, $a_3=0.6$, $a_4=1$, $a_5=0.5$, $a_6=1$, $a_7=1$, $a_8=1$).

Slope (I) can be either the bed slope or water surface slope. Non-dimensional shear stress (θ) can be either total shear stress θ or skin friction shear stress θ' . Normally, the skin friction is applied for bed load formulas.

Although some of the formulae (e.g. Engelund-Hansen) are total-transport expressions, it is still possible to use them as separate bed load and suspended load models by using bed load and suspended load calibration factors. A choice of sediment formulae is given for both bed load and suspended load, so it is possible to specify different models for each (for instance van Rijn for suspended load and the Engelund-Fredsoe model for bed load).

5.27 Sediment Transport Model Time-Step Selection

The sediment transport time-step is usually much larger than the hydrodynamic and advection-dispersion time-steps. The sediment continuity equation is solved using an explicit scheme and as such the Courant number must be less than 1:

$$\Delta t_{ST,max} = \Delta x \cdot \frac{C_{r,ST}}{c_{ST}} \quad (5.34)$$

Δt is the maximum sediment transport time-step, C_r is the Courant number and c is the celerity of bed form waves.

A maximum permitted value of the Courant number can be specified, see river bed layers under *Morphological Update*. By specifying this, the sediment transport time-step is constantly modified to ensure that the Courant number does not exceed this value.

This is a particularly useful tool for two reasons:

- Sediment transport simulations can be optimised in terms of computational time
- Numerical stability of the solution is guaranteed

5.28 Simulation Time

Simulation time is specified as a total number of time-steps n for the hydrodynamic model. Multiplying this with the hydrodynamic time-step Δt gives the total simulation time.

For the sediment transport model, simulation time is specified from a start time-step in the hydrodynamic model to an end time-step. If cold start is

applied, it may be beneficial to let the sediment transport model start at a later time-step than the hydrodynamic model, which will permit it to 'warm up'.

If using a scaling factor, total simulation time is the number of time-steps multiplied by the actual time-step, multiplied by the scaling factor ($n \cdot \Delta t \cdot \text{scaling_factor}$). As mentioned under *Scaling Factor*, the time-step in the stored results has to be manually multiplied by the scaling factor in the MIKE 21 PP in order to get the right time-step.

5.29 Space Step Selection

Selection of grid spacing should ensure the model bathymetry is representative of the real bathymetry. An important length scale is the adaptation length for friction flow:

$$\lambda_w = \frac{C^2}{2g}h \quad (5.35)$$

This should be a multiple of the grid spacing Δx . If k is the wave number of bed oscillations, the non-dimensional number $k \cdot \lambda_w$ is a measure of the relative importance of flow momentum compared to bed friction. For small values, bed friction will be important where (for instance) flow over a shallow bar is reduced by bed friction, which causes bar growth. For higher values, flow deflection will be less as flow momentum is more important. Consequently, bed disturbances tend to be smoothed.

See Adaption Lengths (p. 55) for more information.

5.30 Structures

5.30.1 Location of a structure

The location of a structure is given by a number of geo-referenced points which together make up a poly-line. The poly-line defines the width of the structure perpendicular to the flow direction e.g. for a weir it will describe the location of the crest in the horizontal plan view. For a culvert the poly-line should be given as a line perpendicular to the flow direction and further the line should intersect the mid point of the culvert.

A cell face is affected if the defining poly-line intersects the line segment connecting the mid points of the two adjacent grid cells. The flow through the structure is evenly distributed along the affected cell faces.



Note: MIKE 21C will interpret the (x,y) grid coordinates in the grid-file (generated from MIKE 21C Grid Generator) as projection coordinates with respect to the map projection provided in the bathymetry-file.

This means that the most straight forward way to manage the location of



structures relative to the (x,y) grid is to utilise the same map projection as in the bathymetry file such that the geo-referenced points spanning the structure and the (x,y) grid coordinates will be according to the same coordinate system.

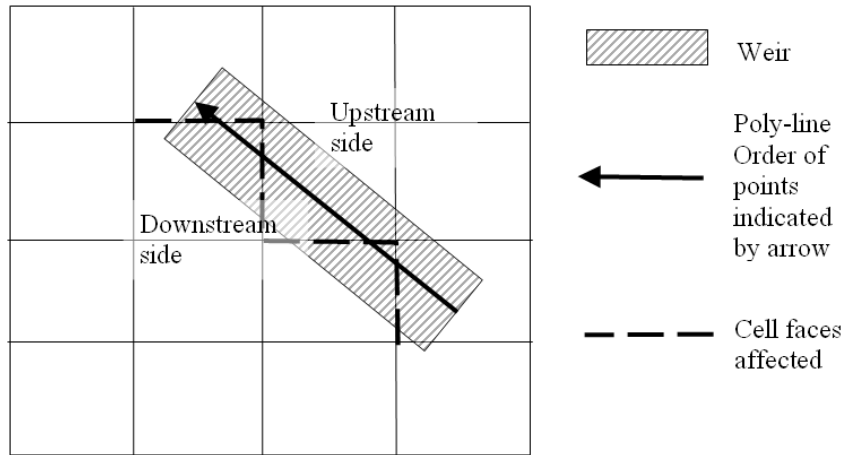

Figure 5.12 The location of a weir. Note the affected cell faces

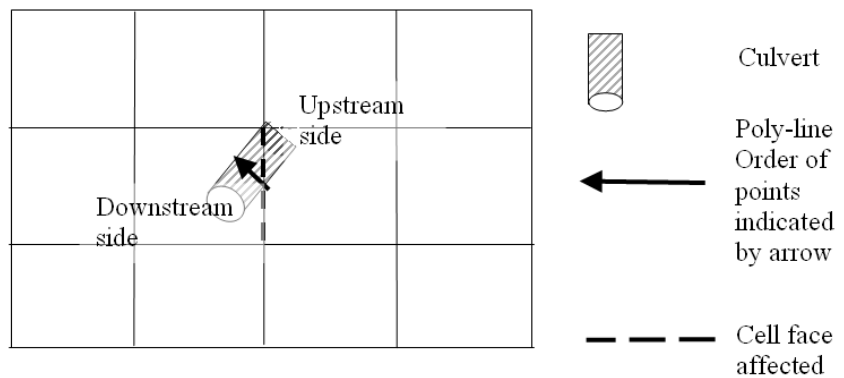

Figure 5.13 The location of a culvert. Note the affected cell face

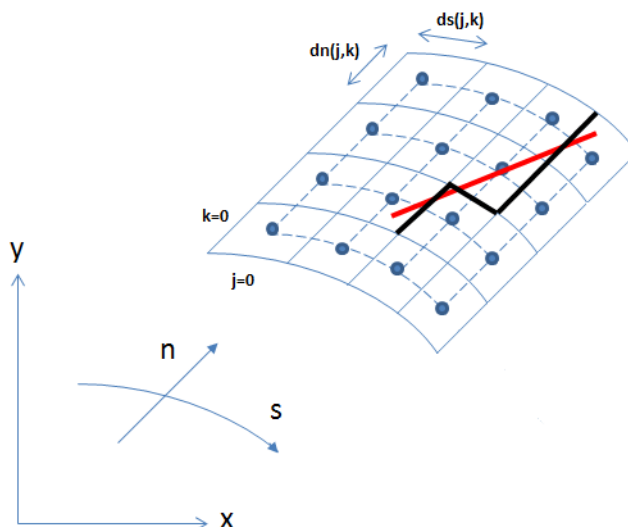

Figure 5.14 The location of a dike. Note the affected cell faces

5.30.2 Weirs

There are three types of weirs available

- Broad crested weir
- Weir formula 1
- Weir formula 2

The geometry of each of these is to be supplied by the user according to the sections below.

Broad crested weir

For a broad crested weir the user describes the shape of the “hole” through a level/width table (see Figure 5.15). The datum value for the structure may be used to shift the levels by a constant amount. The latter is typically used if the weir geometry has been surveyed with respect to a local benchmark.

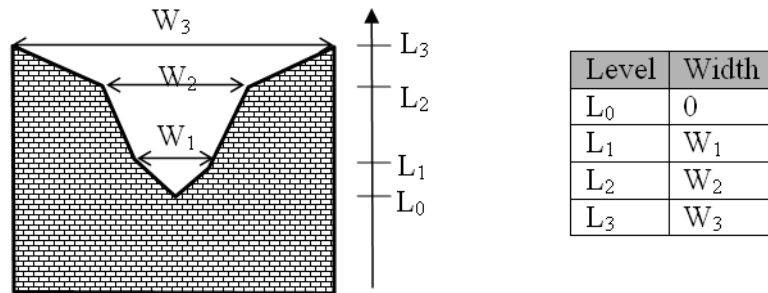

Figure 5.15 Definition sketch of broad crested weir geometry

The standard formulations for flow over a broad crested weir are established automatically by the program on the basis of the weir geometry and the user specified head loss and calibration coefficients. These formulations assume a hydrostatic pressure distribution on the weir crests. Different algorithms are used for drowned flow and free overflow, with an automatic switching between the two.

Weir formula 1

For the weir formula 1 description the parameters are given by Figure 5.16. The width is perpendicular to the flow direction. Typically the invert level coincides with the overall datum.

Weir formula 1 is based on a standard weir expression, reduced according to the Villemonte formula:

$$Q = WC(H_{us} - H_w)^k \left[1 - \left(\frac{H_{ds} - H_w}{H_{us} - H_w} \right)^{0,385} \right] \quad (5.36)$$

where Q is discharge through the structure, W is width, C is weir coefficient, k is the weir exponential coefficient, H_{us} is upstream water level, H_{ds} is downstream water level and H_w is weir level (see Figure 5.16).

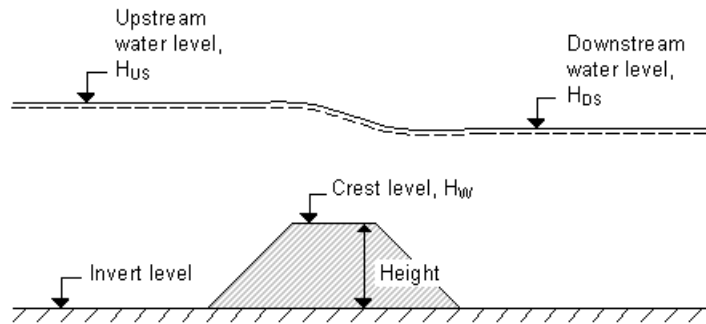

Figure 5.16 Definition sketch for weir flow

Weir formula 2

For the weir formula 2 the geometry is given by a crest level and a width. The crest level is taken with respect to the global datum. The width is perpendicular to the flow direction.

Weir formula 2 is the Honma formula:

$$Q = \begin{cases} C_1 W (H_{us} - H_w) \sqrt{(H_{us} - H_w)} & \text{for } (H_{ds} - H_w) / H_{us} < 2/3 \\ C_2 W (H_{ds} - H_w) \sqrt{(H_{us} - H_{ds})} & \text{for } (H_{ds} - H_w) / H_{us} \geq 2/3 \end{cases} \quad (5.37)$$

where Q is the discharge through structure, W is the width, C_1 is the weir coefficient 1, and C_2 , the weir coefficient 2, is calculated according to $C_2 = 1,5\sqrt{3} C_1$, H_{us} is the upstream water level, H_{ds} is the downstream water level and H_w is weir level (see Figure 5.16).

Head loss factors

The flow description generally used for a structure is given by:

$$\Delta H = \zeta_t \frac{V_s^2}{2g} \quad (5.38)$$

where ΔH is the energy loss over the structure, ζ_t is the total head loss coefficient and V_s is the mean cross sectional velocity at the structure.



The total head loss coefficient (ζ_t) is composed of entrance (ζ_1) and exit (ζ_2) coefficients. The coefficients are generally related to the input parameters for Inflow (ζ_{in}) and Outflow (ζ_{out}) and the changes in velocity (v) and area (A):

$$\zeta_t = \zeta_1 + \zeta_2 = \zeta_{in} \left(\frac{V_1}{V_s} \right) + \zeta_{out} \left(\frac{A_s}{A_2} \right)^2 \quad (5.39)$$

where suffix '1' and '2' represents velocity and Area on inflow and outflow side of structure respectively, and 's' represents the velocity and Area in the structure itself.

For subcritical flow through a structure there is an upstream contraction and a downstream expansion, so the above equation works fine.

However, in the present implementation, upstream and downstream cross sections are not extracted and accordingly, tabulated relations on cross section areas as function of water levels are not known. Instead, upstream and downstream areas are set to a large number resulting in a full loss contribution from the head loss factors defined, namely:

$$\zeta_t = \zeta_1 + \zeta_2 = \zeta_{in} + \zeta_{out} \quad (5.40)$$

Care must be taken when selecting loss coefficients, particularly in situations where both subcritical and supercritical flow conditions occur. When flow conditions change from subcritical to supercritical (or the Froude number FR becomes greater than 1), the loss coefficients ζ_{in} and ζ_{out} (specified in the Head Loss Factors box) are modified:

- If $FR > 1$ in upstream h-point then $\zeta_{in} = \zeta_{in} / 2$
- If $FR > 1$ in downstream h-point then $\zeta_{out} = \zeta_{out} / 2$

Free overflow head loss factor

The critical flows (and orifice flows for culverts as well) are multiplied by the critical flow correction factor, α_c , specified as the Free Overflow Head Loss Factor. Typically a value of 1.0 is used.

5.30.3 Culverts

A culvert may be of three different geometries:

- Rectangular
- Circular
- Irregular (A level-width table)

Geometry

With the rectangular and the circular type geometries the width/height or the diameter is supplied.

For the Irregular type geometry the geometry is to be defined through a level-width relationship table, see Figure 5.17. Further the user must supply the invert levels of the culvert on the upstream and on the downstream side. The invert is the lowest point in the inlet/outlet section. Note that the values in the level width table are taken with respect to the inverts. Further the user must supply the length of the culvert (in the flow direction) and the resistance in the culvert. The latter is defined through the use of Manning's n ($=1/M$).

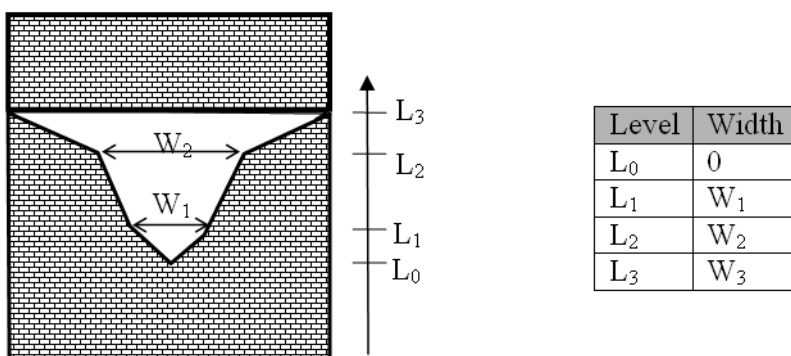

Figure 5.17 Definition sketch of irregular level-width culvert geometry

Closed / Open section switch

A culvert structure can be modelled as an open section if required by setting the Closed / Open switch. An example where this may be used is a “long” weir where the friction along the length of the weir is of importance and/or the flow areas at the entrance and exit are significantly different.

If set to open the culvert will never run full or partially full, therefore only those flow conditions which represent a free water surface are modelled. When the water level is higher than the soffit the hydraulic parameters are calculated based on a section extended vertically upwards with a width equal to that at the soffit. For example, in the case of a rectangular section the height value is essentially redundant as the cross-section will be modelled as an open section of constant width.

In the case of a circular section, this switch is invalid and will be set to closed.



Head loss factors

The total head loss, DH through a culvert is given by:

$$\Delta H_{loss} = \frac{Q^2}{2g} \left(\frac{\zeta_1}{A_{s_1}^2} + \frac{\zeta_f + \zeta_b}{A_{s_a}^2} + \frac{\zeta_2}{A_{s_2}^2} \right) \quad (5.41)$$

where A_s is the mean cross section area along the length of the culvert and Q is the discharge, ζ_1 is the entrance or contraction loss, ζ_2 is the outlet or expansion loss, ζ_f is the Friction loss calculated using the Manning formula and ζ_b is the bend loss coefficient.

$$\zeta_1 = \zeta_{in} \left(1 - \frac{A_{s_1}}{A_1} \right) \quad (5.42)$$

$$\zeta_2 = \zeta_{out} \left(1 - \frac{A_{s_2}}{A_2} \right)^2 \quad (5.43)$$

$$\zeta_f = \frac{2gLn^2}{R^{4/3}} \quad (5.44)$$

where L is the culvert length, n is Manning's coefficient and R is the mean Hydraulic Radius along the culvert. The Manning's n -value depends on the interior surface of the culvert. Table values can be found in literature. For e.g. a concrete culvert n would typically range from 0.011 to 0.017 .

The bend loss coefficient, ζ_b , is provided for situations where head losses other than from the above occur, for example bends, damaged culverts, trapped debris. For straight culverts in good condition a value of zero would apply.

Free overflow head loss factor

The critical flows (and orifice flows for culverts as well) are multiplied by the critical flow correction factor, α_c , specified as the Free Overflow Head Loss Factor. Typically a value of 1.0 is used.

5.30.4 Dikes

The flow, Q , over a section of the dike corresponding to an element face with the length (width), w , is based on a standard weir expression, reduced according to the Villemonthe formula:

$$\begin{aligned}
 Q &= wC(H_{us} - H_w)^{3/2} \left(1 - \left(\frac{H_{ds} - H_w}{H_{us} - H_w} \right)^{3/2} \right)^{0,385} && \text{for } H_{us} > H_{ds} > H_w \\
 Q &= wC(H_{us} - H_w)^{3/2} && \text{for } H_{us} > H_w \geq H_{ds} \\
 Q &= 0 && \text{for } H_w \geq H_{us} > H_{ds}
 \end{aligned}
 \tag{5.45}$$

where Q is discharge through the structure, w is the local width (cell face width), C is discharge coefficient, H_{us} is upstream water level, H_{ds} is downstream water level and H_w is the crest level taken with respect to the global datum (see Figure 5.18). The default value of the weir coefficient is 1.838.

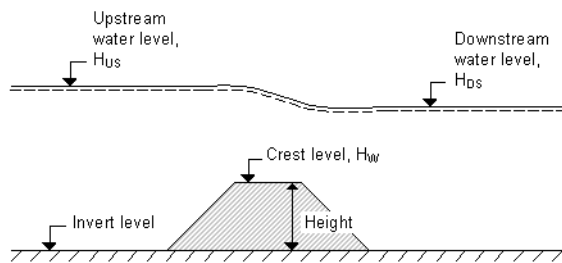

Figure 5.18 Definition sketch for Dike Flow

The geometry of a dike is defined as shown in Figure 5.19.

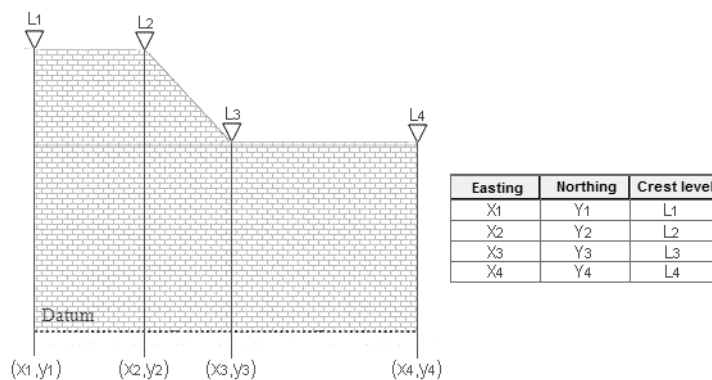

Figure 5.19 Definition sketch of spatial varying dike geometry



5.30.5 Flow directions for specific structure parameters

Positive and Negative flow directions as referred to in Valve and Head loss coefficient definitions follows the definition as presented in Figure 5.20. That is, positive flow direction is defined as the left perpendicular to the direction of a structure line schematisation.

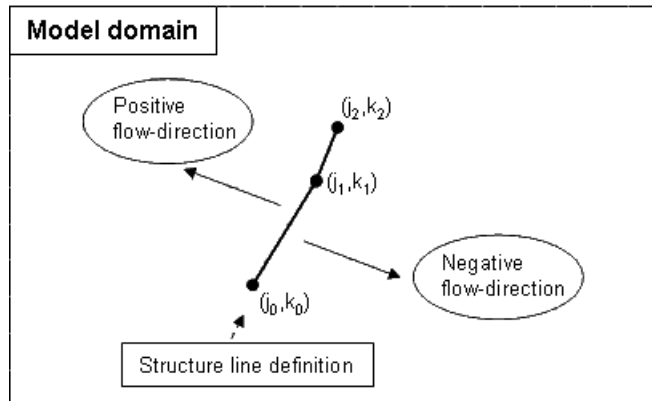

Figure 5.20 Positive and Negative flow direction definition at structures

5.30.6 Remarks and hints

To ensure that a structure is mapped properly onto one or more cell faces the defining poly-line should intersect the line segments connecting the cell centres. If the latter is not the case a warning is issued in the simulation-log and the structure is mapped onto the nearest cell face with a similar alignment as the defining line segment. To ensure a proper mapping simply extend the poly-line defining the structure location so that it intersects a line segment connecting cell mid-points, see Figure 5.21.

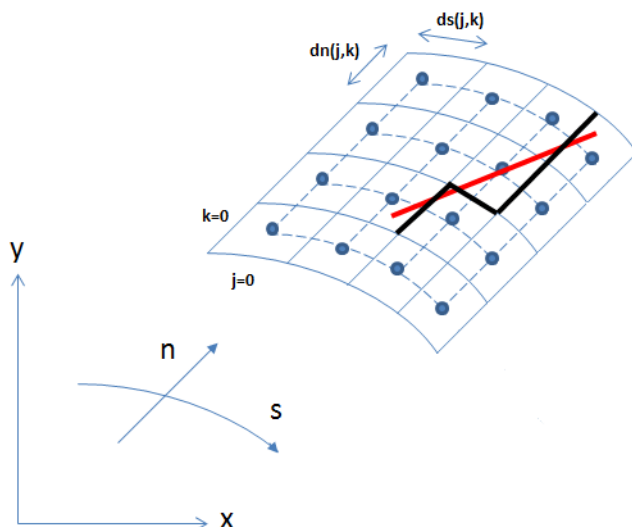

Figure 5.21 Definition of cell mid-points and affected cell faces

The affected cell faces are written to the simulation log for inspection. The format being:

```
n j k Top Posi
```

where **n** is an index of the number of cells affected, **j** and **k** refers to the individual cells. The value of **Top** is either 0 or 1 depending on whether the cell face is to the right or at the top of the cell. Finally the **Posi** value indicates whether the cell is the upstream (1) or the downstream side of the structure. Please note that the upstream and downstream definition is only of importance if the loss factors are asymmetric across the structure or the invert levels are different upstream and downstream.

5.31 Suspended Load

Suspended sediment transport is more complicated than bed load transport due to its three-dimensional character.

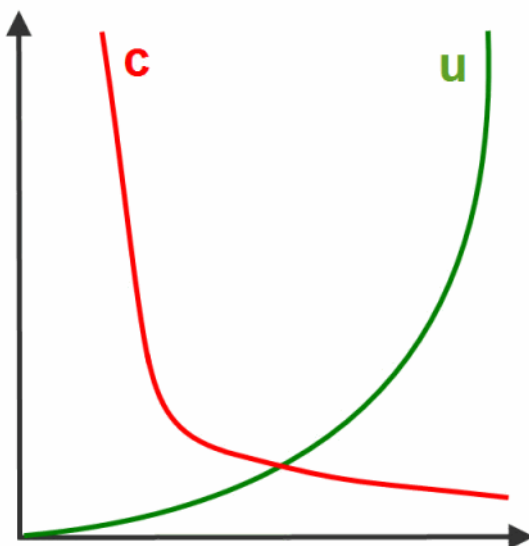

Figure 5.22 Three-dimensional character of Suspended sediment transport

To represent this three-dimensionality, the following features are included:

- retardation of suspended sediment transport (time and space lag)
- deflection of the mean sediment transport direction due to helical flow

The suspended load sediment model uses an advection-dispersion scheme, with erosion and deposition included as sources and sinks. The source and sink terms are found by comparing sediment transport **capacity** and **actual** sediment transport. The sediment transport capacity is computed using a selection of *Sediment Formulae*, including Engelund-Hansen (total load), van Rijn, Engelund-Fredsoe and Yang, and user-specified sediment formulas.

Furthermore, the mathematical formulation (asymptotic approximation theory) developed by Galappatti (1983) has been utilised (see *Profile Functions*). Through this formulation, the vertical velocity profile (main flow as well as secondary flow) and the vertical concentration profile are incorporated in the model (quasi-3D).

A relevant time scale for the time lag T is the settling time for a sediment grain at the water surface, $T = h/w_s$, where h is water depth and w_s is sediment fall velocity. The corresponding length scale is $L = T \cdot u$, where u is flow velocity. For example, if $h = 8$ m, $w_s = 0.02$ m/s and $u = 2$ m/s, the time and length scales are 400 s and 800 m, respectively. For this example, this means that the space lag is important.

The suspended sediment model can be switched off in the model input so that only a bed load model is applied. Analysis of sediment data and grain



sizes should assist in determining if suspended sediment transport constitutes an essential part of the total sediment transport.

5.32 Time-Step Selection

5.32.1 General

The model operates with different time-steps:

- the marching time-step Δt
- the hydrodynamic time-step Δt_{HD}
- the advection-dispersion time-step Δt_{AD}
- the sediment transport time-step Δt_{ST}

The hydrodynamic time-step is usually equal the marching time-step and is specified in the hydrodynamic input specification or the hot data file. How to select the time-step is described in the hydrodynamic users-manual. The hydrodynamic time-step can be specified explicitly in the *Options* file using the time-step dt_hd , in which case a quasi-steady model is assumed with $dt_hd < \Delta t$.

Simulations with helical flow and suspended load use an advection-dispersion scheme. For selection of the advection-dispersion time-step, the wave celerity Courant number C_r can be larger than 1, as described in the hydrodynamic manual:

$$C_r = \frac{c \cdot \Delta t}{\min(\Delta x, \Delta y)} \quad (5.46)$$

where c is the wave celerity. On the other hand, the transport Courant number $C_{r,tr}$ must be less than 1:

$$\Delta t_{max} = \frac{C_{r,tr}}{\frac{U}{\Delta x} + \frac{V}{\Delta y}} \quad (5.47)$$

where (U, V) is the flow velocity vector. In most situations a smaller time-step is required when running both hydrodynamics and advection-dispersion compared to only running hydrodynamics. The most common reason for model instability is the time-step being too long.

The sediment transport time-step is usually much larger than the hydrodynamic and advection-dispersion time-steps. The Courant criterion governing its value is still the same, except the wave celerity in this case is the celerity



of bed form waves. As the sediment continuity equation is solved using an explicit scheme, the Courant number must be less than 1:

$$\Delta t_{ST, max} = \Delta x \cdot \frac{C_{r, ST}}{c_{ST}} \quad (5.48)$$

The sediment transport time-step is defined by specifying a multiple n_{sthd} of the hydrodynamic time-step. Also, a scale factor sf can be specified to simulate artificially 'time-compressed' events.

$$\Delta t_{ST} = n \cdot \Delta t \cdot sf \quad (5.49)$$

5.32.2 Quasi-steady approach

When n_{sthd} is greater than 1 or if $Dt_{AD} < Dt$, the advection-dispersion model used for computation of suspended sediment transport and helical flow calculates a stationary concentration field. This means a quasi-steady approach is employed, which is necessary when using a scale factor. The advection-dispersion model iterates until the time derivative of the concentration vanishes.

The maximum number of iterations is default 21, although this can be specified in the input. If the AD time-step is too small, there may not be enough iterations to achieve steady conditions in the concentration field. This can be detected in the log file containing simulation information, by comparing the number of iterations performed with the maximum number permitted. If the maximum number permitted is reached every time-step, more iterations may be necessary. On the other hand, if the AD time-step is too big, local instability may occur, and the maximum permitted iterations may also be reached. Optimisation is therefore required.

5.32.3 Hints

The variables Dt , Dt_{HD} , n_{sthd} , Dt_{AD} and sf should be chosen so that reasonable Courant numbers for each of the HD, AD and ST models are obtained. Typical values of each are:

- values of n_{sthd} between 5 and 30
- the scale factor sf is usually in the range 5 to 50 of $Dt = Dt_{HD}$
- for $sf = 1$, Dt may be around 5-50 times the Dt_{HD}

It is not uncommon that the advection-dispersion model reaches the maximum permitted number of iterations during the sediment transport simulation. This is acceptable if it does not occur at every sediment transport step and if the deviation between the last two iteration steps is not significant.



5.33 Update Computational Grid

The option is available to continuously update the curvilinear grid during model simulation in accordance with simulated bank erosion. This is important especially for long-term simulations of river bends. When a certain accumulated bank erosion at a certain location is exceeded, the model activates a grid generator (similar to **m21gg**), and updates the curvilinear grid and bathymetry maps. This means that the grid generator is not necessarily activated at every sediment transport time-step but only when there is a need for grid updating.

Similar model parameters to those for the standard grid generator (m21gg) are required, except that boundary lines are taken directly from the morphological model (but updated with accumulated bank erosion). The model parameters are:

- **Land points**
Grid points that are land points are specified (i.e. where bank erosion is attacking). Four values are required for the number of land points defined along each boundary in a clockwise direction; North, East, South and West. For example, if a model has an upstream west flow boundary, a downstream east water level boundary, a row of grid points defining the north land boundary and two rows defining the south land boundary, the entries would be 1 0 2 0. Presently, only eroding banks along north and south bank is possible with the model.
- **Courant criterion for update**
When the accumulated bank erosion at any point on the eroding banks is more than this value multiplied by the local transverse grid spacing (Dx), grid generation is initiated. If initiated, the accumulated bank erosion is reset.
- **Stop criterion**
Grid generation is an iterative process. When the maximum relative difference between the two last iteration steps is less than this parameter, grid generation is complete. The number of iterations depends on the maximum allowed bank move Courant number? The smaller Courant criterion, the fewer iteration steps are required.
- **Maximum number of iterations**
Grid generation is an iterative process. When the maximum relative difference between the two last iteration steps never reaches the Stop Criterion, the iterative procedure will stop after this maximum specified number. The number of iterations depends on the maximum allowed bank move Courant number? The smaller Courant criterion, the fewer iteration steps are required.



- **Sweeps on bank line changes**

The simulated bank line changes (bank erosion) are smoothed along the boundary before being introduced as new boundary line coordinates. This parameter defines how many times the smoothing sweep,

$$\Delta_{j,k} = (\Delta_{j-1,k} + \Delta_{j,k} + \Delta_{j+1,k})/3$$

is performed.

- **Sweeps on grid weight**

Grid weights are calculated from the previous grid and subsequently smoothed:

$$q_{j,k} = (q_{j-1,k} + q_{j,k} + q_{j,k-1} + q_{j,k+1} + q_{j+1,k})/5.$$

This parameter determines how many times this smoothing sweep is performed.

- **Move bathymetry opposite grid**

When grid points are updated (moved), all state variable such as bed level, depth, surface elevation, flux in each direction, Chezy number, etc should ideally be updated, as these variables are valid in fixed physical points rather than numerical points. From the perspective of the model domain, these state variables should be shifted in the opposite direction to the movement of the curvilinear grid. As the model is usually operating in a quasi-steady manner when the grid is updated, it is sufficient to only update bed levels (the bathymetry). This is done with a non-dissipative advection scheme.

- **Freeze internal true land**

During grid generation true land points can be specified inside the model area. This will fix the locations of these points during the grid generation update. Note that this option may violate the orthogonality criterion if the grid changes significantly. Thus, the parameter should be used with care.

- **Stone parameter**

See Scientific Documentation for m21gg.

- **Boundary relaxation**

See Scientific Documentation for m21gg.

- **Maximum curvature of bank line**

See Scientific Documentation for m21gg.

- **Maximum curvature of grid weights**

See Scientific Documentation for m21gg.



- **Output of the grid generator**
Besides providing new coordinates, grid spacing, grid line curvatures etc. for the morphological model, the grid generator also produces a separate grid file (2D) containing the x and y coordinates. This file is required by the model.

5.34 References

- Bendegom, L. van (1947), "Some considerations on River Morphology and River Improvement", *De Ingenieur*, 59, No. 4, p. B1-11.
- Booij, R. and Kalkwijk, J.P.T. (1982), "Secondary Flow in estuaries due to the curvature of the main flow and to the rotation of the earth and its development", Report 9-82, Lab. Of Fluid Mech., Dep. Of Civil Eng., Delft Univ. of tech, Delft.
- Engelund, F. (1974), "Flow and bed topography in channel bends", *J.Hyd.Div, ASCE*, Vol.100, No. HY11.
- Engelund, F. and Hansen, E. 1967, "A monograph on sediment transport in alluvial streams", Teknisk Forlag, Danish Technological University, Copenhagen, Denmark.
- Engelund, F. and Fredsøe, J. (1976), "A sediment transport model for straight alluvial channels", *Nordic Hydrology*, Vol. 7, No. 5.
- Engelund, F. and Fredsøe, J. (1982), "Hydraulic theory of alluvial rivers", *Advances in Hydro Science*, Vol. 13, pp. 187-215.
- Fredsøe, J. (1978), "Sedimentation of River navigation channels", *J. Hyd. Div., ASCE, Hy2*, February, pp.223-236.
- Fredsøe, J. (1978), "Meandering and Braiding of rivers", *J. Fluid Mech. Vol. 84*, Part 4.
- Fredsøe, J., 1979, "Unsteady flow in straight alluvial streams: Modifications of individual dunes", *J. Fluid.Mech*, Vol.91, pp 497-512.
- Galappatti, R., 1983, "A depth-integrated model for suspended transport", Report No. 83-7, comm. On hydraulics, Dept. of Civil Engineering, Delft Univ. of Technology.
- Galappatti, R. and Vreugdenhill, C.B., 1985, "A depth-integrated model for suspended transport", *Jour. Of Hyd. Research*, Vol. 23, No. 4.
- Hickin, E.J, Nanson, G.C. (1984), "Lateral migration rates of river bends", *J. Hyd. Eng., ASCE*, Vol. 110, No.11.
- Hungr, O. (1995). A model for the runout analysis of rapid flow slides, debris flows, and avalanches. *Canadian Geotechnical Journal*, 32(4), 610-623.



- Ikeda, S. (1980), "Incipient motion of sand particles on slopes", Rep. Of Found. Eng. & Constr. Eng., Saitama Univ., Japan.
- Jansen, P.H., van Bendegom, L., van den Berg, J., de Vries, M., and Zanen, A. (1979), "Principles of River Engineering", Pitman Publishing.
- Jeyapalan, J. K., Duncan, J. M., & Seed, H. B. (1983). Investigation of flow failures of tailings dams. *Journal of geotechnical engineering*, 109(2), 172-189.
- Julien, P.Y. (2010) *Erosion and Sedimentation, Second Edition*. Cambridge University Press. 2010.
- Kalkwijk, J. P. T., and Booij, R. (1986), "Adaptation of secondary flow to nearly horizontal flow", *J. Hyd. Res*, 24, no1. P18.
- Kalkwijk, J. P. Th, and de Vriend, H. J. (1980), "Computation of the flow in shallow river bends", *J. Hyd. Res.*, 18, No.4, p327.
- Kikkawa, H., Ikeda, J., and Kitagawa, A. 1976, "Flow and bed topography in curved open channels", *J. Hyd. Div., ASCE*, Vol.102, No. HY9.
- Klaassen, G. J, Mosselman, E., Masselink, G., Brühl, H., Huisink, M., Koomen, E., Seymonsbergen, A.C. (1993), "Planform changes in large braided sand-bed rivers", *Delft Hydraulics*, Publ. No. 480, Dec. 1993.
- Klaassen, G. J, Masselink, G. (1992), "Planform changes of a braided river with fine sand as bed and bank material, 5. *Int. Symposium on River Sedimentation*, April 1992, Karlsruhe, Germany.
- Koch, F.G. (1980), "Bed level computation for axis-symmetric curved channels", Rep. R567-1X/W308 part1, Delft Hyd. Lab.
- Lane, E.W. (1953), "Progress report on studies on the design of stable channels by the Bureau of Reclamation", *Proc. ASCE, Irr. And Drain, Div.*, Vol. 79.
- Majumdar, S., Rodi, W., Zhu, J. (1992) "Three-dimensional finite-volume method for incompressible flows with complex boundaries", *Journal of Fluids Engineering*, Vol. 114, pp 496-503.
- Meyer-Peter, E. and Müller, R. (1948), "Formulas for bed load transport", *Proc. 2nd Congr. IAHR, Stokholm*, Vol.2, paper 2.
- Michelsen, J.A. (1989) "Solution of the Navier-Stokes equations on general non-orthogonal meshes", FTU/STVF pr J.nr. 95 83 02, Department of Fluid Mechanics, Technical University of Denmark, pp 1-45.
- Mosselman, E. (1992), "Mathematical modelling of morphological processes in rivers with erodible cohesive banks", *Comm. on Hydr. and Geotec. Eng.*, No.92-3, Delft University of Technology.



- Naef, D., Rickenmann, D., Rutschmann, P., & McArdell, B. W. (2006). Comparison of flow resistance relations for debris flows using a one-dimensional finite element simulation model. *Natural Hazards and Earth System Science*, 6(1), 155-165.
- Nouh, M.A. and Townsend, R.D. (1979), "Shear stress distribution in stable channel bends", *Proc. ASCE, J. Hyd. Div.*, 105, HY10.
- Odgaard, A.J. (1981), "Transverse bed slope in alluvial channel bends", *J. Hyd. Div, ASCE, Vol.107, No. HY12*.
- Olesen, K.W. (1987), "Bed topography in shallow river bends", *Faculty of Civil. Eng., Delft Univ. of Tech, Report 87-1*.
- Parker, G. (1983), "Theory of meander bend deformation", *Proc. ASCE Conf. Rivers '83, New Orleans*.
- Pastor, M., Quecedo, M., González, E., Herreros, M. I., Merodo, J. F., & Mira, P. (2004). Simple approximation to bottom friction for Bingham fluid depth integrated models. *Journal of Hydraulic Engineering*, 130(2), 149-155.
- Patankar, S.V. (1980) "Numerical Heat Transfer and Fluid Flow", McGraw-Hill.
- Rijn, L. C. van , 1984, "Part I: Bed load transport", *J. Hyd. Eng.*, 110, October, "Part II: Suspended load transport", *J. Hyd. Eng.*, 110, November.
- Rozowskii, I.L. (1957), "Flow of water in bends of open channels", *English translation: Israel Progr. For Scientific Transl. Jerusalem, 1961*.
- Smart, G. M. and Jaeggi, M. N. R. (1983) "Sediment Transport on Steep Slopes", *Mitteilung nr. 64 of the Laboratory for Hydraulics, Hydrology, and Glaciology at the Federal Technical University, Zürich*.
- Stone, H.L. (1968) "Iterative solution of implicit approximations of multidimensional partial differential equations", *SIAM Journal Num. Analysis*, Vol. 5, No 3, pp 530-559.
- Struiksmá, N., Olesen, K.W., Flokstra, C., and de Vriend, H.J. (1985), "Bed deformation in curved alluvial channels", *J. of Hyd. Res.*, Vol. 23, No.1.
- Talmon, A.M., 1992, "Bed topography of river bends with suspended sediment transport", *Ph.D. Thesis, Delft Univ. of Tech*.
- Talmon, A.M., Struiksmá, N. and van Mierlo, M.C.L.M. (1995), "Laboratory measurements of the direction of sediment transport on transverse alluvial bed slopes", *J. Hyd. Res.*, Vol.33, No. 4, 1995.
- Vanoni, V.A. (1975), "Sedimentation Engineering", *ASCE manuals and reports on engineering practice, No. 54, New York*.



- Vanoni, V.A. (1984), "Fifty Years of Sedimentation", J. Hyd. Eng. ASCE, Vol. 110, No. 8.
- Vriend, H. J. de (1981), "Steady flow in shallow channel bends", comm. on Hydraulics 81-3, Dept. of Civil. Eng., Delft Univ. of Tech.
- Vriend, H. J. de and Struiksma, N. (1983), "Flow and bed deformation in river bends", Proc. ASCE Conference Rivers '83, New Orleans, p. 810.
- Yang, C. T. (1983) "Rate of Energy Dissipation and River Sedimentation", 2nd International Symposium on River Sedimentation, Nanjing, China, pp. 575-585.
- Yang, C. T. (1984) "Unit Stream Power Equation for Gravel", Journal of Hydraulic Division, ASCE, Vol. 120, No. 9, pp. 1021-1042.





6 Examples

6.1 Morphological Model of a Meandering Stream

6.1.1 Introduction

This tutorial describes the development of a morphological model of a meandering stream. The purpose is to demonstrate the capabilities of MIKE 21C. Important parameters and data files for the MIKE 21C model are described and discussed in the following step by step tutorial.

6.1.2 Before starting this tutorial

This is a tutorial and some of the files are pre-prepared. In particular, the curvilinear grid has already been generated. Furthermore, the MIKE 21C model uses the MIKE Zero model environment. It is assumed that you are familiar with this interface and are aware of the various file types used in MIKE Zero. In particular, references are often made to the **Result Viewer**, used to visualise model results.

This tutorial glosses over some of the more routine steps, which are required when creating a curvilinear model. If you have difficulty following this tutorial consider looking at the **U-Flume** tutorial first, which contains a more detailed description of the model development methodology.

Files to start with

There are only two files that you need for this tutorial - the rest will be created. The following files contain the bathymetry and grid coordinates:

- **meander_bathy.dfs2** - This file contains the bed levels at each grid cell for the first simulation
- **meander_grid.dfs2** - This file contains the curvilinear coordinates of the grid.

Use the **Result Viewer** to look at these files.

6.1.3 Problem definition

This is a simplified problem that highlights the processes occurring in a meandering stream. The bend curvature induces helical flow, leading to the formation of bend scour along the outer bend and a point bar along the inner bend. Development of the model is a stepwise procedure, starting simply and gradually adding more components. This is the recommended way of developing a model, as the effect of each individual step can be investigated. This will improve the understanding of the processes involved and will highlight

important parameters. Also, if any problems occur it should be easier to find the cause. Model development will follow the procedure:

- Define the problem
- Simulate hydrodynamic hot start conditions
- Simulate hydrodynamics and sediment transport
- Include river morphology in the simulation
- Investigate parameters that influence model predictions

Of particular interest in this example is the use of bank erosion in the simulation. An assessment is made of the effects of the helical flow and the distribution between bed load and suspended load on the morphological development.

6.1.4 Model bathymetry

The model is a meandering stream with a total stream length of 4000 m and width 50 m. There are eight meanders in the stream, as shown in Figure 6.1. The model is 498 grid cells in length and 12 grid cells in width (10 in the channel and 2 land cells). The bed level is 2 m at the upstream boundary and linearly drops down to 0 m at the downstream boundary (bed slope = 0.0005).

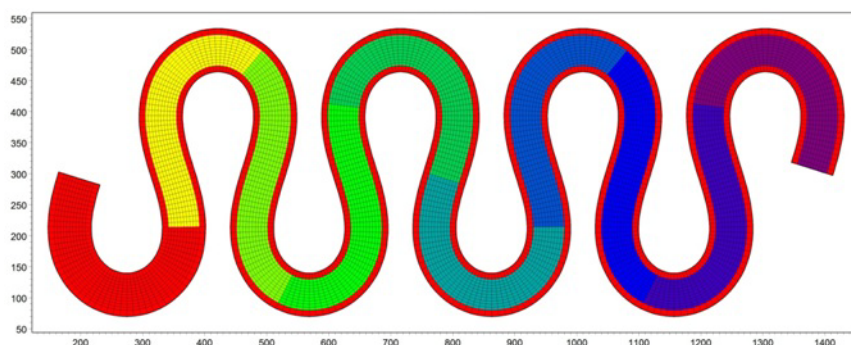

Figure 6.1 Bathymetry of meandering stream

6.1.5 Hydrodynamic simulation

Hot-start

The hydrodynamic simulation is a simple one. A constant upstream discharge of $35 \text{ m}^3/\text{s}$ is applied with a constant downstream water level of 1.0 m. This first simulation will be used as a hot start for the subsequent morphological simulation and also as a check to ensure that the hydrodynamic conditions are OK.



To start, create a new simulation file in MIKE Zero, using the menu commands “File -> New”. This will create the MIKE 21C definition file (extension .M21C). To define the model simulation, each sub-menu needs to be filled in with appropriate information. When this has been done, a green tick appears in the relevant box. If there is an error, a red cross is shown.

The basic parameters needed are as follows:

Module selection - hydrodynamics only

This is an HD simulation. Later simulations will also include river morphology.

Bathymetry - cold start

In this menu the model bathymetry needs to be defined, which includes the bathymetry file (meander_bathy.dfs2) and grid coordinate file (meander_grid.dfs2). This is a cold start simulation, meaning that the model will be 'warmed up' from an initial condition (only the initial water level can be specified for MIKE 21C), adjusting to the boundary conditions.

Simulation period

The simulation period is for 3600 time-steps at a time-step interval of 10 s (i.e. 10 hours). As this is a cold start, a warm up period of 600 time-steps is specified. During this period the boundary conditions will ramp up linearly from the initial condition to the specified boundary conditions (see Hydrodynamic Parameters below). The starting time of the hot start should be set so the simulation ends on 01 January 2000 at 00:00:00 hours (simulation start date: 31-12-1999 14:00:00).

Boundary

This menu defines the boundary conditions. In this case the boundaries have been defined during bathymetry generation, so can be simply set here as “Program detected”.

Source and sink

No sources or sinks are specified.

Flood and dry

Set the flooding and drying depths as 0.05 m drying depth and 0.10 m flooding depth. Note that these are stored in the hot start file written from the simulation, and therefore are inherited by any simulation using the hot start file.

The Hydrodynamic Parameters needed are as follows:

Initial surface elevation

The initial horizontal surface elevation is a constant value of 3.0 m.

Boundary

The Boundary Menu in the Basic Parameters defines the locations of the boundaries. This menu defines the type of conditions used at the boundaries.



This simulation uses a constant upstream discharge (or flux) of 35 m³/s and a constant downstream water level of 1.0 m.

The user should note that the use of warm up is particularly useful when the boundary conditions and initial conditions do not match; here the initial water level is 3.0 m while the downstream water level condition is 1.0 m. Warm up is still useful when the initial water level and water level boundary conditions are identical because the warm up also applies to the discharge, and the discharge is always zero as initial condition (cannot be prescribed in MIKE 21C in the same way as the initial water level). A constant initial water level of 2.0 m would not work for this model, as it would render the inflow boundary dry, and therefore the model would not function. Therefore an initial water level map (dfs2 file) would have to be prescribed to match the downstream water level boundary condition of 1.0 m and at the same time avoid an initially dry inflow boundary (where the bed level is 2.0 m). Warm up is an easier solution in this case, but for many cases, in particular very long models with a large water level gradient from upstream to downstream, where a constant water level is too far from reality to be used as initial condition. In such cases the initial water level must be specified as a map.

Source and sink

None.

Eddy viscosity

A uniform velocity based eddy viscosity is applied, with a constant of 1 m²/s. Velocity based eddy viscosity should always be selected for river applications with MIKE 21C. The flux based eddy viscosity is only acceptable in cases with little relative spatial variation in the water depth or very dominating high bed friction (i.e. deep water or floodplain).

Resistance

A uniform Manning's M bed resistance value of 35 m^{1/3}/s is applied.

HD integration

This simulation is Scaled Dynamic with an HD time-step of 2 sec (scale factor 5). The general time-step of 10 sec cannot be used for the hydrodynamic model, as it is too high for a stable solution. So while the simulation runs for 10 hours, the hydrodynamics actually only experiences two hours due to the scale factor of 5.

Results

A result file is specified. Name the file "hd_hotstart.dfs2". A title can optionally be included in the file definition. Set the output frequency of e.g. every 10 minutes. Also specify a hot start file called hotstart.dfs2. It is the hot-start file that matters for this run, but the HD result file is usually written as well in order to check that the simulation results are sound.

When all information required for a simulation has been defined, every box will contain a green tick. The validation window on the bottom of the dialogue



will also have a 0 error message. Save the MIKE 21C file as hotstart.M21C, then run the simulation using the Menu commands “Run -> Start simulation...”. The simulation dialogue will then appear.

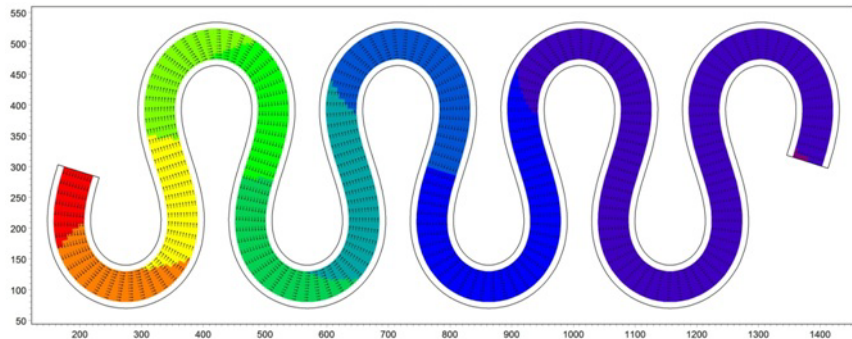

Figure 6.2 Simulated flow field at the end of the hot start run, note in particular the acceleration of the flow along the inner banks

Once the simulation has completed, check the results. Has the simulation stabilised from the initial warm-up? Is the simulation time long enough for the steady state hydrodynamic conditions to develop? Time series output at selected locations in the model domain is a useful way to check this (especially water levels). The depth and width averaged hydrodynamic conditions can be checked using the Chezy equation:

$$Q = CA\sqrt{R_h S} = Mh^{1/6}A\sqrt{R_h S} \quad (6.1)$$

where Q is flow discharge, M is Manning's number, A is area, R_h is hydraulic radius (essentially the water depth in this case) and S is bed slope. Check the water depth in the model and ensure that the calculated flow matches the boundary conditions in the model. Also check velocities, bearing in mind that there will be a cross-sectional variation around the meander bends (in particular the velocity is highest along the inner banks due to the shorter distance compared to the outer banks).

6.1.6 Morphological simulation

Helical flow

An HD simulation has now been successfully performed. The created hot start file will be used as initial conditions for the following morphological simulation. The next step is to include helical flow, which will be ultimately used in the morphological simulation.

Set the down stream boundary condition to 1 m.



Make a copy of the input file (hotstart.M21C) by using the Save as... function in MIKE Zero or simply by copying the input file in e.g. Windows Explorer. Call the new input file helical.M21C. Update the module selection to Hydrodynamics and river morphology. The menu "River Morphology Parameters" will now appear in the tree view. Change the simulation to hot-start from the hot-start file created in the first simulation, while keeping the boundary conditions, as the same boundary conditions would otherwise have to be specified again if recalculating. The menus highlighted below require specific information relating to this simulation:

Starting conditions

Until morphological processes are included this is a steady state problem (due to the constant hydrodynamic boundary conditions and non-varying bathymetry). Set the simulation period in the basic parameters to be 8640 time-steps (i.e. 24 hours) with a morphological frequency of 60 (i.e. 10 minutes). This automatically adjusts the period in the river morphology starting conditions also. Set the morphological drying depth to 0.05 m, which is also the hydrodynamic drying depth. Tick the box indicating that helical flow should be modelled, and nothing else. The AD solution is used as part of the helical flow calculations due to the adaptation in time and space of the helical flow intensity. Use the default values for the Implicit AD solver, which are maximum 10 iterations, relaxation factor 1.0 and a stop criterion of 10^{-6} . In the implicit AD model, the helical flow AD equation is integrated implicitly at every morphological time-step.

Helical flow

Helical flow intensity is defined as the deviation, $\tan \delta$, of the shear stress at the bed due to the secondary currents that occur around river bends. Set the constant value (δ , with a recommended range between 0.4 and 1.2) to 1, with the maximum value of $\tan \delta$ to 1. For more information on helical flow, check the reference manual.

Results

Specify an ST output file called st_helical.dfs2 along with an HD output file hd_helical.dfs2 (the HD solution is the same, as for the hot-start, but write it anyway for consistency; the HD solution will change when the morphology changes). If the constant value is set to 1 then helical flow intensity is approximately equal to $10h/R$, where h is depth and R is bend radius. For this application the meander radius varies from approximately 70 m (inner bend) to 130 m (outer bend), so with a water depth of 1 m helical flow intensity should be of the order of 0.14 (inner bend) to 0.07 (outer bend). Run the simulation and check the results to ensure that this is the case.

Sediment transport

Sediment transport is now included by updating the river morphology starting conditions. Set the morphological update frequency to 6, which means the morphological time-step will become 60 s. This time-step is lower than for the pure helical flow calculation, but now the sediment transport has been added,



and when the morphological calculation are added, the stability criterion for the sediment continuity equation (solved explicitly) needs to be included in the time-step selection.

Sediment parameters

Only one fraction is simulated. The sediment porosity, density and Critical Shields Parameter are 0.35, 2.65 and 0.056 respectively, which is typical for sandy material. Bed slope effects can become very important to the development of bed formations. For this simulation, set $G = 1.25$, $a = 0.5$ and $e = 5$ (default values for field conditions). The “Maximum concentration allowed due to erosion” parameter is important for stability, and the default value of $50,000 \text{ g/m}^3$ is sufficient for this application. The value of $50,000 \text{ g/m}^3$ may sound extremely high for sand, but the purpose is mostly to suppress bed level changes comparable to the water depth in small cells, and such can occur in models due to unrealistic shear stresses that might be predicted when the water depth is close to the drying depth. The factor on the fall velocity can be used to adjust the fall velocity of particles compared to the internally calculated fall velocity, which is set to 1.

A constant grain size of 0.15 mm is applied. The initial concentration for non-cohesive sediment is always set internally in the model to be identical to the equilibrium concentration, i.e. the suspended load is initially equal to what would be calculated from the selected suspended load formula. Dispersion calculated from profile theory is already included in the suspended load advection-dispersion equation, but additional dispersion can be added via the Dispersion dialogue. Additional dispersion of $0.1 \text{ m}^2/\text{s}$ is good for stability, but one should be careful not to add too much, as it can influence the behaviour of the points bar significantly. Set dispersion to 0 in both the x- and the y-direction.

The van Rijn formula is used for both bed load and suspended load as this formula has a special formulation for each. Usually calibration factors are 1 for both. However, for calibration purposes, other parameters are specified here (0.8 for bed load and 0.2 for suspended load). Zero bed level change is by default specified at the boundaries, however only actually enforced at inflow boundaries (in this case only the upstream boundary).

Specify a result file that will contain suspended concentration, bed load, suspended load and total load. The result file name should be `st_sediment.dfs2`. Also write a new HD result file, `hd_sediment.dfs2`.

The Shields parameter is defined as:

$$\theta = \frac{\tau}{\rho g (s-1) d_{50}} = \frac{u^2}{C^2 (s-1) d_{50}} \quad (6.2)$$

For the given conditions in this model (HD parameters mentioned previously and $d_{50} = 0.15 \text{ mm}$ and $s = 2.65$), the Shields parameter will be approximately



1.8. The critical Shields parameter is 0.056, so sediment transport is expected.

Bed level update

Once satisfied that the sediment transport simulation is performing satisfactorily, the morphological update can be included. Open the previous simulation (“meander_sediment.M21C”). The menu “River Morphology Parameters” menu requires the following updates for this simulation:

Boundary

Change boundary condition at the down stream boundary to 1 m.

Starting conditions

Include Morphological Update in this simulation. An additional menu item, Morphological Update, will appear in the tree view. 10 hours is short time compared to the morphological time-scale of the system, so increase the simulation time to 10 days in the Simulation Period dialogue in order for the bed to develop point bar and bend scour. The simulation will still run with a general time-step of 10 sec and an HD time-step of 2 sec. Set the maximum iterations to 20 and the relaxation factor 0.7.

Sediment transport

Set dispersion coefficients in both the x- and the y-direction to 0.1 m²/s.

Morphological update

Specify zero layers. This means that the bed is an infinitely deep source of sediment (alluvial) with characteristics specified in the previous menu. It also means that the Equilibrium Layer Thickness parameters are not used, as these parameters are only relevant for cases where the local sediment layer thickness can become finite (and here it is always infinite). The Morphological Update parameters are upper limits to reduce local instabilities. Set all three parameters to zero (meaning that they will be inactive), as they are not needed for this simulation, while obviously the UpdateBathymetry check box should be unticked.

Results

Include in the output file the items “Bed level” and “Bed level change”. Save ST and HD results daily instead, as the morphological behaviour is much slower than just hydrodynamics, helical flow and sediment transport.

Save the setup file (“morphological.M21C”) and run the simulation.

There are two interesting effects that are seen in this simulation. Firstly, the cross-channel effects around the meander tend to make the outside of the bend deeper and the inside of the bend shallower. Over time, this effect will increase the radius of curvature of the meander. Secondly, the erosion and accretion patterns are not symmetrical around the bend. There tends to be more material deposited and eroded downstream of the bend. Over time, this



effect will tend to migrate the meander in a downstream direction. This effect is demonstrated better in the simulation demonstrating the formation of a braided stream.

Bank erosion

The meander radius will gradually increase over time in this problem. The outer banks will erode, which will contribute to the sediment budget in the system. Add Bank Erosion into the simulation to include this effect. Bank erosion will be calculated and the eroded material will be added to the sediment continuity equation, but without actually accounting for the erosion, i.e. erosion occurs, but no bank movement.

Specify two eroding banks. These banks represent the lateral boundaries along the entire length of the model. The coordinates of the banks are (0,1)-(497,1) and (0,10)-(497,10). Bank erosion is calculated from the empirical formula developed for sandy rivers:

$$E_b = \alpha \frac{\partial z}{\partial t} + \beta \frac{S}{h} + \gamma \quad (6.3)$$

where E_b is erosion rate [m/s], z is local bed level [m], t is time [sec], S is near bank sediment transport [m^2/s], h is water depth [m], and α and β are input parameters (γ is normally set to zero for practical applications, and only included for test purposes). Bank erosion is also included in the sediment continuity equation via the additional source term, S , given by:

$$\Delta S = E_b(h_b - z) \quad (6.4)$$

where h_b is the bank level [m] and z the bed level along the eroding bank [m]. The source term ΔS is added to the right hand side of the sediment continuity equation, and obviously this should only be used when the bank material is the same as the riverbed material (i.e. sandy river with sandy banks). For a sandy river with cohesive banks the eroded material should not be included in the river sediment budget.



Note that the eroding bank needs to be in an active part of the model - specifying bank erosion on cells that are land will have no effect because there will be no change in bed level or sediment supply. In model terms an eroding bank in MIKE 21C must follow a line in the grid direction (j or k) and all the cells in the eroding bank must be adjacent to land cells.

Consider the quantities of sediment transport. Compare a simulation with and without bank erosion to see the contribution to sediment transport concentrations. What effect does bank erosion have upon the results?

A classic and very important effect is illustrated with this simple example: Protecting an eroding bank means deeper scour levels along the bank because



the eroded material brings up the bed level. Protecting the bank from erosion removes this supply of sediment, and the result is deeper scour, which needs to be accounted for when considering design.

Long term

The next step is to consider the long term state of the meandering system. As demonstrated, the meander tends to expand and move downstream. The simulations to date have shown that the model can simulate this, but a longer term simulation is required to see dramatic changes in the system.

The boundary conditions for this problem are constant. If only considering a hydrodynamic simulation then this is a steady state problem. But, as bed levels change, hydrodynamic conditions change. This will be a slowly varying state, but dynamic nonetheless. The fully dynamic simulations performed so far have adopted a time-step of 10 s. The long term simulation will be performed over a time scale of at least several weeks. This means that if a fully dynamic simulation was used a huge number of time-steps would be required.

Reopen the hydrodynamic hot start setup file, appropriately named “hotstart”. Under the Basic Parameters -> Simulation Period menu, change the HD time-step to be 450 s. Then under the Hydrodynamic Parameters -> HD Integration menu, select a Scaled Dynamic solution with a HD time-step of 10 s. This means that the HD engine will use a 10 s time-step then the results will be scaled by a factor of 45 before being applied in the sediment transport and morphological calculations. This permits much longer time-steps, however any hydrodynamic response in the system will behave as if the simulation is being run at a 10 s time-step.

Rename the output hot start file, save the setup file as “hotstart_It.M21C” and run the simulation.

Once the hot start file has been created, reopen the morphological setup file and change the input hot start file to be hotstart_It.dfs2. This will update the time-step (imported from the hot-start dfs2 file when hot starting) in the Simulation Period menu. Also, set the time-step range to be 5000 steps. As above, reset the HD Integration menu to be Scaled Dynamic with a HD time-step of 10 s. In the River Morphology Parameters -> Starting Conditions menu, set the sediment time-step frequency to be 2 (i.e. morphological time-step 900 sec). Rename the output file name, save the setup file as “st_meander_It.dfs2” and run the simulation.

The simulation may become unstable. Significant changes to the model bathymetry occur during this simulation. This can create unexpected problems during the simulation, particularly where wetting and drying occurs. Try reducing the hydrodynamic time-step and / or the morphological time-step.

Note that to change the morphological time-step (450 s at present) will require the hot start simulation to be re-run.

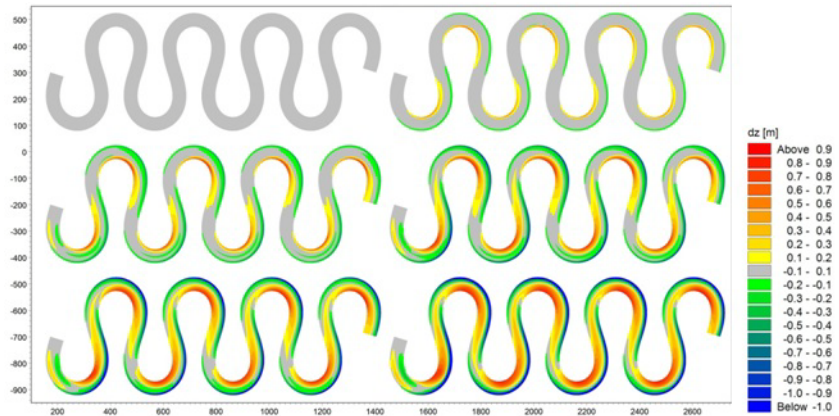

Figure 6.3 Simulated bed level changes after (a-f) 0, 125, 250, 375, 500 and 625 hours

Look at the results from the simulation. The following output is from an animation of bed level change over the simulation, with results after 0, 1000, 2000, 3000, 4000 and 5000 time-steps (0, 125, 250, 375, 500 and 625 hours).

Grid update

The next step is to consider the long term state of the meandering system. Repeat the simulation with the Grid Update facility activated. Check what effect this has upon the results.

6.1.7 Going further

The morphological model is complex. There are a number of parameters that can be modified within justifiable ranges that can produce significantly different results. If in doubt make sensitivity tests. Consider the following:

Bed slope effects

Sediment transport on transverse inclined bed slopes is an essential process to the development of bed topography of alluvial rivers. Sediment transport across the stream line is given as:

$$S_n = \left(\tan \delta - G\theta^{-a} \frac{\partial Z}{\partial n} \right) S_{bl} \quad (6.5)$$

where G (transverse slope coefficient) and a (transverse slope power) are the input parameters and is the helical flow strength (computed from the advection-dispersion model). Bed slope also influences the sediment transport in



the longitudinal direction. The sediment transport along the streamline is given as:

$$S_s = \left(1 - e \frac{\partial Z}{\partial S}\right) S_{bl} \quad (6.6)$$

where e is longitudinal slope coefficient (default $e=5$). It is noted that the e -value plays only a very small role, and is primarily used for stability purposes (it is easily shown that the e -term becomes a diffusion term when inserted into the sediment continuity equation). These G -value and a -value can vary, and different values have been recommended by various sources:

- Engelund-Fredsoe: $G = 0.625$, $a = 0.5$
- Kikkawa: $G = 0.6$
- Bendegom: $G = 0.667$, $a = 1$
- Struiksmas: $G = 0.588$, $a = 0.5$ or $G = 1.176$, $a = 0.5$

Laboratory tests made by Talmon (1992) suggest that G can differ significantly from one application to another. For high values of G , bed topography tends to stabilise itself. For small values of G , bed topography becomes more 'lively' or unstable, corresponding to a braided river. In summary, a higher G value means a less steep transverse bed slope. The value of a , has a similar effect but not as pronounced as G . Change $G = 3$ and $a = 1$, rerun the model and check the results. How does this affect the model predictions?

Change in bed load / suspended load

Modify the factors on the bed load and suspended load to 0.3 and 0.7 (previously 0.2 and 0.8); remember that these are not the ratios between bed load and suspended load when using a formula like van Rijn, in which bed load and suspended load are calculated from separate formulas. Rerun the simulation and check the results. The rate of development of bed level change should be less.

6.2 Morphological Model of a Trench

6.2.1 Introduction

This tutorial describes the development of a morphological model of a trench, positioned at a given angle to the flow direction. The purpose is to demonstrate the capabilities of MIKE 21C. Important parameters and data files for the MIKE 21C model are described and discussed in the following step by step tutorial.



6.2.2 Before starting this tutorial

This is a tutorial and some of the files are pre-prepared. In particular, the curvilinear grid has already been generated. If you want to learn about creating a curvilinear grid, see the M21GG tutorial. Further, the MIKE 21C model uses the MIKE Zero model environment. It is assumed that you are familiar with this interface and are aware of the various file types used in MIKE Zero. In particular, references are often made to the Result Viewer, used to visualise model results.

This tutorial glosses over some of the more routine steps. If you have difficulty following this tutorial consider looking at the U-Flume tutorial first, which provides more details of the model development methodology.

Files to start with

There are only three files that you need for this tutorial - the rest will be created. These files are the descriptions of bathymetry and the grid coordinates:

- `straight_bathy.dfs2` - This file contains the bed levels at each grid point for the first simulation (straight trench).
- `trench_grid.dfs2` - This file contains the curvilinear coordinates of the grid.

Use the Result Viewer to look at these files. The third file, `oblique_bathy.dfs2`, will be discussed later in this tutorial.

It is noted that there are two ways to define a rectilinear grid model in MIKE 21C. Here the grid is defined with a `dfs2` file (`trench_grid.dfs2`), but alternatively this grid file could be omitted completely if deactivating the Curvilinear grid checkbox under the Bathymetry dialogue, and at the same time ensuring that the `dx` and `dy` values in the bathymetry `dfs2` file are set to 5 m. This would give the same model, except that the grid direction would be west-east instead of south-north. When the Curvilinear grid checkbox is not activated, the grid properties (expressed internally in the code via the grid cell face lengths and curvature radii) are set directly from the bathymetry `dfs2` header (all cell faces are 5 m and there is no curvature).

6.2.3 Problem definition

This is a simplified example of a problem commonly seen in real applications. The trench acts as a sediment trap, where bed load and suspended sediment settles into the trench. In a more mobile sediment environment, the trench also migrates in the direction of flow.

Development of the model is a stepwise procedure, starting simply and gradually adding more components. This is the recommended way of developing a model, as the effect of each individual step can be seen. This helps under-



standing of the processes involved and will highlight important parameters. Also, if any problems occur it should be easier to isolate the cause. Model development will follow the procedure:

- Define the problem
- Simulate hydrodynamic conditions only
- Include sediment transport in the simulation
- Include river morphology in the simulation
- Investigate parameters that influence model predictions

Consider the following points when looking at this model development:

Grid size: how many cells are required to define the trench?

Grid size: grid size affects Courant numbers and time-steps. What implications does this have upon the simulation times?

HD Simulation: Are the HD simulation results OK? Are there any instabilities or unexpected results? Remember that any problems in the HD simulation will persist through into the morphological simulation.

ST Simulation: Are you getting as much sediment transport as you expected? How does the sediment transport rates compare to the bed shear stresses and the critical shear stresses? What transport formula are you using? Should sensitivity testing be considered to check the effect of other formulae?

RV Simulation: Are the morphological changes too rapid for the HD simulation? Should sensitivity testing be considered? Is the time-step appropriate for the given problem?

HD, ST and RV Simulations: Do you believe the results you are seeing? Can you interpret the model results to match the physical observations of the problem? Are the results different to what you expected, and if so, how do the results differ and why? This tutorial will address many of these considerations. Questions such as these should be kept in mind when developing any numerical model, but perhaps even more so with a morphological model because of the additional complexities.

6.2.4 Model bathymetry

The model is a uniform plane (500 m long and 300 m wide) with land along the lateral boundaries and a water depth of 2 m (bed level at -2 m). The downstream boundary is maintained at a constant water level of 0 m and an upstream flow condition is applied. Traversing the plane is a 50 m wide trench at a depth of 4 m (bed level at -4 m). In the initial model description (straight_bathy.dfs2) the trench is perpendicular to the flow direction, while in the second model (oblique_bathy.dfs2) the trench is aligned at 60° to the flow.



There are 60 grid points in the lateral (x) direction and 100 grid points in the longitudinal (y) direction. Grid size is 5 m (x) by 5 m (y). The curvilinear grid in this instance is uniform because there is no particular benefit in using a curved mesh. Having said this, for the second model of an oblique trench it could be argued that the mesh be aligned with the trench bathymetry. This would require additional mesh design. If this was a textbook this would be suggested as an additional exercise!

The model geometry for both models is shown in Figure 6.4 (straight channel on the left and oblique channel on the right).

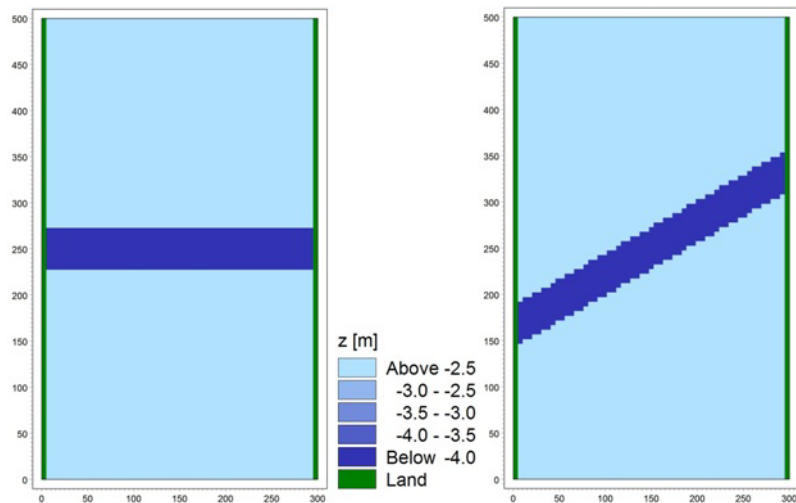

Figure 6.4 Model bathymetries, left: straight, right: oblique

The model geometry can be viewed in two ways. The first way is using the M21C Grid Generator (m21gg.exe) or in the Result Viewer within the MIKE Zero Interface. This is described in the MIKE 21C Grid Generator tutorial.

6.2.5 Hydrodynamic simulation - hot start

The hydrodynamic simulation is a simple one. A constant upstream discharge of 350 m³/s is applied with a constant downstream water level of 0.0 m. This first simulation will be used as a hot start for the subsequent morphological simulation and also as a check to ensure that the hydrodynamic conditions are OK. To start, create a new simulation file in MIKE Zero, using the menu commands "File -> New":

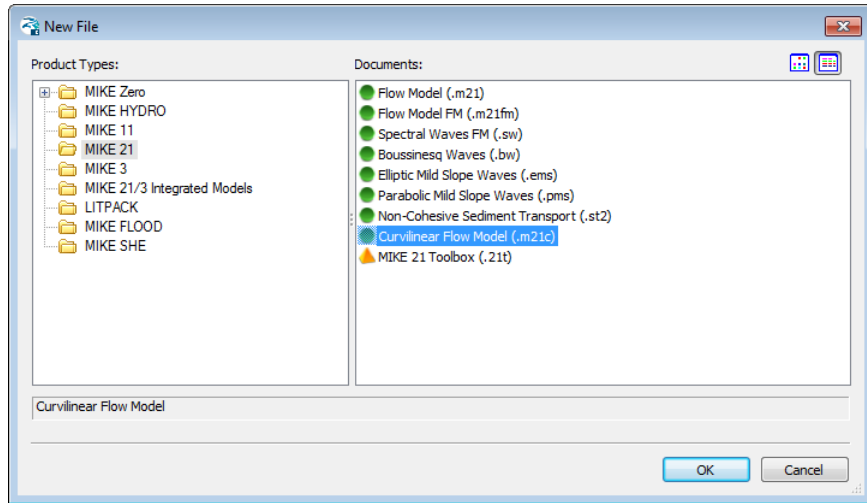

Figure 6.5 Creating a new MIKE 21C simulation file in MIKE Zero

This will create the MIKE 21C definition file (extension .M21C), which has the following structure:

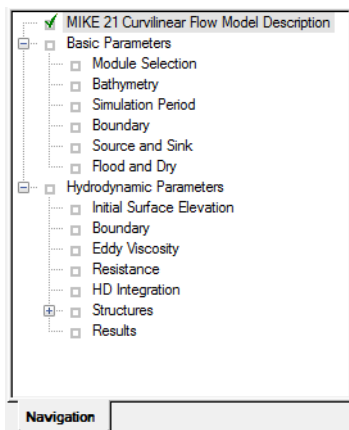

Figure 6.6 MIKE 21C definition file

To define the model simulation, each sub-menu needs to be filled in with appropriate information. When this has been done, a green tick appears in the relevant box. If there is an error, a red cross is shown.

The basic parameters needed are as follows:

Module selection - hydrodynamics only

This is a HD simulation. Later simulations will also include river morphology.



Bathymetry - cold start

In this menu the model bathymetry needs to be defined, which includes the bathymetry file (straight_bathy.dfs2) and grid coordinate file (trench_grid.dfs2). This is a cold start simulation, meaning that the model will be 'warmed up' from an initial condition.

Simulation period

The simulation period is for 2880 time-steps at a time-step interval of 300 sec, which is 10 days. As this is a cold start, a warm up period of 288 time-steps (1 day) is specified. During this period the boundary conditions will gradually ramp up from zero to the specified boundary conditions (see Hydrodynamic Parameters below).



Note that this time-step selected in this dialogue will only apply to the HD model if a Fully dynamic HD model is selected under the HD Integration dialogue, while for a Scaled dynamic HD model the HD time-step will be given in that HD Integration dialogue. The latter is the case here, so the time-step of 300 sec is not actually used for solving the HD equations, and it can be said with certainty that 300 sec HD time-step would not work for this situation (the HD model would become unstable).

Boundary

This menu locates the grid cells where boundary conditions are to be specified. In this case the boundaries have been defined in the bathymetric file, so can be simply set here as "Program detected".

Source and sink

No sources or sinks are specified.

Flood and dry

This model is not expected to experience wetting or drying (the entire model domain will remain wet). However, in simulations with changes in bed level occurring (which is the majority of river morphology applications) wetting and drying can occur. As a 'just in case' precaution wetting and drying can be left on with the default values (0.2 m drying depth and 0.3 m wetting depth).

MIKE 21C has been designed to always use flooding and drying in morphological simulations for the simple reason that flooding and drying can usually not be ruled out when the bed level changes. Therefore the GUI will give a validation error if a morphological simulation does not have flooding and drying activated.

The hydrodynamic parameters needed are as follows:

Initial surface elevation

The initial horizontal surface elevation is a constant value of 0.0 m.



Boundary

The Boundary Menu in the Basic Parameters defines the locations of the boundaries. This menu defines the type of conditions are at the boundaries. This simulation uses a constant upstream discharge (or flux) of 350 m³/s and a constant downstream water level of 0.0 m.

Source and sink

None.

Eddy viscosity

A uniform eddy viscosity is applied, with a constant of 0.5 m²/s.

Resistance

A uniform Manning's M bed resistance value of 50 m^{1/3}/s is applied.

HD integration

The purpose of this exercise is to develop a morphological simulation. The morphological time scale is much longer than the hydrodynamic time scale. A special feature of MIKE 21C will be used to scale the hydrodynamic simulation to fit the morphological simulation. The boundary conditions are constant, so if only considering a hydrodynamic simulation then this is a steady state problem. But, as bed levels change, hydrodynamic conditions change. This will be a slowly varying state, but dynamic nonetheless. If performing a fully dynamic simulation, a time-step of the order of 1 s would be appropriate for the given Courant conditions. However, we are expecting morphological changes to occur over a time scale of several weeks. This means that if a fully dynamic simulation was used, the simulation would need up to a million time-steps, which can be simulated, but unnecessarily cumbersome. Instead, set the HD Integration type to be Scaled Dynamic and the HD time-step equal to 1 s, which gives a simulation scale factor of 300. This means that the HD engine will use a 1 sec time-step when in reality 300 sec pass by, but this is acceptable because the HD solution has to adapt to slow morphological changes. This permits much longer time-steps, however any hydrodynamic response in the system will behave as if the simulation is being run at a 1 s time-step.

Results

Specify a hot start file called "straight_hot.dfs2". For a hot start simulation there is no need to write an HD result file, except for the purpose of checking the results. Write the HD file called "straight_hot_hd.dfs2", and write it for every 24 hours (i.e. store every 288 time-steps).

When all information required for a simulation has been defined, every box will contain a green tick. The validation window on the bottom of the dialogue will also have a 0 error message. Save the MIKE 21C file as "straight_hot.M21C", then run the simulation using the Menu commands "Run -> Start simulation...".



Once the simulation has completed, check the results written in “straight_hot_hd.dfs2”. Has the simulation stabilised from the initial warm-up? An upstream flux of 350 m³/s will result in a velocity of approximately 0.6 m/s, while in the trench velocities will decrease to approximately 0.3 m/s. Ensure that this is the case by using the Result Viewer. Note that time series output at selected locations in the model domain is a useful way to do this.

6.2.6 Hydrodynamic simulation - scaled dynamic HD solution

An HD simulation has now been successfully performed, which will be used as initial conditions for the following morphological simulation. The next step is to produce the longer term HD simulation that will form the basis for the morphological simulation.

Take the previous setup file and rename it (“Save As...”) to “straight_hd.M21C”. The Bathymetry will use the hot start file created previously (“straight_hot.dfs2”) instead of the bathymetry file. The simulation period is now 28800 time-steps, which is equivalent to 100 days. For a hot-started simulation you cannot specify the time-step; it is actually imported from the hot-start file. For this simulation a hot start file should not be written, as this would overwrite the hot start file, and that file is needed for the additional simulations. Also, make sure that the HD file is not overwritten by specifying a new name (“straight_hd.dfs2”); write the HD file at the same frequency of 288 time-steps.

Run this simulation and check that the results are steady. An upstream flux of 350 m³/s will result in a velocity of approximately 0.6 m/s. In the trench velocities will decrease to approximately 0.3 m/s. Again, time series output from selected locations within the model will show if this is the case.

The bed shear stress is defined as:

$$\tau = \frac{\rho g V^2}{C^2} \quad (6.7)$$

or in terms of Manning's M:

$$\tau = \frac{\rho g V^2}{M^2 h^{1/3}} \quad (6.8)$$

For a velocity of 0.6 m/s, a depth of 2 m and Manning's M of 50 m^{1/3}/s, the bed shear is approximately 1.2 N/m².



6.2.7 Sediment transport simulation

Once satisfied that the hydrodynamic model is performing satisfactorily, the sediment transport components are added. At this stage it is worth considering the time-steps to be used in the simulations, which include:

- the hydrodynamic time-step
- the morphological time-step, which applies for the sediment continuity equation and all advection-dispersion equations

The hydrodynamic time-step has been discussed previously, and is selected relative to the hydrodynamic (or wave celerity) Courant number, defined by:

$$C_{r,HD} = \frac{(V + \sqrt{gh})\Delta t}{\Delta s} \quad (6.9)$$

where V is local flow velocity, g acceleration of gravity, h local flow depth, Δt hydrodynamic time-step, and Δs local grid cell spacing. Due to the use of implicit solvers for the hydrodynamics the Courant number can be larger than one without introducing instabilities.

Simulations with helical flow and suspended load use an advection-dispersion scheme.

When applying the implicit AD solver, the AD time-step is automatically set internally in the calculation to be the same as the morphological time-step. There is no stability criteria for the implicit AD solver.

The stability criterion for the morphological time-step is related to the bed wave celerity [m/s], which roughly can be estimated as:

$$C_{r,BW} = \frac{5S}{h(1-n)} \quad (6.10)$$

where S is the sediment transport rate m^2/s , h is the water depth (m), and n is the porosity. The constant 5 is estimated as two times the exponent on the Shields parameter in the sediment transport formula, which is 2.5 for the Engelund-Hansen formula. Thus an estimate on the upper limit of the morphological time-step can be made from the condition that the Courant number cannot exceed one:

$$\Delta t = \frac{\Delta x}{C_{r,BW}} \quad (6.11)$$

This estimate may not always be the best choice, and one should in general choose a lower value. The problem is further complicated by the dependence



of the hydrodynamic simulation upon the changing bed morphology, which can destabilise the system.

Open the previous simulation specification file (“straight_hd.M21C”) and use Save As... to save a new specification file (“straight_sediment.M21C”). Update the Basic Parameters - Module Selection to be Hydrodynamics and River morphology. When activating river morphology, the AD scheme selection becomes active and by default set to QUICKEST, but this selection is overwritten when the implicit AD solver is selected later in the process. The menu “River Morphology Parameters” will now appear in the tree view. The menus highlighted below require specific information relating to this simulation:

Starting conditions

The simulation period will be the same as the HD simulation (28800 time-steps), amounting to 100 days. For demonstration purposes, deactivate the Helical flow module in this simulation; there will surely not be any streamline curvature in this case, but in general any morphological simulation should include helical flow. Even if it may seem as if there will never be any streamline curvature in a simulation, it can still be induced by the morphological changes. Set the morphological time-step to 600 sec, which is done by setting the morphological update frequency to 2. The morphological drying depth must be in the range drying depth to flooding depth set under the flood and dry dialogue, and in this case select the drying depth, i.e. set the morphological drying depth to 0.2 m. As already stated the morphological drying depth is not important in this case because the water depth is always much higher than the flooding depth. Use the implicit AD solver, which means that the suspended sediment AD equation will be solved implicitly using the morphological time-step. Set the maximum number of iterations on the AD equation to 10 and use a relaxation factor of 1. Only the Sediment Transport module is activated under the Simulation type selection.

Sediment transport

Only one fraction is simulated. If more fractions are included, the sediment transport model becomes a graded sediment model. With such a model, it is possible to simulate not only bed level changes but also sorting processes. The specified porosity, density and critical Shields stress are typical for a sandy material (see Grain Size below). The bed slope parameters G and s are crucial to accurately simulating transverse bed slope, and subsequently the scour depth. Deflection of the bed load direction $\tan(\nu)$ due to transverse bed slope is defined as, where τ_{*c} is the Shields parameter (non-dimensional bed shear stress) and dz/dn is the transverse bed slope. The values $G = 0.66$ and $a = 0.5$ based on theoretical analyses are used in this simulation (valid for laboratory conditions).

One could note here that the transverse bed slope effect will have no effect, as there are no transverse (relative to the flow direction) slopes in the bathymetry (but there may be in a morphological simulation). However, it is



not possible to activate transverse and longitudinal slope effects separately in MIKE 21C (except by setting $G=0$).

The “Maximum concentration allowed due to erosion” parameter is important for stability, and the default value of $50,000 \text{ g/m}^3$ should work well for this model. $50,000 \text{ g/m}^3$ may sound high for sand, but the purpose is primarily to avoid extreme bed level changes that can occur as a result of unrealistic shear stresses predicted when the water depth is close to the drying depth.

The scale factor on the fall velocity can be used to alter the fall velocity, and it is set to 1 in this model.

Grain size

A constant grain size of 0.1 mm is applied across the entire modelling area. This is a very fine sand/silty material. The threshold between cohesive and non-cohesive material is defined as 0.063 mm, or 0.0625 mm, which is convenient because it is 1/16 mm.

Initial concentration

An initial concentration of suspended sediment of zero is specified. It is noted that the initial concentration is never used for non-cohesive sediment; instead the initial concentration is set internally in the engine to be the equilibrium concentration that can be calculated from the selected suspended load formula.

Dispersion coefficients

Dispersion coefficients influence the rate of dispersion of suspended sediment. If a given application is bed load dominated, the effect of dispersion coefficient is likely minimal. In this case zero dispersion is specified, but this does not mean that the suspended load has zero dispersion. There is in fact already dispersion calculated from profile functions included in the AD equation, and the dispersion selected under the Dispersion Coefficients dialogue will be added to the theoretical dispersion. There is also some numerical dispersion in the numerical scheme used for the AD equation. If a model is exhibiting stability problems, one of the ways to reduce such problems, is to use additional dispersion, but it should be done with caution.

Transport theory

The Engelund-Hansen formula is used for both bed load and suspended load. This formula is a total load formula, which means that factors need to be applied to determine what fraction of the total is bed load and what is suspended load. In this application bed load is the dominant form of sediment transport, which is reflected in the values specified here (0.9 for bed load and 0.1 for suspended load). However, the specified grain size is very fine, so more of the material may be in suspension.

Boundary

Zero bed level change ($dz/dt = 0$) is specified at the boundaries. This boundary condition is demanded, but it has no influence on the results, except for



the calculated sediment load at the upstream boundary. The boundary condition has much more influence in a morphological calculation.

Results

Specify a result file that will contain suspended concentration, bed load, suspended load, total load, bed level and bed level change. The title is “straight_sediment_st.dfs2”. A title can optionally be included in the file definition.

The Shields parameter is defined as:

$$\theta = \frac{\tau}{\rho g (s-1) d_{50}} = \frac{u^2}{C^2 (s-1) d_{50}} \quad (6.12)$$

For the conditions given in this model (HD parameters mentioned previously and $d_{50} = 0.1$ mm and $s = 2.65$), the Shields parameter will be approximately 0.7. The critical Shields parameter is 0.056, so sediment transport will take place. The simulation is using an Engelund-Hansen sediment transport formulation, which gives an expression for sediment transport [m^2/s]:

$$S = 0.05 \frac{C^2}{g} \theta^{5/2} \sqrt{(s-1) g d_{50}^3} \quad (6.13)$$

Thus, a transport rate of the order of $25 \times 10^{-6} m^3/s/m$ is expected for this simulation. Check the results of this simulation - do they reflect this expected transport rate? The suspended transport rate is 10% of the total ($2.5 \times 10^{-6} m^3/s/m$), which gives a suspended sediment volume of $750 \times 10^{-6} m^3/s$ crossing the 300 m wide boundary. Considering the volume of water entering the boundary ($360 m^3/s$) and a relative sediment density of 2.65, the suspended sediment concentration should be $5.5 g/m^3$. Does this match the simulated results?

6.2.8 Morphological simulation

Once satisfied that the sediment transport simulation is performing satisfactorily, the morphological update can be included. Open the previous simulation (“straight_sediment.M21C”) and save the specification file as “straight_morphological.M21C”. The menu “River Morphology Parameters” menu requires the following updates for this simulation:

Starting conditions

Include Morphological Update in this simulation, which causes an additional menu item to appear in the tree view. Helical flow should also be activated now that we may see streamline curvature due to the morphological changes, which also adds the Helical flow dialogue.

Helical flow

Use the default parameters for the helical flow.

Morphological update

Specify zero layers. This means that the bed is an infinitely deep source of sediment (fully alluvial) with characteristics specified in the previous menu. It also means that the equilibrium layer thickness parameters are not used, as these are only relevant when the local sediment supply can become finite. Keep the Update Bathymetry checkbox activated and set all the Maximum parameters to zero (this deactivates the parameters).

Results

Write the ST results to "straight_morphological_st.dfs2", and include in the output file the items "Bed level" and "Bed level change". Also remember to write a new HD result file ("straight_morphological_hd.dfs2").

Look at the results from the simulation. A useful output tool in this case due to the one-dimensional nature of the problem is to produce a longitudinal profile along the length of the model ("Profile series from 2D files" in the MIKE Zero Toolbox). The following plot shows the bed level profile at several stages in the simulation.

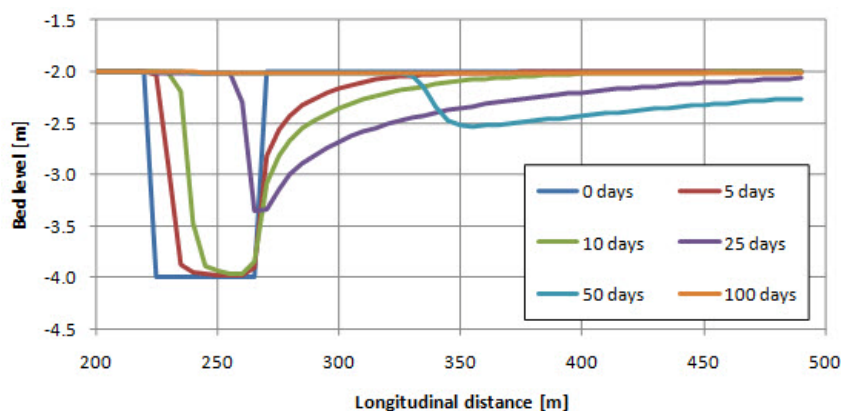

Figure 6.7 Simulated longitudinal bed level profiles after 0, 5, 10, 25, 50 and 100 days

As shown, there is backfilling at the upstream end of the trench. At the same time there is scouring at the downstream end, which produces a migration of the trench in the direction of flow. The trench continues to migrate downstream, but also becomes shallower and more elongated. By the end of the simulation the trench is really no longer a trench, but more like a "smeared" depression.

6.2.9 Going further

The morphological model is complex. There are a number of parameters that can be modified within justifiable ranges that can produce significantly differ-



ent results. Always conduct sensitivity tests when in doubt about parameter values.

Upstream sediment transport

Modify the upstream boundary condition. Set the ST boundary to be a constant inflow of sediment at a rate of $0.025 \text{ m}^3/\text{s}$, which is set by changing the upstream morphological boundary condition to “Transport, constant”, which then requires the specification of the transport [m^3/s].

It is noted that the prescribed upstream load is higher than the sediment transport calculated from the model, and hence there will be sedimentation in the system. The sedimentation happens until the sediment transport capacity in the system is the same as the prescribed inflow. The opposite situation can also be simulated, namely prescribing a lower sediment inflow compared to the transport capacity, and this will cause scouring in the system until the sediment transport capacity is down to the inflow. This erosion/sedimentation mechanism associated with imbalances between the sediment inflow and transport capacity is very important for practical applications, and easily simulated with MIKE 21C.

The increased sediment transport also means that the morphological Courant number increases. If attempting to run this model with the same time-steps, as used in the first morphological simulation, it turns out that the model is no longer stable. So it can be said that the 10 min morphological time-step used for the first run, does not work for this run. Instead of the 300 sec time-step, we now need 120 sec, and that in principle requires a new hot-start simulation. However, there is a trick that can be applied to circumvent the cumbersome rerunning of a hot-start simulation:

- Make a copy of the straight_hot.dfs2 file, call this straight_hot_120sec.dfs2
- Load the straight_hot_120sec.dfs2 file into MIKE Zero
- Go to the Edit menu and find the menu item Time steps...
- Change the Time Step Interval to 120 sec (from 300 sec)
- Save the straight_hot_120sec.dfs2 file

Now you have a hot-start file that will give a time-step of 120 sec when loaded into a MIKE 21C specification. It should be noted that this approach is only recommended for a steady-state hot-start file, while for a hot-start file representing dynamic conditions, this may cause problems.

Now the simulation can be set up with a morphological time-step of 240 sec (4 min) instead of 10 min, which should give a stable solution. Make sure you change the output frequencies to still yield daily output, and that the simulation still runs over 100 days.

Run the simulation and check the results, remember to write new specification and result files.

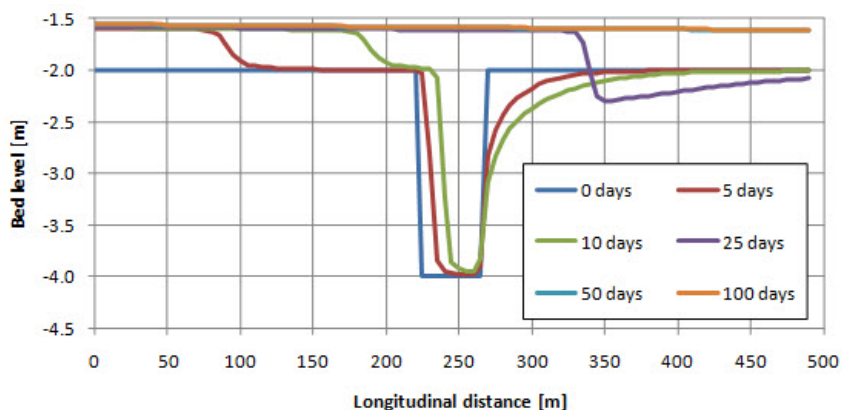

Figure 6.8 Simulated longitudinal bed level profiles with 0.025 m³/s prescribed sediment inflow after 0, 5, 10, 25, 50 and 100 days

The results show (see Figure 6.7) that the constant inflow of sediment creates a rise in bed level that propagates from the upstream boundary. This rise continues until by the end of the simulation the entire model domain, including the trench, has been completely filled in. At the end of the simulation the bed level has increased to almost -1.5 m, which is 0.5 m sedimentation. With that increase in bed level and the water level still equal to 0 m at the downstream boundary, the sediment transport in the area has been increased to match the sediment inflow.

Change in bed load / suspended load

Modify the ratio between bed load and suspended load to 30% bed load and 70% suspended load (previously 90% and 10%).

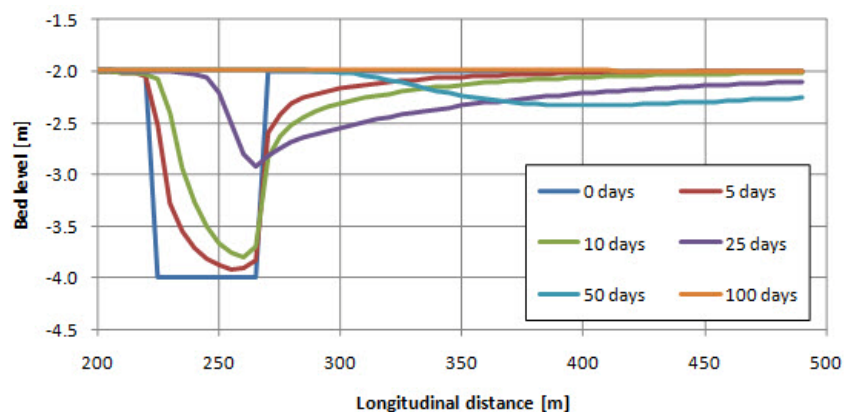

Figure 6.9 Simulated longitudinal bed level profiles with 30% bed load and 70% suspended load after 0, 5, 10, 25, 50 and 100 days



Oblique Channel

The second bathymetry is a trench aligned at 60° to the direction of flow. Repeat the simulations above using the second bathymetry file, called “oblique_bathy.dfs2”. The curvilinear grid is the same as before (“trench_grid.dfs2”). Remember that the hot-start HD simulation also needs to be performed again.

The results from this simulation show a similar pattern to the simulations with a straight channel. Figure 6.10 shows the bed level profile along the centre line of the model (blue line) and along each lateral boundary of the model (orange and purple lines), at the same stages in the simulation as previously presented.

The profile along the centre line of the model appears similar to the previous simulation. Notice however the differences in the profiles along the lateral boundaries. The end of the trench furthest away from the upstream boundary has remained deeper than the rest of the trench. The end closest to the upstream boundary is shallower. This effect is caused to a hydrodynamic effect in this system - there is a flow component in the direction of the trench. This flow component appears to be creating a sediment movement along the trench, rather than just over it as was the case with the previous geometry. To see exactly how this phenomenon is occurring, check the hydrodynamic results. Is there a redistribution of flows along the trench? Is there a similar pattern seen in the sediment transport?

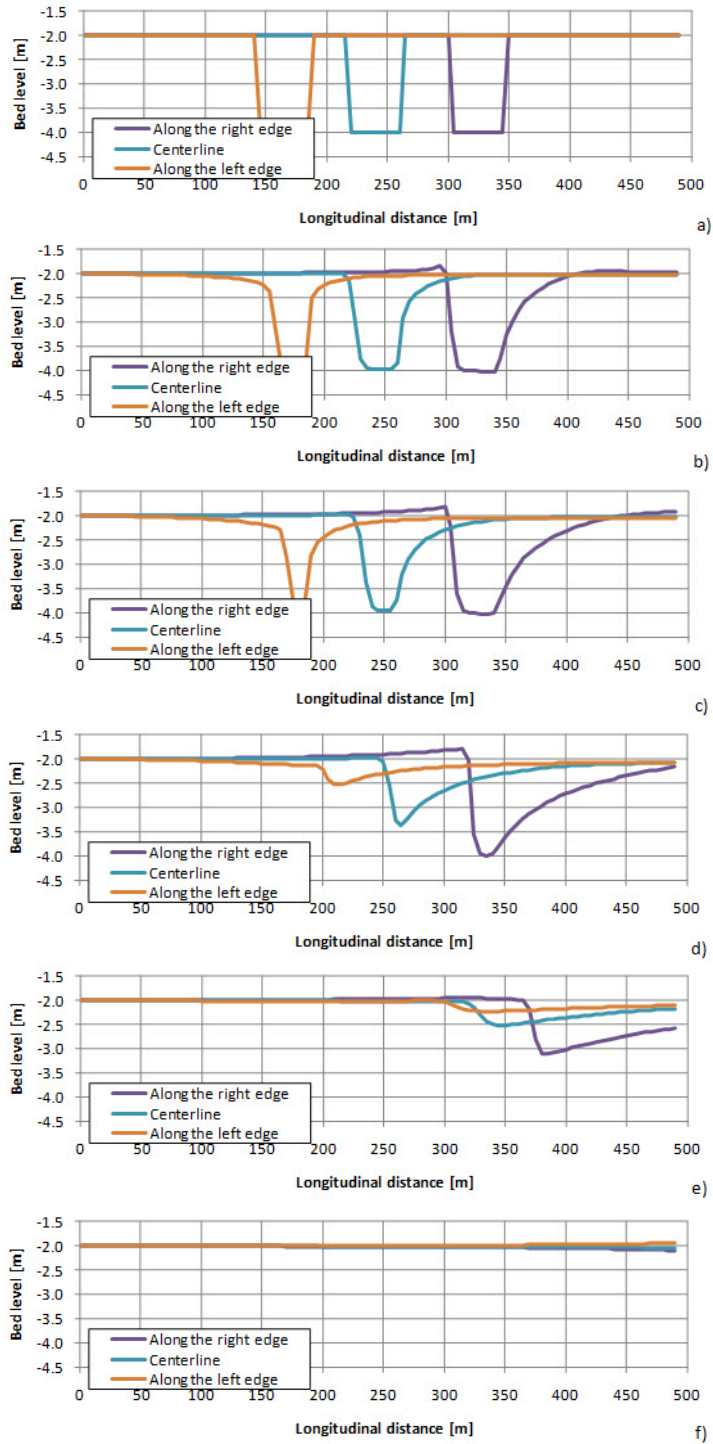

Figure 6.10 Simulated longitudinal bed level profiles for an oblique trench after (a-f) 0, 5, 10, 25, 50 and 100 days



6.3 Morphological Model of a U-Flume

6.3.1 Introduction

This tutorial describes the development of a morphological model of a curved channel or river bend. The model is based on the curvilinear MIKE 21C modelling system. The setup is of a U-shaped flume, which is extensively used at Delft University for studying river morphology and is subsequently described in a number of PhD theses and papers. Important parameters and data files for the MIKE 21C model are described and discussed in the following step by step tutorial.

6.3.2 Before starting this tutorial

This is a tutorial and some of the files are pre-prepared. In particular, the curvilinear grid has already been generated. If you want to learn about creating a curvilinear grid using M21GG, see the M21GG tutorial. Further, the MIKE 21C model uses the **MIKE Zero** model environment. It is assumed that you are familiar with this interface and are aware of the various file types used in MIKE Zero. In particular, references are often made to the **Result Viewer**, used to visualise model results.

Files to start with

There are only two files that you need to start this tutorial - the rest will be created. These files are the descriptions of bathymetry and the grid coordinates:

- **flume_bathy.dfs2** - This file contains the bed levels at each grid point.
- **flume_grid.dfs2** - This file contains the curvilinear coordinates of the grid.

Use the **Result Viewer** to look at these files.

6.3.3 Problem definition

Model development will follow the procedure:

- Define the problem
- Model Bathymetry
- Create a HD hot start simulation, which will provide initial conditions to the main simulation
- Simulate helical flow
- Simulate bed load and suspended load
- Simulate morphology

6.3.4 Model bathymetry

The model is a U-shaped flume (total length about 20 m), initially with a constant slope (0.35%), width (approx. 0.5 m) and depth (approx. 5 cm). The bed level varies from approximately -0.85 mm upstream to -118.8 mm downstream. The flume width is represented in the model with 12 grid points, where the first and last points describe the banks. This means that only three points describe the lateral flow (and sediment) distribution. In the longitudinal direction, there are 140 points.

The model geometry is shown in Figure 6.11.

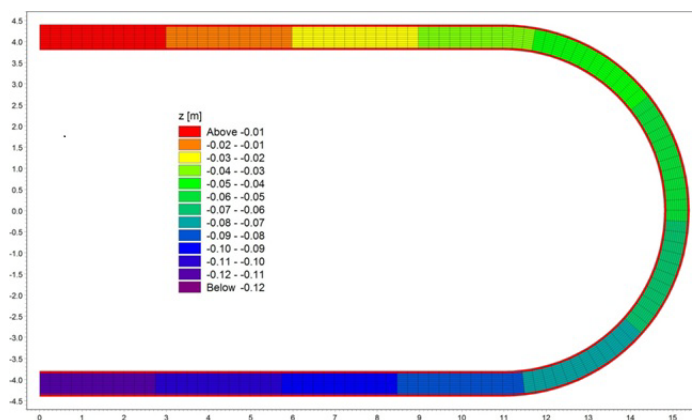

Figure 6.11 Bed level variation in the U-Flume model bathymetry

The model geometry can be viewed in two ways. The first way is using the M21C Grid Generator (m21gg.exe, described in the m21gg tutorial) or in the Result Viewer within the MIKE Zero Interface. The model bathymetry is located in the file “**flume_bathy.dfs2**”. The model grid coordinates are located in the file “**flume_grid.dfs2**”.

6.3.5 Hydrodynamic hot start simulation

The term “hot start” means to use a previous simulation as the initial conditions for a subsequent simulation. Create a new simulation file in MIKE Zero, using the menu commands “**File -> New**”:

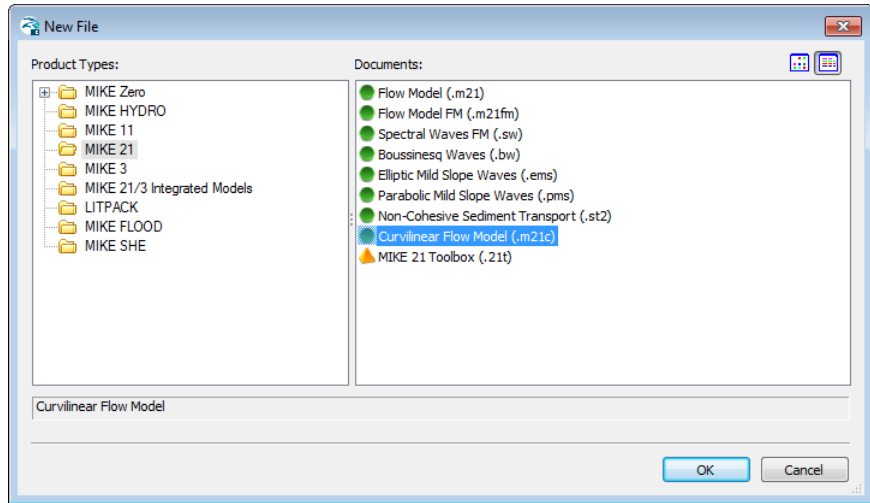

Figure 6.12 Creating a new simulation file in MIKE Zero

This will create the M21C definition file, which has the following structure:

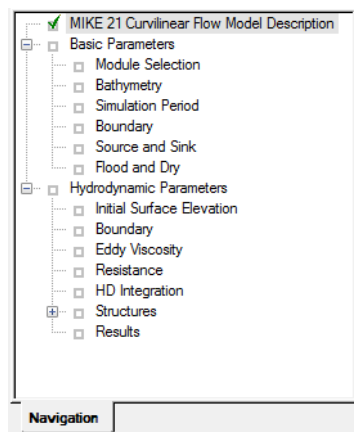

Figure 6.13 Structure of M21C definition file

To define the model simulation, each sub-menu needs to be filled in with appropriate information. When this has been done, a **green** tick appears in the relevant box. If there is an error, a **red** cross is shown.

The basic parameters needed are as follows:

Module selection - hydrodynamics only

This is a HD simulation. Later simulations will also include river morphology.



Module Selection

Select Module

Hydrodynamics only

Bathymetry - cold start

This simulation creates **hot start** information for the next simulation - so this simulation is a **cold start**. In this menu the model bathymetry needs to be defined, which includes the **bathymetry** file and **grid coordinate** file.

Bathymetry

Type

Cold start
 Hot start

Curvilinear grid

	Bathymetry		Grid	
1	C:\Data\...\U_flume\flume_bathy.dfs2	...	C:\MIKE21Cl...\U_flume\flume_grid.dfs2	...

Simulation period

The simulation period is 1 hour or 3600 s at a **time-step of 1 s (3600 time-steps)**. As this is a cold start, a **warm up period** of 1200 time-steps is specified. During this period the boundary conditions will gradually ramp up from zero to the specified boundary conditions (see Hydrodynamic Parameters below). Warm up is generally a good idea when especially water level boundary conditions deviate from the initial surface elevation. Make this simulation start at 23:00 (11 pm) on 31 December 1999, which will make the simulation end 1 January 2000 at midnight. The end time of the simulation is written to the hot start (which we will call flume_hot.dfs2) file and this point in time will be used at starting time for any simulation using the hot file.

The user may notice that there is no Courant number estimation, as in MIKE 21 Classic, in MIKE 21C. The reason is that the Courant number in MIKE 21 Classic is estimated by assuming that the water level is around zero (reasonable for coastal and ocean hydrodynamics), which is not a reasonable assumption in a river. There is essentially no way to tell what the water level will be in a simulation, and therefore there is also no way to tell before running a MIKE 21C model what Courant numbers to expect. Therefore the Courant number estimation is not available from the MIKE 21C editor.



Boundary

This menu defines the boundary conditions. In this case the boundaries have been defined during grid generation, so can be simply set here as **“Program detected”**, which means that the open boundaries are simply the connected cells along the edge of the bathymetry for which the bathymetry is below the prescribed true land value of 10 m (check the custom blocks – information written in the header - for the dfs2 file to verify this value; it is the fourth value of seven in the custom block called M21_Misc).

Source and sink

No sources or sinks are specified.

Flood and dry

This model is not expected to experience wetting or drying (the entire model domain will remain wet). However, MIKE 21C always requires flooding and drying activated for morphological simulations. Therefore set the drying and flooding depths to 0.001 m and 0.003 m.

The hydrodynamic parameters needed are as follows:

Initial surface elevation

The initial horizontal surface elevation is a **constant value of 0.04 m**.



Initial Surface Elevation

	Given as:	Value
1	Constant value	0.040000

Boundary

The Boundary Menu in the Basic Parameters defines the locations of the boundaries. This menu defines the type of conditions are at the boundaries. This simulation uses a constant upstream **discharge** of **0.0057 m³/s** and a constant downstream **water level** of **-0.07066 m**.

Boundary		
Boundary 1 : (0,1) - (0,10)		
Formulation:	Flux	
Constant:		0.005700
FAB type:	12	
No tilting		0
No user defined flow direction		
Boundary 2 : (139,1) - (139,10)		
Formulation:	Level	
Constant:		-0.070660
FAB type:	12	
No tilting		0
No user defined flow direction		

Eddy viscosity

Eddy viscosity represents sub-grid turbulence, and is of more importance when the horizontal grid spacing is much larger than the water depth (this is not the case here), and the small transverse grid spacing of 5 cm is in the same order of magnitude as the water depth. The considered case is therefore surely friction dominated (the dominating forces are friction and gravity), but some eddy viscosity is good to add for better stability, in fact it is difficult to run this particular model without viscosity. Therefore add an eddy viscosity of 0.002 m²/s.

Eddy Viscosity	
Given as	Constant Value
Type of Formulation	Velocity based
Viscosity	
1	0.002000

Resistance

Bed resistance was determined from model calibration (performed separately) to be a constant Chezy number of **18.7 m^{1/2}/s**.



Resistance					
Values given as: <input type="text" value="Chezy numbers"/>					
	Format	Value	Filename		Pier res.
1	Constant	18.7000		<input type="checkbox"/>	<input type="checkbox"/>

HD integration

This simulation is a scaled dynamic simulation with a general time-step of 1 sec (selected under **Simulation Period**), while a lower time-step will be used for the HD model. Scaled dynamic simulations are particularly useful in a case like the present because of the constant boundary conditions, which mean that the hydrodynamic solution only has to adapt to changes in the morphology and not to the boundary conditions. Therefore a dynamic HD model would actually be overdoing the HD simulation compared to what is required; adaptation to morphological changes (notably realignment of the flow as the bend scour and point bar develop). In the case of a scaled dynamic HD model, the HD time-step should be selected as the largest time-step that gives a stable HD solution; this is usually found by trial and error. For this hot start simulation, an HD time-step of 0.1 sec works. This actually means that the 1 hour simulation time selected under Simulation Period becomes 6 minutes actual time experienced by the hydrodynamics.

HD Integration	
<p>Time-track information</p> <p>General time-step: <input type="text" value="1"/> [sec]</p>	<p>Quasi-steady</p> <p>Momentum</p> <p>Time-step: <input type="text" value="30"/> [sec]</p> <p>Parameter: <input type="text" value="0.8"/></p> <p>Stop criterion: <input type="text" value="1e-008"/> Solver: <input checked="" type="radio"/> SSIP <input type="radio"/> Line SOR</p> <p>Max iterations: <input type="text" value="10"/></p>
<p>Integration type</p> <p><input type="radio"/> Fully dynamic</p> <p><input checked="" type="radio"/> Scaled dynamic</p> <p><input type="radio"/> Quasi-steady</p> <p><input type="radio"/> Steady</p>	<p>Pressure</p> <p>Time-step: <input type="text" value="30"/> [sec]</p> <p>Parameter: <input type="text" value="1.2"/></p> <p>Stop criterion: <input type="text" value="1e-008"/> Solver: <input type="radio"/> SSIP <input checked="" type="radio"/> Line SOR</p> <p>Max iterations: <input type="text" value="10"/></p>
<p>Scaled dynamic</p> <p>HD time-step: <input type="text" value="0.1"/> [sec]</p> <p>Scale factor for the simulation: <input type="text" value="10"/></p>	

Results

The only required output from this simulation will be a **hot start** file. The name of this file is specified here (call it "**flume_hdhot**"). A title can optionally be included in the file definition.

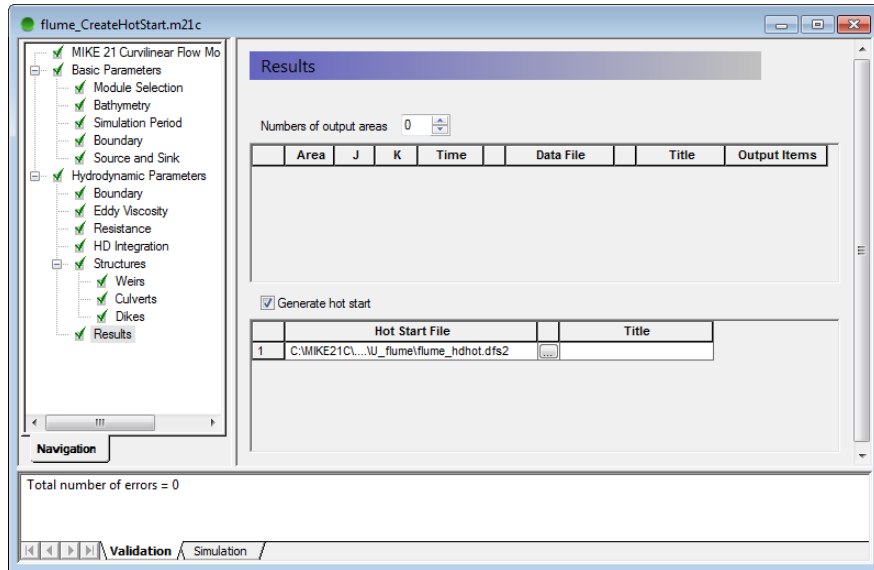

When all information required for a simulation have been defined, every box will contain a green tick. The **validation** window on the bottom of the dialogue will also have a 0 error message. Save the M21 file as “**flume_cold-start.M21C**”, then run the simulation using the Menu commands “**Run -> Start simulation ...**”. The simulation will then launch and the progress can be followed in the lower part of the window.

6.3.6 Simulation of helical flow

The hot start file has now been created, which will be used as initial conditions for a simulation with helical flow.

Open the previous simulation (“**flume_coldstart.M21C**”) and rename the file (use the menu “**File -> Save As...**”) “**flume_helical.M21C**”. The previous setup can now be modified to create the helical flow simulation.

The basic parameters to be modified from the previous setup are as follows:



Module selection - hydrodynamics and river morphology

Bathymetry - hot start

Instead of using a bathymetric file, specify the hot start result file from the previous simulation called “**flume_hot.dfs2**”. The same grid coordinate file is used. When changing from a cold start to a hot start, the user will be asked whether the boundary conditions should be recalculated to the new bathymetry information (stored in the hot start file). Since in this case the bathymetry is actually the same, while we are simply switching to a hot start, the boundary conditions are the same as for the cold start run. If recalculating the boundary definitions, the boundary conditions (discharges and water levels) will also have to be redefined, but this is not done when saying no to recalculate the boundary conditions. In this way the boundary conditions from the cold start can be reused.

	Bathymetry		Grid	
1	C:\MIKE21C\...\U_flume\flume_hdhot.dfs2		C:\MIKE21C\...\U_flume\flume_grid.dfs2	

Simulation period

This simulation uses the **same time-step** of 1 sec as the hot start simulation and will run for **3600 time-steps** (1 hour). Note that the time-step is imported from the flume_hot.dfs2 hot start file and cannot be edited (grayed out). The helical flow is calculated as part of the morphology, and is therefore time-true i.e. it experiences 1 hour, while the HD calculation only experiences the same 12 minutes as in the hot start simulation. This means that the helical flow will have 1 hour to converge, which is plenty, while the HD solution is already steady due to the hot start simulation.



Simulation Period

Simulation

Time step range: First: 0 Last: 3600

Time step interval: 1 [sec]

Simulation start date: 01-01-2000 00:00:00

Simulation end date: 01/01/2000 01:00:00

Warm-up Period

Time step range: First: 0 Last: 600

There is only one hydrodynamic parameter to modify:

Results

A **result** file is specified. Name the file “**flume_hdhelical**”. A title can optionally be included in the file definition. Note that there will *not* be a hot start file created in this simulation.

Numbers of output areas: 1

Area	J	K	Time	Data File	Title	Output Items	
1	1	0-139,1	0-11,1	0-3600,1	\\U-flume\flume_hdhelical.dfs2	helical flow	Fluxes and Levels

The river morphology parameters need to be defined in this simulation

The menus highlighted below require specific information relating to the helical flow simulation. Other menus may need to be “touched”, but not activated or edited:

Starting conditions

The simulation period will be the same as the HD simulation (3600 time-steps). The simulation uses helical flow only, so the other modules remain unselected. An Implicit AD model is used, which means that the helical flow adaptation (AD) equation will be solved implicitly. Allow Maximum iterations 10 to be conducted on the helical flow adaptation equation at each time-step with a Relaxation factor of 1, and use the default stop criterion of 10^{-6} .



Starting Conditions

Simulation period

Time step range

First:

Last:

Morphological time-step

Time-step frequency: x HD dt

Morphological time-step: [s]

Morphological drying depth: [m]

Sub-modules

Helical flow

Sediment transport

Planform

Alluvial resistance

Morphological Update

Implicit AD solver

Maximum iterations:

Relaxation factor:

Stop criterion:

Log output

Log frequency: x ST dt

Time period: [s]

Helical flow

Helical flow intensity is defined as the deviation, $\tan \delta$ of the shear stress at the bed. It is approximately equal to $10 \cdot h/R$ (though a little less for small-scale models), where h is depth and R is bend radius. For this application, with 4 m radius and 4 cm depth, helical flow intensity should be of the order of 0.1. Ideally, the helical flow intensity should be calibrated against measurements. If unavailable, indirect calibration can be achieved (though not in this case) by investigating transverse bed slope in a morphological simulation, although this can be difficult due to the dependency of the transverse slope on the sediment transport model. Set the calibration constant value (α , with a recommended range between 0.4 and 1.2) to 1, and the maximum value = 1 for $\tan \delta$ (i.e. 45 degrees maximum deviation); these are the default values. For more information on helical flow, check the reference manual.

Helical flow

Area	Given as:	Value
1	Constant value	1.000000

Maximum Helical Flow ($\tan \nu$):



Results

Specify a result file that will contain the helical flow intensity, called “**flume_helical**”). A title can optionally be included in the file definition. There should now be no red ticks on any menus. Save the simulation file and execute using the menu commands “**Run -> Start simulation...**”.

Result

Number of Output Areas: 1

	Area	J	K	Time		Data File	Title
1	1	0-139,1	0-11,1	0-3600,1	<input type="checkbox"/>	21\m21cU_flume\flume_h	

Save properties

- Helical flow intensity
- Single fraction no.: 1
- Single layer no.: 1
- Bed load
- Suspended load
- Concentration of sediment
- Total load
- Water Surface Elevation
- Net sedimentation
- Bed level
- Bed level change
- Bed resistance
- Bank erosion
- Mean grainsize
- Layer thickness
- Shear stress

Save for all fractions and layers

- Layer thickness
- Concentration
- Sediment transport

Fractional output

- Fractional layer thickness

6.3.7 Results

There are two output files from this simulation - the hydrodynamic (HD) results and the helical flow results. To view these result files, use the Result Viewer. Figure 6.14 shows the HD model results at the last time-step (3600), showing the current speed as contours and the velocity field as vectors. Note how the highest current speeds are located along the inner bank due to the shorter distance (this becomes different when bend scour and point bar develop).

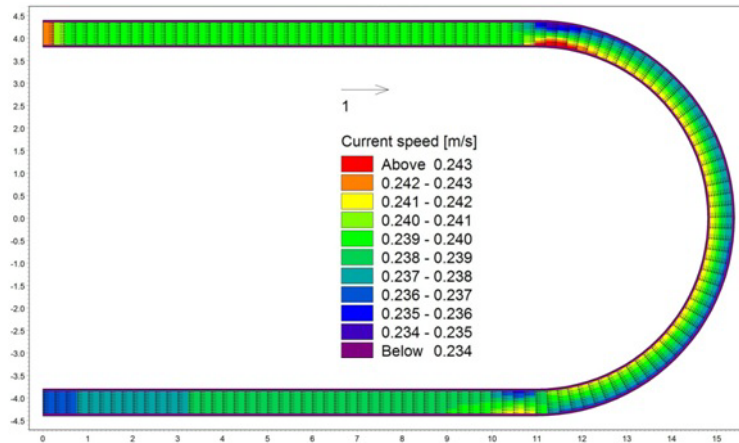

Figure 6.14 HD model results at the last time-step (3600)

Using a new Result Viewer window, helical flow results at the last time-step can also be presented.

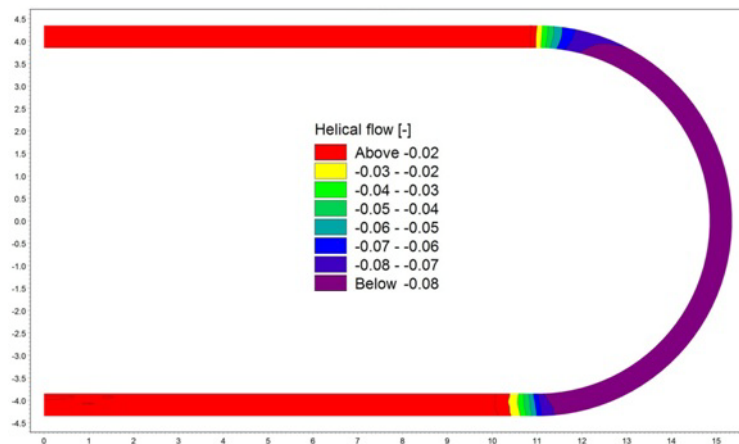

Figure 6.15 The helical flow results at the last time-step shown in the Result Viewer window

There is an adaptation length included in the helical flow calculation (which is why an advection-dispersion equation is solved), caused by the abrupt change in channel curvature between the straight and curved sections in the U-flume. To look at this further, longitudinal profiles of helical flow can be extracted from the model results. Extract line series along the inner and outer banks of the flume at the last time-step. The Cartesian coordinates (not curvilinear) for the lines are (0,1)-(139,1) and (0,10)-(139,10). This can be done using the MIKE Zero Extraction tool, or simply by copying from the dfs2 to a spreadsheet:

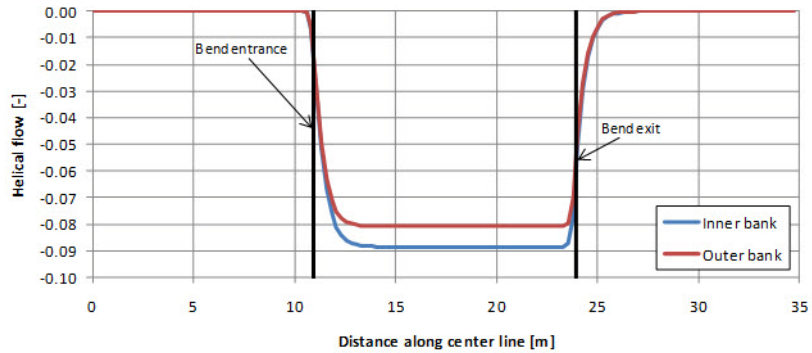

Figure 6.16 Longitudinal profile of helical flow

The flume bend starts around 11 m from the upstream boundary. The flume bend ends the same distance from the downstream boundary, which is actually at 24 m (total length 35 m). The delay at the start and end of the curved reach is evident from these plots; the helical flow adapts gradually to the change in curvature over a relatively small distance. This delay length is important for simulating overshooting and undershooting phenomena in bend scour development.

MIKE 21C uses the adaption length (see Olesen, 1987):

$$\lambda_{sf} = \frac{1,2hC}{\sqrt{g}} \quad (6.14)$$

With a water depth around 0.05 m and Chezy number 18.7 m^{1/2}/s, the adaptation length becomes 36 cm. This adaptation length scale can be seen in Figure 6.16.

6.3.8 Simulation of bed load, suspended load and morphology

Simulation of helical flow alone is rarely performed. Nevertheless, the previous simulation is a useful step for illustrating the modelling process and highlighting its capabilities. A morphological simulation is the next step, which includes hydrodynamics, helical flow, sediment transport (bed load and suspended load) and morphological update.

Close to the flume bed, the sediment transport direction is a function of not only the bed shear force direction but also the difference between the gravitation force direction and the normal force direction. Thus, on a sloping riverbed, bed load tends to move downhill. In a channel bend in morphological equilibrium, the helical flow effect (moves sediment towards inner bank) is balanced with the transverse bed slope effect (moves sediment towards outer bank).



Open the previous simulation (“flume_helical.M21C”) and rename the file to (use the menu “File -> Save As...”) “flume_morph.M21C”. The previous setup can now be modified to create the morphological simulation. The Basic Parameters remain the same as those specified previously. The only Hydrodynamic Parameter to modify is the Results - change the output file name to “flume_hd_morph.dfs2”. Changes are required to the River Morphology Parameters:

Starting conditions

The simulation period will be the same as the previous simulation (3600 time-steps). This simulation uses Helical Flow, Sediment Transport, Alluvial Resistance and Morphological Update. The river morphology (RV) time-step is 10 sec. This means that the RV module is activated every 10 HD time-steps. The AD constants are as specified in the previous simulation.

Sediment transport

Only one fraction is simulated. If more fractions are included, the sediment transport model becomes a graded sediment model. With such a model, it is possible to simulate not only bed level changes but also sorting processes.

The specified porosity ($n=0.35$), density ($s=2.65$) and critical Shields parameter ($\theta_c=0.056$) are typical for a sandy material (see Grain Size below).

The bed slope parameters G and a are crucial to accurately simulating transverse bed slope, and subsequently the scour depth. Deflection of the bed load direction $\tan(\nu)$ due to transverse bed slope is defined as $\tan \nu = G \cdot \theta^{-a} \cdot dz/dn$, where θ is the Shields parameter (non-dimensional bed shear stress) and dz/dn is the transverse bed slope. The values $G=0.66$ and $a=0.5$ based on theoretical analyses (Talmon, 1990) are used in this simulation. Note that the default value of G used in MIKE 21C is $G=1.25$, which corresponds to field conditions, while $G=0.66$ correspond to laboratory conditions and therefore reasonably applied in this simulation.



The longitudinal slope coefficient (s), which has a default value of 5, is not important for the present case. The longitudinal slope coefficient is applied such that the longitudinal bed load becomes the bed load magnitude (calculated from the chosen bed load formula) multiplied with the modification factor $(1 - s \cdot dz/ds)$. The longitudinal bed slope effect is important for the stability of the model, but the value of s in the present case has little impact on the results, unless a very high value is chosen.

Sediment Transport

Number of fractions: Use Egiazaroff hiding function

	Component Name	Type	Porosity	Density	Crit.Shield P.
1	Fraction 1	Non-cohesive	0.350000	2.650000	0.056000

Bed slope effect

Transverse slope coefficient:

Transverse slope power:

Longitudinal slope coefficient:

Fall velocity modification

Factor on fall velocity:

Maximum concentration allowed due to erosion [g/m²]

Grain size

A constant grain size of 0.088 mm is applied across the entire modelling area. This is a very fine sand/silty material. The threshold between cohesive and non-cohesive material is often defined as 0.063 mm or 0.0625 mm, the latter being a convenient definition because it is 1/16 mm.

Grain Size

Area	Type	Value	File Name
	Component : Fraction 1		
1	Constant value	0.088000	



Initial concentration

An initial concentration of suspended sediment of zero is specified. Note that the prescribed initial concentration is never used for non-cohesive sediment, instead MIKE 21C will set the initial concentration of any non-cohesive sediment fraction with suspended load to be equal to the initial equilibrium concentration calculated from the selected suspended sediment transport formula. Prescribing the initial concentration really only makes sense for cohesive sediment.

Initial Concentrations				
Area	Type	Value	File Name	
Component : Fraction 1				
1	Constant value	0.000000		

Dispersion coefficients

Dispersion coefficients influence the rate of dispersion of suspended sediment. If a given application is bed load dominated, the effect of dispersion coefficient can be minimal. In this case zero dispersion is specified. This means that advection (and a very small amount of numerical dispersion) is the suspended sediment transport mechanism.

In addition to the dispersion that can be prescribed by the user in this fashion, there is also dispersion originating from the profile functions, as explained in the MIKE 21C Scientific Documentation. The theoretical dispersion is fairly substantial in the flow direction and relatively small across the streamlines, and hence one can influence primarily the transverse suspended load with additional dispersion. It is also noted that the dispersion prescribed in this way does not apply to the helical flow.

Adding dispersion to the helical flow advection-dispersion equation (which is usually only an advection equation) can be done with the RV Option `AD_Additional_Dispersion`, e.g. adding 0.01 m²/s:

```
[RIVER_MORPHOLOGY_MODULE]

[OPTION_PARAMETERS]

    AD_Additional_Dispersion = 0.01

EndSect // OPTION_PARAMETERS
```

If using this option, the additional dispersion is added to both the suspended sediment as well as helical flow advection-dispersion equations. If experiencing an irregular helical flow pattern, i.e. wiggles, the problem can potentially be solved by adding dispersion to the helical flow adaption equation, if the problem is not a too high morphological time-step.



Dispersion Coefficients

Dispersion

Independent of the current
 Proportional to the current

Independent of the Current

X-dir. given as: Constant
 Constant: 0

FileName
1

Y-dir. given as: Constant
 Constant: 0

FileName
1

Proportional to the Current

Proportionality factor in x- direction: 1 Min. value: 0
 Proportionality factor in y- direction: 1 Max. value: 0

Transport theory

For this application, the Engelund and Hansen formula is used for both bed load and suspended load. This formula is a total load formula, which means that factors need to be applied to determine what fraction of the total is bed load and what is suspended. If using e.g. the van Rijn (1984) formula, separate formulas apply for bed load and suspended load. In this application bed load is the dominant form of sediment transport, which is reflected in the values specified here (0.9 for bed load and 0.1 for suspended load). If unsure about this, set the factors to 1, perform an ST simulation, then compare the resulting bed load and suspended load output.

Transport Theory

	Bed load	Formula	Bed load factor
Component 1	<input checked="" type="checkbox"/>	Engelund & Hansen	0.900000

	Susp.load	Formula	Susp.load factor
Component 1	<input checked="" type="checkbox"/>	Engelund & Hansen	0.100000

Alluvial resistance

As well as bed level, bed resistance is updated. In this example, the equation for the Chezy number is

$$C = 30.85 h^{1/6} \quad (h \text{ is depth}) \quad (6.15)$$



This actually corresponds to a constant Manning number $M=30.85 \text{ m}^{1/3}/\text{s}$. Set the resistance coefficient to 30.65 and resistance power to 0.16667. Limits on the Chezy number between 5 and 100 are imposed.

Using the alluvial resistance model requires that the Chezy number is changed from constant to a dfs2 file (because it will vary in time and space), which is changed under the Resistance dialogue. Before entering the data file (dfs2) for the resistance, prepare flume_Chezy.dfs2 by copying the flume_bathy.dfs2 file and set all values in flume_Chezy.dfs2 to $18.7 \text{ (m}^{1/2}/\text{s)}$. During the simulation the Chezy numbers will be updated according to the prescribed alluvial resistance model, but with 50% relaxation in time, i.e. the newly calculated Chezy numbers are only weighted 50% compared to the existing Chezy numbers when updating the Chezy number map.

Morphological update

Specify zero layers (default). This means that the bed is an infinitely deep source of sediment with characteristics specified in the previous menu. It also means that the equilibrium layer thickness parameters (bottom right) are not used.

The morphological update parameters are upper limits that can be used for reducing instabilities. The maximum sediment Courant number means that the sediment transport time-step will be automatically adjusted so that the Courant number remains below this value. If zero, automatic time-step adjustment is not performed. The morphological update parameters are not needed for this simple model, and are all set to zero.

Morphological Update

Number of layers:

	Layer Name

Equilibrium Layer Thickness:

Factor on depth:

Minimum value:

Maximum value:

Morphological update

Update Bathymetry

Average inflow sedimentation

Average all boundary sedimentation



Boundary

No bed level change ($dz/dt = 0$) is specified at the boundaries.

Boundary		
Given as		
1: (0,1) - (0,3)	Bedlevel, Constant	
2: (139,1) - (139,3)	Bedlevel, Constant	
Boundary 1		
Component 1	Boundary 1	Boundary 2
	0.000000	0.000000



Note that this condition is only imposed at inflow boundaries, while no boundary conditions are necessary when there is outflow. Still it is necessary to prescribe the boundary conditions for all boundaries, as the GUI cannot in general determine before a simulation is carried out, whether a boundary has inflow or outflow. The condition means that the sediment transport from upstream has to be equal to what is transported in the model at the upstream boundary, which makes sense. The zero bed level change is a very popular boundary condition for alluvial rivers with one sediment fraction, while it cannot really be used for graded sediment and non-alluvial cases.

Results

Specify a result file that will contain bed load, suspended load, total load, bed level and bed level change. The title is "flume_st_morph"). A title can optionally be included in the file definition. Output of these parameters will give (apart from the answer!) an indication of how bed load and suspended load differ from each other, and how they combine to give the total.

6.3.9 Results

There are two output files from this simulation - the hydrodynamic (HD) results and the morphological (RV) results. To view these result files, use the Result Viewer. Figure 6.17 shows the RV model results at the last time-step (3600). Shading is bed level change and vectors are bed load.

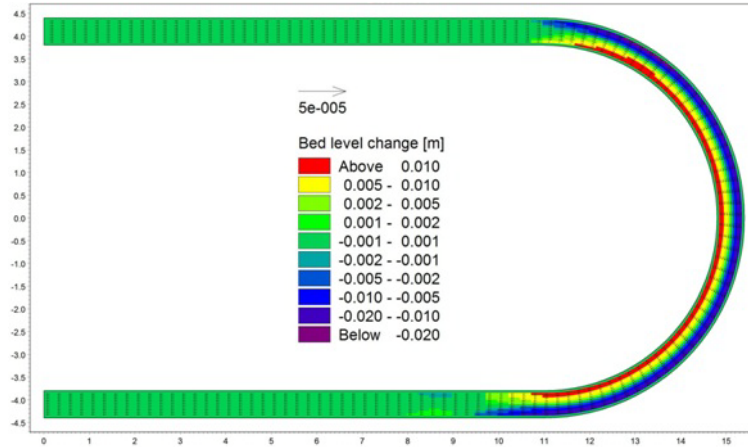

Figure 6.17 The Result Viewer model results 1 hour of morphological simulation

As shown in Figure 6.17, after 1 hour simulation the outer bend of the curved channel is getting deeper while the inner bend is getting shallower. To see more, repeat the simulation for a much longer period of time. Specify 86400 time-steps, which correspond to 24 hours. To ensure the result file is not too large, specify output every 900 time-steps (15 minutes). The bed level changes at the end of the simulation are as shown in Figure 6.18. To better see the variations in erosion and accretion, change the colour palette. Set the colours so that accretion varies from yellow to red, and erosion varies from light blue to dark blue. Finally, set the colour of zero bed level change to white:

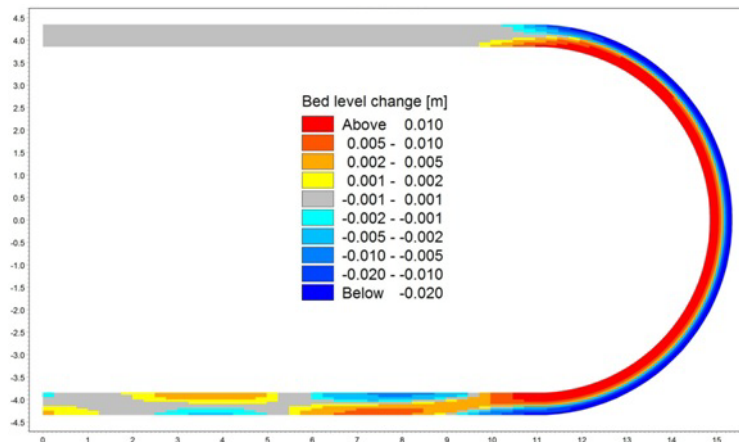

Figure 6.18 The areas of erosion and accretion in the model after 24 hours of simulation

This plot clearly shows the areas of erosion and accretion in the model. Morphological changes in the curved section of the flume have continued the trend shown in the 1 hour simulation, except the magnitude of bed level

change has increased. It is interesting to see deeper scouring at the entrance to the curved section (seen by blue shading around coordinates 13, 4). Note the patterns in the downstream straight section of the model. To look at the results further, take longitudinal profiles of model results at the inner, centre and outer lines. Using the plot composer or a spreadsheet, plot the three lines on the one graph, as shown in Figure 6.19. As the longitudinal plots will be used for further sensitivity analyses, the figures are shown at the end of this document. This will make comparisons between results easier.

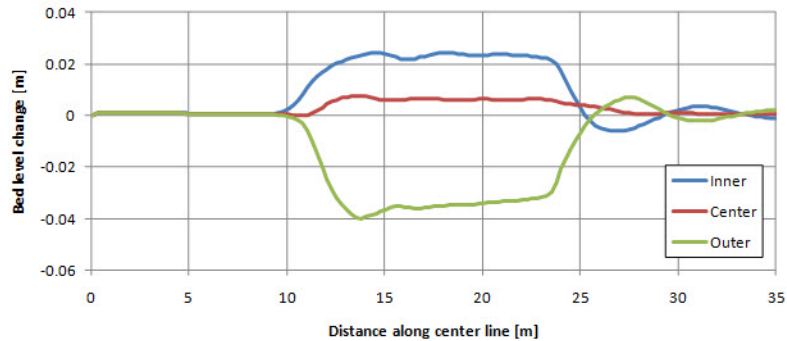

Figure 6.19 Longitudinal profile plot of bed level change, for 90% bed load and 10% suspended load

A note about dunes: The downstream behaviour of the bars is very sensitive to the transverse bed slope (this can be tested with different G values). The bed slope effect is calculated from the skin friction Shields parameter (θ'), which by default is the same as the total Shields parameter (θ). If using the Engelund (1966) form friction formula $\theta' = 0.06 + 0.4\theta^2$, the transverse slope effect becomes stronger due to the resulting smaller skin friction Shields parameter (due to $G(\theta')^{-a}$), and this will result in less instability downstream of the bend. The Engelund (1966) formula is by default not active, but can be made active with the option: `Engelund_1966 = true`. For the present application the best approach is not to use the Engelund (1966) formula because there are no dunes with this very fine material and these channel dimensions.

Some interesting points can be seen in Figure 6.19:

- At the beginning of the curved section (14 m from the upstream boundary) there is a very small bar on the outside of the curve. Immediately downstream there is an overshoot (at 17 m), where a scour hole exists. These are known characteristics in river bends, which are very sensitive to the distribution between bed load and suspended load.
- Downstream of the bend, patterns appear in the bed that appears to be oscillations. The reason for this is the bend introduces a disturbance in the flow and sediment transport, which produces point bars and pools downstream. If bank erosion was included, a meandering pattern would slowly develop with a characteristic meander wave length.



- The difference in bed level between the inner and outer banks is determined by the balance between bed slope effect (the G and a parameter) and helical flow intensity (the Helical Flow factor calibration parameter).

6.3.10 Further analysis

Helical flow

The last point made above suggests that the balance between bed slope and helical flow is important in morphological simulations. Investigate this by rerunning the simulation without helical flow. The longitudinal profiles at the inner, centre and outer lines are shown in Figure 6.20. As shown, the distribution of bed level in the bend is very different. This highlights the importance of including helical flow in a morphological simulation.

The helical flow is the driving mechanism in the formation of bend scour and point bars, and without this mechanism the only effect that is seen in the bed level is the effect of local accelerations at the entrance to and exit from the bend. It is observed that there is scour along the inner bank and deposition along the outer bank at the entrance to the bend, which is due to the concentration of the flow along the inner bank. A good principle to always keep in mind when working with morphology is that acceleration usually causes scour and vice versa.

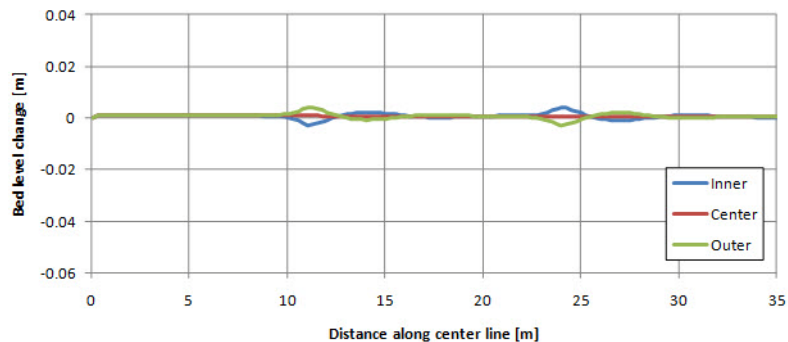

Figure 6.20 Longitudinal profile plot of bed level change, 90% bed load, no helical flow

Effect of bed load and suspended load

Rerun the simulation with all sediment transport occurring as bed load (zero suspended load). To do this, unclick the suspended load option and set the bed load calibration factor equal to 1. Remember to turn the helical flow back on (if you copied the input file from the zero helical flow simulation)! Also, run another simulation, this time with 80% suspended load and 20% bed load. Reproduce the longitudinal profile plot above for both simulations, shown in Figure 6.21 and Figure 6.22. It is noted that the case of 100% suspended

load is difficult to run with this model because in that case there is no way to balance the helical flow generated suspended load directed towards the inner bank.

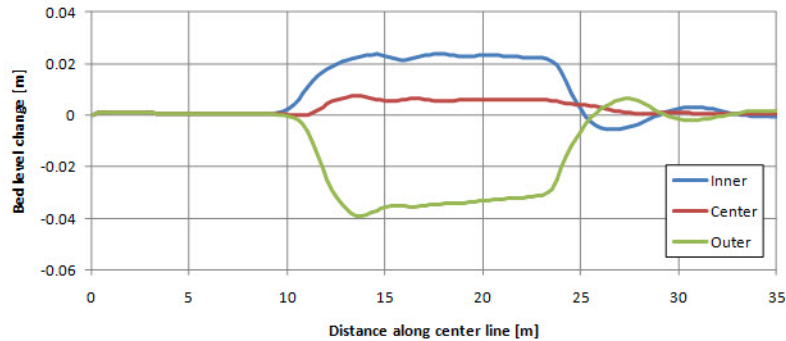

Figure 6.21 Longitudinal profile plot of bed level change, bed load only

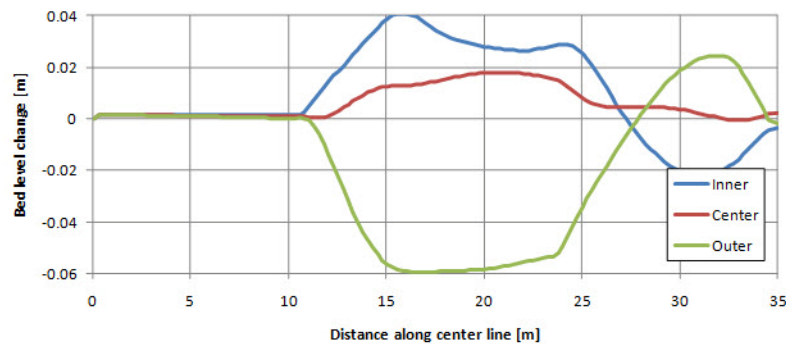

Figure 6.22 Longitudinal profile plot of bed level change, 80% suspended load

Bend scours and point bars are very sensitive to the distribution between bed load and suspended load because the bed slope, which is the only way to balance the helical flow, only acts on the bed load. The following observations can be made (also making comparisons to the simulation with combined bed and suspended loads):

- With bed load only, the overshoot and scour hole that develops at the start of the curve is less pronounced.
- With bed load only, oscillations downstream of the curve are damped.
- In comparison, the simulation with 80% suspended load oscillates.

These results suggest that the bed load is the dominant transport mechanism of sediment in this system, due to the bed slope effect. However, the suspended load component creates important disturbances in the system, which contributes to the formation of characteristic bed forms.



Effect of bed slope

The bed slope parameters G and a are associated with simulation of transverse bed slope. Deflection of the bed load direction $\tan(\nu)$ due to transverse bed slope is defined as $\tan(\nu) = G\theta^{(-a)} dz/dn$, where θ is the Shields parameter (non-dimensional bed shear stress) and dz/dn is the transverse bed slope. Until now the default values $G=0.66$ and $a=0.5$ based on theoretical analyses (laboratory conditions) have been used. To assess the effect of bed slope, perform a simulation with bed load only. This time, increase the value of G from 0.66 to 1.25 (the default value in MIKE 21C, corresponding to field conditions). The resulting profiles are shown in Figure 6.23.

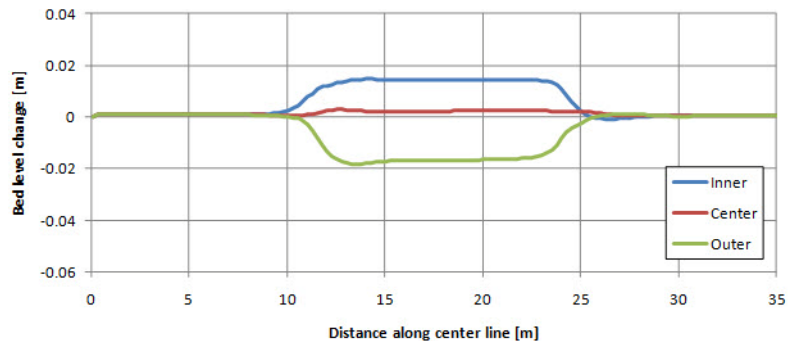

Figure 6.23 Longitudinal profile plot of bed level change, bed load only, $G = 1.25$

A high value of G reduces the transverse bed slope, resulting in less scouring along the outer bank. Oscillations downstream are also damped. These observations suggest that increasing the value of G will smooth the bathymetry.

6.4 Hydrodynamic Modelling of Retention Basin

6.4.1 Introduction

This tutorial describes the how to use various structure objects to simulate the flow over a river bank into a retention basin next to a river bend.

The curvilinear grid and simulation input files are supplied with the installation as it is assumed that the user is well acquainted with the workings of the MIKE 21C Grid Generator and MIKE 21C user interface.

The basis for the model setup and presentation of model results are given in the following sections.



6.4.2 Problem definition

This example has been chosen to describe the use of structures for the flow between a river and a retention basin during a period of flooding. The example is divided into three parts:

1. Discover the benefit of using a structure to simulate overflow
2. How to use composite structure to simulate function of retention basin
3. How to use time varying dike structure to model failure of river bank

6.4.3 Model bathymetry

The river section is 220 m long and 25 m wide. The river bed level is constant over the area at -4 m. The retention basin is 200 m long and 170 m wide with a uniform bed level at -2 m. Between the river and retention basin is a 5 m wide riverbank. The flow between the river and retention basin may take place along a 100 long section of the river bank, where the initial crest level is defined as +1 m. The location of the river bank section is defined by 20 (x,y) points as given in Table 6.1 and shown in Figure 6.24..

Table 6.1 Location of points for crest level definition of river bank

Point	X-coordinate	Y-coordinate
1	195.22	131.57
2	193.21	135.84
3	191.05	140.03
4	188.72	144.14
5	186.25	148.16
6	183.63	152.09
7	180.86	155.91
8	177.95	159.63
9	174.90	163.24
10	171.73	166.73
11	168.42	170.09
12	164.99	173.34
13	161.44	176.45
14	157.78	179.43
15	154.00	182.27
16	150.13	184.96
17	146.16	187.51
18	142.09	189.91



Table 6.1 Location of points for crest level definition of river bank

Point	X-coordinate	Y-coordinate
19	137.94	192.15
20	131.04	195.09

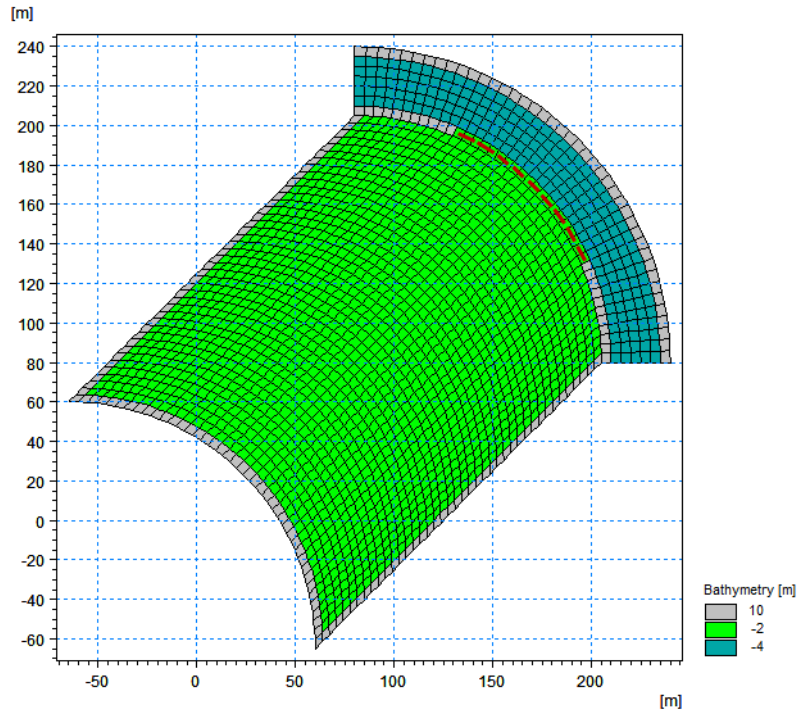

Figure 6.24 Bathymetry of retention basin
Location of river bank for overflow indicated by red stippled line

6.4.4 Hydrodynamic conditions

The natural flow in the river correspond to an overall water surface gradient of 0.0001, corresponding to a difference in water level between the upstream and downstream boundary of 0.02 m, resulting in uni-directional flow.

The water level in the river vary during time as shown in Figure 6.25. Initially the water level is -1m in the river and in the basin. Due to upstream flooding the water level in the river then increase linearly to about +2m during 3 hours whereafter the water level remains constant at the boundary during the next 6 hours. During the following 6 hours the water level in the river decrease linearly to level -2 m, whereafter the water level remains constant.

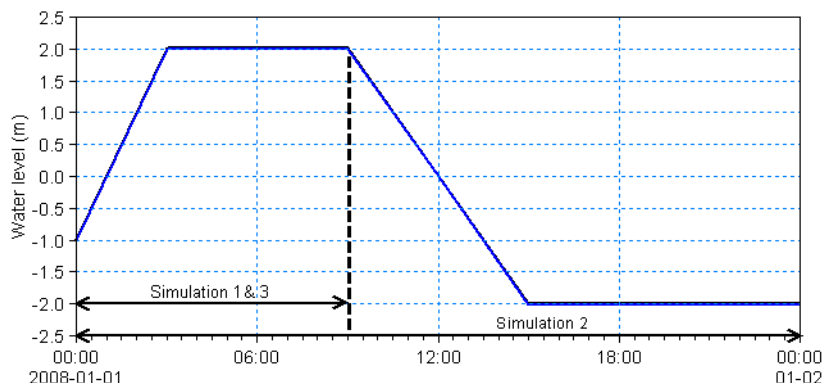

Figure 6.25 Water level in river section during simulations

Basic parameters

The overall conditions defining the problem are:

- The bathymetry is defined by a curvi-linear grid as shown in Figure 6.24
- The overall time step is 1 s
- The duration of the simulation is as indicated in Figure 6.25
- The length of the softstart interval (warm-up period) has been chosen to 180 seconds.
- The horizontal eddy viscosity type has been chosen as a flux based Smagorinsky formulation, applying a constant Smagorinsky coefficient of 1.0.
- The bed resistance type has been chosen to Manning number, applying a constant value of $32 \text{ m}^{1/3}/\text{s}$.
- The water level in the river is as shown in Figure 6.25. The initial water level in the river and in the retention basin is -1m.

6.4.5 Simulating overflow of river bank

The filling of the retention basin during the first 6 hours is simulated using three different approaches:

1. Defining the river bank by specifying the bathymetry level to +1 m.
2. Defining the river bank as a broad crested weir with crest level +1 m. The weir location is defined by the points in Table 6.1. The headloss factors



are defined by default values.

3. Defining the river bank as a dike with constant crest level +1 m.

Results

To compare the results of the three different approaches the water level in the basin is extracted and compared with the water level in the river. The results are shown in Figure 6.26.

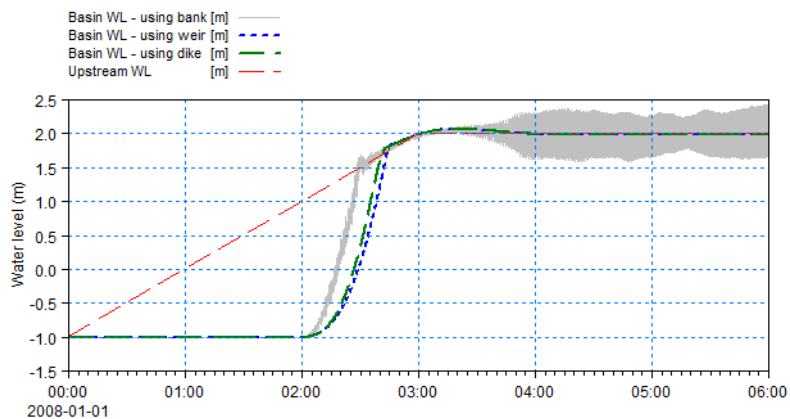

Figure 6.26 Water level at position (125m,120m) inside basin
 Thin red stippled line: upstream water level in river
 Grey solid line: water level using modified bathymetry
 Blue dotted line: water level using weir structure for river bank
 Green stippled line: water level using dike structure for river bank

Figure 6.26 shows that the model setup using the modified bathymetry gives far more disturbance in the model than the setups using a structure, and that the effect of modelling the river bank directly by the bathymetry level gives a faster filling of the basin than the by use of a structure. The latter effect is due to the fact that the structure computation includes contraction and expansion loss for the free overflow thus slowing the flow whereas the case with modified bathymetry does not include these energy losses explicitly.

Applying a dike with constant crest level may result in nearly the same discharge of water into the retention basin as when using a weir. The theory for flow over a dike corresponds to that for a weir with Formula 1.

6.4.6 Simulating emptying of retention basin

The filling and following emptying of the retention basin during a 24 hour period can be modelled using a composite structure:

- The river bank is defined as a broad crested weir with specifications as in the simulation above.
- Three identical culverts are placed along the same line section as the weir. The culverts are defined as closed, circular culverts with a diameter of 0.5 m and positioned at an invert level of -1.5 m both upstream and downstream. The headloss factors are defined by default values. The culverts have valves that only allows for positive flow (out into the river).

Results

To show the result the water level in the basin is extracted and compared with the water level in the river. The result is shown in Figure 6.27.

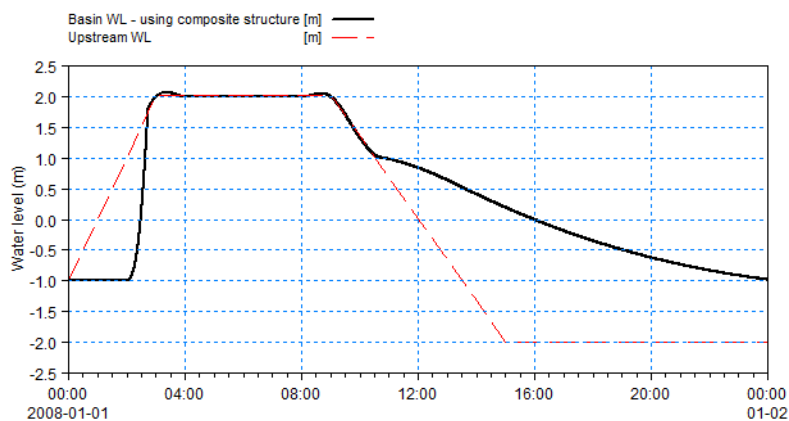

Figure 6.27 Water level at position (125m,120m) inside basin
 Red stippled line: upstream water level in river for reference
 Black solid line: water level inside basin

Figure 6.27 shows that the emptying of the retention basin through the three culverts are much slower than the time it takes to fill the basin. This is obviously because the free flow over the weir is critical and through a much larger cross-section whereas the flow out of the basin using the culverts are sub-critical with a much smaller cross-section.

6.4.7 Simulating failure of river bank

To model the failure of the river bank next to the retention basin the river bank is defined by a dike structure with a space- and time varying crest level.

- The riverbank is defined by the 20 (x,y) points defined in Table 6.1.
- The failure of the river bank start at 01:45 and ends at 02:00. Figure 6.28 illustrates the temporal variation of the crest level of the dike during the duration of the failure.

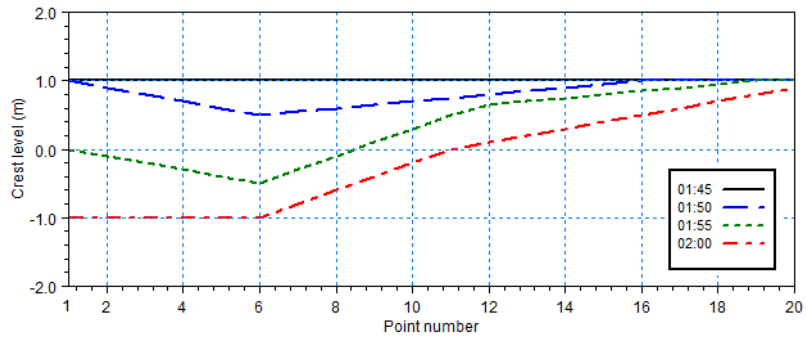

Figure 6.28 Crest level during failure occurrence

Results

To show the result the water level in the basin is extracted and compared with the water level in the river. The result is shown in Figure 6.29. The result for a dike with constant crest level is added for comparison.

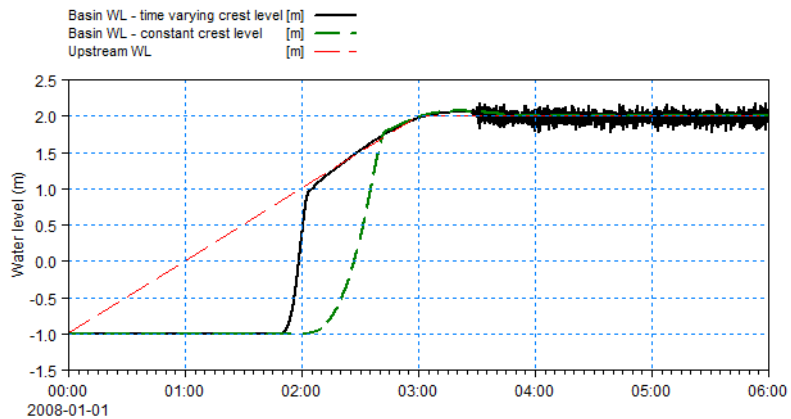

Figure 6.29 Water level at position (125m, 120m) inside basin
 Black solid line: water level for varying crest level
 Green stippled line: water level for constant crest level
 Red stippled line: upstream water level in river for reference

Figure 6.29 shows that the failure of the river bank enable the filling of the retention basin at an earlier time step, whereafter the surface elevation within the basin follows the surface elevation in the river. After some time the simulation becomes subject to numerical disturbance.



6.4.8 List of data and specification files

The following data files are supplied with MIKE 21C:

File name: Bat0_5m.dfs2

Description: Bathymetry grid, no river bank

File name: BatB_5m.dfs2

Description: Bathymetry grid, with river bank

File name: Bat0_5m_Coor.dfs2

Description: Geographical coordinates for 2D bathymetries

File name: WLBoundary.dfs0

Description: Water levels at river boundaries

File name: Sim1_Bank.m21c

Description: MIKE 21C specification file

File name: Sim1_Weir.m21c

Description: MIKE 21C specification file

File name: Sim1_Dike.m21c

Description: MIKE 21C specification file

File name: Sim2_Composite.m21c

Description: MIKE 21C specification file

File name: Sim3_Dike.m21c

Description: MIKE 21C specification file

File name: CrestLevelVariation.dfs1

Description: Varying crest level variation



7 MIKE 21C Utilities

7.1 Curvilinear Discharge Calculation

7.1.1 General description

With the Curvilinear Discharge Calculation tool you can calculate the discharge of water or sediment through the model area at selected cross-sections. The calculated discharges are obtained by integration along the specified line(s) of the instantaneous flux components perpendicular to the cell faces of interest and calculated for the specified time-steps.

The tool is activated from the MIKE Zero shell, see Figure 7.1.

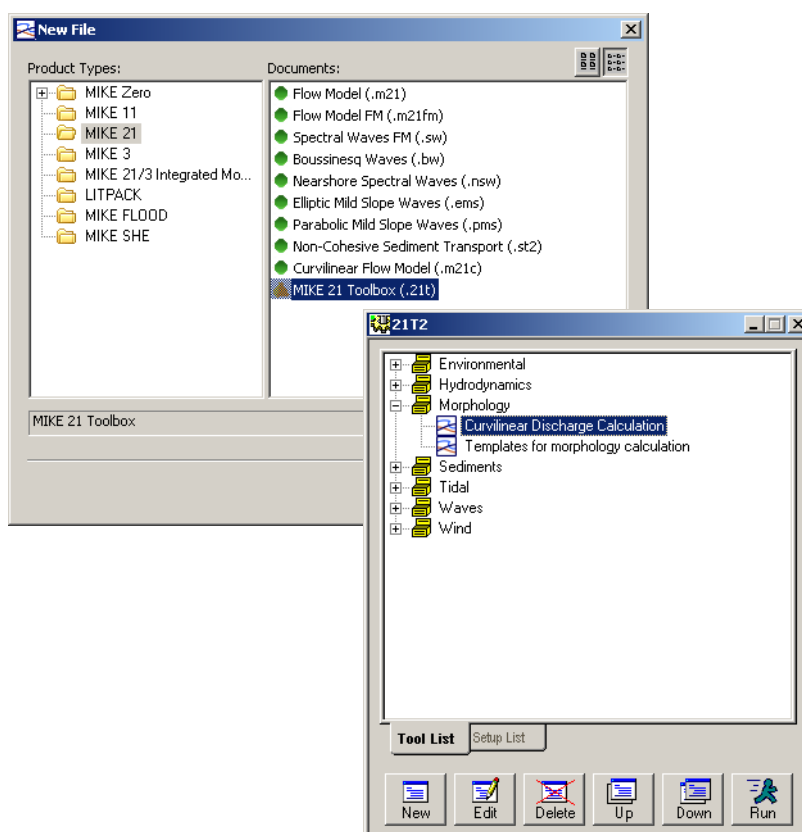

Figure 7.1 Creating new Curvelinear Discharge Calculation

The discharge is calculated for the specified time-steps.



7.1.2 Input data

Calculations are performed on the basis of data found in a user specified HD result file containing water depth and fluxes from a hydrodynamic simulation or an ST result file containing information about bed load, suspended load and/or total load.

The input consists of 2 files:

- A type 2 data file containing either HD simulation output (water level and fluxes) or river morphology simulation output (at least two items with sediment transport in both horizontal directions).
- A type 2 data file containing coordinates of the grid points in the curvilinear model. The file must contain two items: The x-coordinate and the y-coordinate.

7.1.3 Specifications

First you specify which data to use as described above.

The cross section defined as a straight line between a starting point and an end point is specified in grid coordinates (j,k). The specified cross sections have to be aligned with either the j-axis or the k-axis. The discharge can be calculated in up to 15 specified cross sections in one calculation.

If the input data file is not an HD simulation output file, the item number of the x-component of sediment transport must be specified. It is implicitly understood, that the y-component of sediment transport will be the subsequent item.

Discharge results are stored in a time series file and the name of the output file must be specified.

7.2 Result Viewer

The Result Viewer can display a number of result files of different format and from different modelling systems in the same plot provided that all result files are geo-referenced according to the same coordinate system.

The Result Viewer is activated from the MIKE Zero shell: File -> New -> File, select Result Viewer in the MIKE Zero Product type group.

7.2.1 Opening result files

New result file is opened using Projects -> Add Files to Project, press the icon for a new file (right side of menu), select file type: MIKE 21C Result File,



press browse button, select the results file, and press OK. Then select the corresponding grid file, and press OK.

Other file types include MIKE 11 result file, graduated time series file, image file, shape file, MIKE 21 result file, MIKE 3 result file, MIKE SHE result file, MIKE 11 Reservoir result file, etc.

The Overlay Manager dialogue is applied to determine in which order the result files are drawn. Each type of result file has a number of possible plots. For MIKE 21C, for instance, a 2D time varying grid overlay as well as a 2D time varying vector overlay can be drawn.

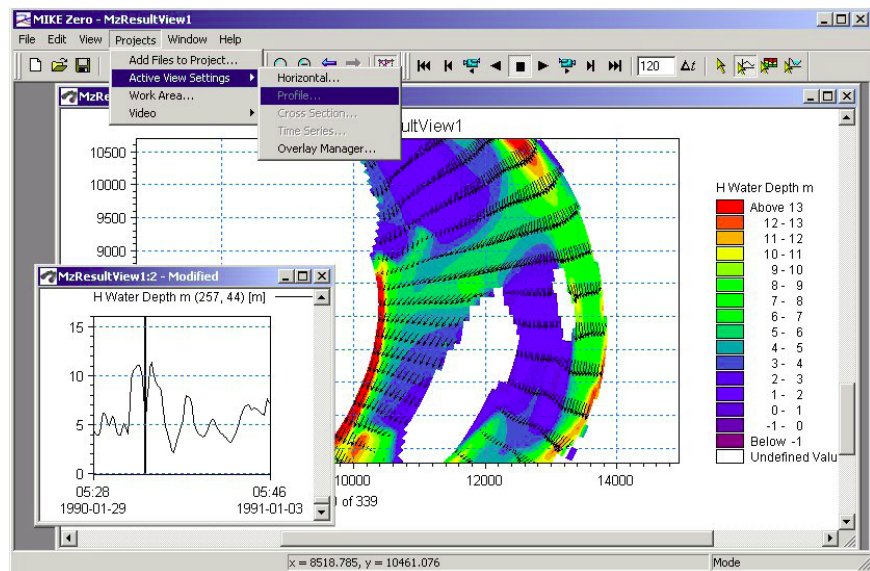

Figure 7.2 The Result Viewer dialogue

7.2.2 Formatting the view

After the result file is selected, it is displayed in the project window. The settings of the view of contours and/or vectors can be modified using Projects -> Active View Settings -> Horizontal. Separate settings are specified for grid overlay (contours) and vector overlay (arrows). The contour legend for grid overlays can be defined using the colour dialogue, where a colour palette file can be created, retrieved, edited, and saved for later use.

7.2.3 Changing the work area

The extent of the displayed working area can be changed either by zooming in and out or by specifying the working area using Projects -> Work Area. The default Work Area will always be the extent of modelling areas in the imported result files.



7.2.4 Creating animations

For morphological simulation, use of animations to visualise the results is important. The results can be animated on the screen by using the online control buttons for play, pause, play 1 step, rewind, go to end, etc. Video files can be created as well. Settings for the video file are specified in Projects -> Video.

7.2.5 Extracting time series

A time series of the value in a specific point can be displayed by pressing the time series button in the toolbar, and subsequently select the relevant grid point in the plan view.

Multiple grid points can be selected for the same view if the Ctrl button is pressed while selecting with mouse left-click. After selecting, the view is activated by double-click the mouse. The value, which is extracted, is the first grid overlay as specified in the Overlay Manager (see above).

7.2.6 Saving time series to files

Various operations with the view is activated by using the right-click on the mouse. For exporting the time series to a data file, use Right-click.. Export. To format the plot, use Right-Click -> Properties.

7.2.7 Import external data files into plots

For importing an existing time series file, use Right-click -> Properties -> Items. Use the Add-button to add a new data file.



INDEX



A	
Adaptation	56
Alluvial Resistance	38
B	
Bank Erosion	38
Bank lines	47
Bathymetry	13
Bed load factor	45
Bed slope effect	42
Boundary	51
Bridge	31
C	
Cold start	13
Component percentage	51
Connected source and sink pair	15
Culvert	25
Curvilinear grid	46
D	
Dike	28
Dispersion	44
Drying depth	15
E	
Eddy Viscosity	17
Equilibrium layer thickness	48
F	
Fall velocity	97
Flooding depth	15
G	
General time step	20
Graded sediment	75
Grain size	43
Grid	13
H	
HD Integration	78
Helical flow	38, 79
Hot start	13
I	
Integration Type	20
Isolated sink	15
Isolated source	15
L	
Layer thickness	51
Line series	18
M	
Map projection	100
Morphological Update	38
Mud, Debris and Oil	13
O	
Open boundaries	14
OPTION_PARAMETERS	79
P	
Planform	37
Porosity	98
Program detected	14
Q	
Quasi-steady HD solver	79
R	
Rating curve	18
Resistance	17
S	
Scaled Dynamic	20
Sediment density	98
Sediment formulae	98
Sediment Transport	38
Simulation start date	14
Sine series	18
Sink	18
Source	18
Suspended load factor	45
T	
Time series	18
Time step interval	14
Time step range	14
Transfer boundary tool	18
Transfer data	18
W	
Warm-up period	14
Weir	22